



URS PRODUCTS AND TESTING PRIVATE LIMITED

A-29, Sector-5, Noida-201301
T +91 (120) 4516264-65 F +91 (120) 4750296
E info@urs-labs.com W www.urs-labs.com
CIN NO U21014UP1987PTC008956



SUMMARY OF TEST REPORT

TEST REPORT NO:SC25SPI00628_1

DATED:17/04/2025

(Number of pages in test report: Page no. 1 to 35)

TEST FORMAT AS PER 16169: 2014/IEC 62116:2008

1. Name of Manufacturer:KSOLARE ENERGY PVT LTD,
2. Product:Solar GTI (Utility-Interconnected Photovoltaic Inverters)
Lead Model:KSY-6.2KW-1P-22A
Series Models:KSY-5.4KW-1P-22A, KSY-6KW-1P-22A, KSY-5KW-1P-22A, KSY-4.4KW-1P-22A, KSY-4KW-1P-22A, KSY-3.4KW-1P-22A, KSY-3KW-1P-22A, KSY-2KW-1P-22A, KSY-1KW-1P-22A
3. Model(s):
4. Model differences provided (if applicable):Yes
5. Model differences verified as per MNRE Guidelines for series formulation:Yes
6. Test Results:Refer below

S No.	TEST REQUIREMENT	CLAUSE	VERDICT
1.	Test for single or multi-phase inverter	6.0	Pass
2.	Islanding as it applies to PV systems(Informative)	Annex A	Pass
3.	Test for independent islanding detection device	Annex B	N/A





URS PRODUCTS AND TESTING PRIVATE LIMITED

A-29, Sector-5, Noida-201301
T +91 (120) 4516264-65 F +91 (120) 4750296
E info@urs-labs.com W www.urs-labs.com
CIN NO U21014UP1987PTC008956



General Information:

The conformity certificates of critical components are verified to ensure complete testing of apparatus under test and details regarding harmonized IEC standards (where IEC standards are not available) are also provided in the list of critical component.

CONCLUSION:

- 1.) Sample meets all relevant requirements of IS 16169: 2014/IEC 62116:2008 Yes
- 2.) Sample fails to meet the following test requirements: N/A
- 3) I hereby, undertake that the verdict stated in the test report for all the tests matches with the test results.

(Signature of Authorized person with Stamp)





URS PRODUCTS AND TESTING PRIVATE LIMITED

A-29, Sector-5, Noida-201301
T +91 (120) 4516264-65 F +91 (120) 4750296
E info@urs-labs.com W www.urs-labs.com
CIN NO U21014UP1987PTC008956



TC-6468

Report No- SC25SPI00628_1

IS 16169:2014 / IEC 62116 : 2008

Page 1 of 35

Dated : 17/04/2025

Manufacturer	KSOLARE ENERGY PVT LTD, SR NO.62, HISSA NO.3, MANGADEWADI, KATRAJ, PUNESATARA ROAD, PUNE, MAHARASHTRA, PIN 411046, MAHARASHTRA, 411046		
Test item:	Solar GTI (Utility-Interconnected Photovoltaic Inverters)		
Identification	Lead Model:KSY-6.2KW-1P-22A Series Model:KSY-5.4KW-1P-22A, KSY-6KW-1P-22A, KSY-5KW-1P-22A, KSY-4.4KW-1P-22A, KSY-4KW-1P-22A, KSY-3.4KW-1P-22A, KSY-3KW-1P-22A, KSY-2KW-1P-22A, KSY-1KW-1P-22A	Serial No.:	Refer page no. 4
Receipt No.:	URS/LAB/16169:2014/24-25/EFFC9895 / 25E833DN	Date of receipt:	12/03/2025
Testing laboratory and its address:	URS PRODUCTS AND TESTING PRIVATE LIMITED A-29, Sector-5, Noida-201301		
Test specification:	IS 16169:2014 / IEC 62116 : 2008 /		
Test Result:	The test item passed the test specification(s)		
Other Aspects:	Nil		
This test report relates to the test sample submitted and list of documents attached.			

Tested by:	Approved by / Authorized Signatory:	Issued by:
Shashi Prakash , Asst.Manager	PUJA KUMARI , Manager Technical	Paras Singh , Vice President (Technical)
Date: 17/04/2025	Date: 17/04/2025	Date: 17/04/2025



URS PRODUCTS AND TESTING PRIVATE LIMITED

A-29, Sector-5, Noida-201301
T +91 (120) 4516264-65 F +91 (120) 4750296
E info@urs-labs.com W www.urs-labs.com
CIN NO U21014UP1987PTC008956



Report No- SC25SPI00628_1 Page 2 of 35
Dated : 17/04/2025 IS 16169:2014 / IEC 62116 : 2008

TEST REPORT IS 16169:2014 / IEC 62116 : 2008 Test Procedure of Islanding Prevention Measures for Utility-Interconnected-Photovoltaic Inverters

Report Reference No. :	SC25SPI00628_1
Date of issue :	17/04/2025
Total number of pages	35
Testing Laboratory :	URS PRODUCTS AND TESTING PRIVATE LIMITED
Address	A-29, Sector-5, Noida-201301
Applicant's name :	KSOLARE ENERGY PVT LTD,
Address	SR NO.62, HISSA NO.3, MANGADEVADI, KATRAJ, PUNESATARA ROAD, PUNE, MAHARASHTRA, PIN 411046, MAHARASHTRA, 411046
Test specification:	
Standard	IS 16169:2014 / IEC 62116 : 2008
Test procedure	Compliance Report
Non-standard test method	N/A
Test Report Form No:	IS 16169/IEC 62116:2008_V1.0
Test Report Form(s) Originator	BIS
Master TRF	Dated: 05.04.2018
Test item description:	Solar GTI (Utility-Interconnected Photovoltaic Inverters)
Trade Mark	
Model/Type reference	Lead Model:KSY-6.2KW-1P-22A Series Model:KSY-5.4KW-1P-22A, KSY-6KW-1P-22A, KSY-5KW-1P-22A, KSY-4.4KW-1P-22A, KSY-4KW-1P-22A, KSY-3.4KW-1P-22A, KSY-3KW-1P-22A, KSY-2KW-1P-22A, KSY-1KW-1P-22A
Ratings	Refer marking label on page no. 4

Tested by:	Approved by / Authorized Signatory:	Issued by:
Shashi Prakash , Asst.Manager	PUJA KUMARI , Manager Technical	Paras Singh , Vice President (Technical)
Date: 17/04/2025	Date: 17/04/2025	Date: 17/04/2025



URS PRODUCTS AND TESTING PRIVATE LIMITED

A-29, Sector-5, Noida-201301
T +91 (120) 4516264-65 F +91 (120) 4750296
E info@urs-labs.com W www.urs-labs.com
CIN NO U21014UP1987PTC008956



TC-6468

Report No- SC25SPI00628_1

IS 16169:2014 / IEC 62116 : 2008

Page 3 of 35

Dated : 17/04/2025

Testing Procedure and testing location:

Testing Laboratory	URS PRODUCTS AND TESTING PRIVATE LIMITED	
Testing location/ address	A-29, Sector-5, Noida-201301	
Testing procedure:		
Tested by (name + signature):	Shashi Prakash , Asst.Manager	
Approved by (name + signature):	PUJA KUMARI , Manager Technical	

Summary of Testing

Tests performed (name of test and test clause): All applicable tests		Testing location: URS PRODUCTS AND TESTING PRIVATE LIMITED A-29, Sector 5, Noida-201301, India
Test for single or multi-phase inverter	6.0	
Documentation	7.0	
Unintentional Islanding		





URS PRODUCTS AND TESTING PRIVATE LIMITED

A-29, Sector-5, Noida-201301
T +91 (120) 4516264-65 F +91 (120) 4750296
E info@urs-labs.com W www.urs-labs.com
CIN NO U21014UP1987PTC008956



Report No- SC25SPI00628_1

IS 16169:2014 / IEC 62116 : 2008

Page 4 of 35

Dated : 17/04/2025

Copy of marking plate:

Copy of marking label:



KSY 6.2KW-1P-22A

Max. input voltage	550Vdc
MPPT voltage range	70-550V
Max. input current	22A+22A
Nominal DC input voltage	360V
Isc PV	26A
Protection Class	I
Vac/Fac Normal	230Vac/50Hz
Max. output current	26.95A
Rated AC output power	6200W
MFG Date	21/02/25
Power Factor	0.8Lead...1...0.8Lag
Operating Temp. range	-25 to +60 deg. C
Deg. of protection	IP 65



K SOLARE ENERGY PVT. LTD.
SR NO.82 HIS SA NO.3 MANGADEWADI,
KATRAJ, PUNE SATARA ROAD, PUNE -411048,
INDIA
www.ksolare.com

Marking Label of Lead Model

Sample Code	Serial no.
Sample - 1	KSY0225HS2262
Sample - 2	KSY0225HS2263





URS PRODUCTS AND TESTING PRIVATE LIMITED

A-29, Sector-5, Noida-201301
T +91 (120) 4516264-65 F +91 (120) 4750296
E info@urs-labs.com W www.urs-labs.com
CIN NO U21014UP1987PTC008956



Report No- SC25SPI00628_1

IS 16169:2014 / IEC 62116 : 2008

Page 5 of 35

Dated : 17/04/2025

 POWER LED	ON=Inverter is feeding power
	BLINK=DC is on, but the inverter is not feeding power
	OFF=DC is off
 FAULT LED	ON=Inverter is faulty
	OFF=No fault
 COM LED	BLINK=Communication device is connected to inverter
	OFF=No communication
⚠ WARNING	
	Danger to life due to high voltages ! Only qualified personnel can open and service the product !
	Disconnect the inverter from all the external power sources before service !
	Do not touch live parts until 5 minutes after disconnection 5mins from the sources !
	Hot surface ! May exceed 60°C !
	Check user manual before services !

Warning Statement





URS PRODUCTS AND TESTING PRIVATE LIMITED

A-29, Sector-5, Noida-201301
T +91 (120) 4516264-65 F +91 (120) 4750296
E info@urs-labs.com W www.urs-labs.com
CIN NO U21014UP1987PTC008956



Report No- SC25SPI00628_1

IS 16169:2014 / IEC 62116 : 2008

Page 6 of 35

Dated : 17/04/2025



KSY 5.4KW-1P-22A

Max. input voltage	550Vdc
MPPT voltage range	70-550V
Max. input current	22A+22A
Nominal DC input voltage	360V
Isc PV	26A
Protection Class	I
Vac/Fac Normal	230Vac/50Hz
Max. output current	23.47A
Rated AC output power	5400W
MFG Date	21/02/25
Power Factor	0.8Lead...1...0.8Lag
Operating Temp. range	-25 to +60 deg. C
Deg. of protection	IP 65

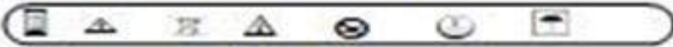

K SOLARE ENERGY PVT. LTD.
SR NO.82, HISSA NO.3, MANGADEWADI,
KATRAJ, PUNE SATARA ROAD, PUNE -411048,
INDIA
www.ksolare.com

Marking Label of Series Model





URS PRODUCTS AND TESTING PRIVATE LIMITED

A-29, Sector-5, Noida-201301
T +91 (120) 4516264-65 F +91 (120) 4750296
E info@urs-labs.com W www.urs-labs.com
CIN NO U21014UP1987PTC008956



Report No- SC25SPI00628_1

IS 16169:2014 / IEC 62116 : 2008

Page 7 of 35

Dated : 17/04/2025



KSY 6KW-1P-22A

Max. input voltage	550Vdc
MPPT voltage range	70-550V
Max. input current	22A
Nominal DC input voltage	360V
Isc PV	26A
Protection Class	I
Vac/Fac Normal	230Vac/50Hz
Max. output current	26.08A
Rated AC output power	6000W
MFG Date	21/02/25
Power Factor	0.8Lead...1...0.8Lag
Operating Temp. range	-25 to +60 deg. C
Deg. of protection	IP 65

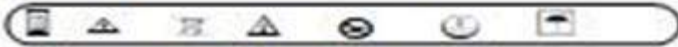

K SOLARE ENERGY PVT. LTD.
SR NO.82 HIS SA NO.3, MANGADEWADI,
KATRAJ, PUNE SATARA ROAD, PUNE -411048,
INDIA
www.ksolare.com

Marking Label of Series Model





URS PRODUCTS AND TESTING PRIVATE LIMITED

A-29, Sector-5, Noida-201301
T +91 (120) 4516264-65 F +91 (120) 4750296
E info@urs-labs.com W www.urs-labs.com
CIN NO U21014UP1987PTC008956



TC-6468

Report No- SC25SPI00628_1

IS 16169:2014 / IEC 62116 : 2008

Page 8 of 35

Dated : 17/04/2025



KSY 5KW-1P-22A

Max. input voltage	550Vdc
MPPT voltage range	70-550V
Max. input current	22A
Nominal DC input voltage	360V
Isc PV	26A
Protection Class	I
Vac/Fac Normal	230Vac/50 Hz
Max. output current	21.73A
Rated AC output power	5000W
MFG Date	21/02/25
Power Factor	0.8Lead...1...0.8Lag
Operating Temp. range	-25 to +60 deg. C
Deg. of protection	IP 65



SN: KSY0225HS2250



K SOLARE ENERGY PVT. LTD.
SR NO.62, HISSA NO.3, MANGADEWADI,
KATRAJ, PUNE SATARA ROAD, PUNE -411048,
INDIA
www.ksolare.com

Marking Label of Series Model





URS PRODUCTS AND TESTING PRIVATE LIMITED

A-29, Sector-5, Noida-201301
T +91 (120) 4516264-65 F +91 (120) 4750296
E info@urs-labs.com W www.urs-labs.com
CIN NO U21014UP1987PTC008956



Report No- SC25SPI00628_1

IS 16169:2014 / IEC 62116 : 2008

Page 9 of 35

Dated : 17/04/2025



KSY 4.4KW-1P-22A

Max. input voltage	550Vdc
MPPT voltage range	70-550V
Max. input current	22A
Nominal DC input voltage	360V
Isc PV	26A
Protection Class	I
Vac/Fac Normal	230Vac/50Hz
Max. output current	19.13A
Rated AC output power	4400W
MFG Date	21/02/25
Power Factor	0.8Lead...1...0.8Lag
Operating Temp. range	-25 to +60 deg. C
Deg. of protection	IP 65

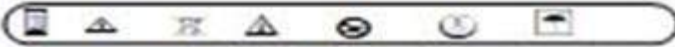

K SOLARE ENERGY PVT. LTD.
SR NO.62 HIS SA NO.3, MANGADEWADI,
KATRAJ, PUNE SATARA ROAD, PUNE -411048,
INDIA
www.ksolare.com

Marking Label of Series Model





URS PRODUCTS AND TESTING PRIVATE LIMITED

A-29, Sector-5, Noida-201301
T +91 (120) 4516264-65 F +91 (120) 4750296
E info@urs-labs.com W www.urs-labs.com
CIN NO U21014UP1987PTC008956



Report No- SC25SPI00628_1

IS 16169:2014 / IEC 62116 : 2008

Page 10 of 35

Dated : 17/04/2025



KSY 4KW-1P-22A

Max. input voltage	550Vdc
MPPT voltage range	70-550V
Max. input current	22A
Nominal DC input voltage	360V
Isc PV	26A
Protection Class	I
Vac/Fac Normal	230Vac/50Hz
Max. output current	18.2A
Rated AC output power	4000W
MFG Date	21/02/25
Power Factor	0.8Lead...1...0.8Lag
Operating Temp. range	-25 to +60 deg. C
Deg. of protection	IP 65



K SOLARE ENERGY PVT. LTD.
SR NO.82 HISSA NO.3, MANGADEWADI,
KATRAJ, PUNE SATARA ROAD, PUNE -411048,
INDIA
www.ksolare.com

Marking Label of Series Model





URS PRODUCTS AND TESTING PRIVATE LIMITED

A-29, Sector-5, Noida-201301
T +91 (120) 4516264-65 F +91 (120) 4750296
E info@urs-labs.com W www.urs-labs.com
CIN NO U21014UP1987PTC008956



TC-6468

Report No- SC25SPI00628_1

IS 16169:2014 / IEC 62116 : 2008

Page 11 of 35

Dated : 17/04/2025



KSY 3.4KW-1P-22A

Max. input voltage	550Vdc
MPPT voltage range	70-550V
Max. input current	22A
Nominal DC input voltage	360V
Isc PV	26A
Protection Class	I
Vac/Fac Normal	230Vac/50Hz
Max. output current	14.78A
Rated AC output power	3400W
MFG Date	21/02/25
Power Factor	0.8Lead...1...0.8Lag
Operating Temp. range	-25 to +60 deg. C
Deg. of protection	IP 65



K SOLARE ENERGY PVT. LTD.
SR NO.82, HIS SA NO.3, MANGADEWADI,
KATRAJ, PUNE SATARA ROAD, PUNE -411048,
INDIA
www.ksolare.com

Marking Label of Series Model





URS PRODUCTS AND TESTING PRIVATE LIMITED

A-29, Sector-5, Noida-201301
T +91 (120) 4516264-65 F +91 (120) 4750296
E info@urs-labs.com W www.urs-labs.com
CIN NO U21014UP1987PTC008956



TC-6468

Report No- SC25SPI00628_1

IS 16169:2014 / IEC 62116 : 2008

Page 12 of 35

Dated : 17/04/2025



KSY 3KW-1P-22A

Max. input voltage	550Vdc
MPPT voltage range	70-550V
Max. input current	22A
Nominal DC input voltage	360V
Isc PV	26A
Protection Class	I
Vac/Fac Normal	230Vac/50Hz
Max. output current	13.04A
Rated AC output power	3000W
MFG Date	21/02/25
Power Factor	0.8Lead...1...0.8Lag
Operating Temp. range	-25 to +60 deg. C
Deg. of protection	IP 65



K SOLARE ENERGY PVT. LTD.
SR NO.62, HIS SA NO.3, MANGADEWADI,
KATRAJ, PUNE SATARA ROAD, PUNE -411048,
INDIA
www.ksolare.com

Marking Label of Series Model





URS PRODUCTS AND TESTING PRIVATE LIMITED

A-29, Sector-5, Noida-201301
T +91 (120) 4516264-65 F +91 (120) 4750296
E info@urs-labs.com W www.urs-labs.com
CIN NO U21014UP1987PTC008956



TC-6468

Report No- SC25SPI00628_1

IS 16169:2014 / IEC 62116 : 2008

Page 13 of 35

Dated : 17/04/2025



KSY 2KW-1P-22A

Max. input voltage	550Vdc
MPPT voltage range	70-550V
Max. input current	22A
Nominal DC input voltage	360V
Isc PV	26A
Protection Class	I
Vac/Fac Normal	230Vac/50Hz
Max. output current	8.69A
Rated AC output power	2000W
MFG Date	21/02/25
Power Factor	0.8Lead...1...0.8Lag
Operating Temp. range	-25 to +60 deg. C
Deg. of protection	IP 65

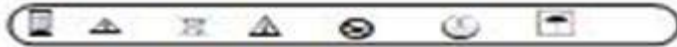

K SOLARE ENERGY PVT. LTD.
SR NO.82 HIS SA NO.3, MANGADEWADI,
KATRAJ, PUNE SATARA ROAD, PUNE -411048,
INDIA
www.ksolare.com

Marking Label of Series Model





URS PRODUCTS AND TESTING PRIVATE LIMITED

A-29, Sector-5, Noida-201301
T +91 (120) 4516264-65 F +91 (120) 4750296
E info@urs-labs.com W www.urs-labs.com
CIN NO U21014UP1987PTC008956



Report No- SC25SPI00628_1

IS 16169:2014 / IEC 62116 : 2008

Page 14 of 35

Dated : 17/04/2025



KSY IKW-1P-22A

Max. input voltage	550Vdc
MPPT voltage range	70-550V
Max. input current	22A
Nominal DC input voltage	360V
Isc PV	26A
Protection Class	I
Vac/Fac Normal	230Vac/50Hz
Max. output current	4.33A
Rated AC output power	1000W
MFG Date	21/02/25
Power Factor	0.8Lead...1...0.8Lag
Operating Temp. range	-25 to +60 deg. C
Deg. of protection	IP 65



K SOLARE ENERGY PVT. LTD.
SR NO.82, HISSA NO.3, MANGADEWADI,
KATRAJ, PUNE SATARA ROAD, PUNE -411048,
INDIA
www.ksolare.com

Marking Label of Series Model





URS PRODUCTS AND TESTING PRIVATE LIMITED

A-29, Sector-5, Noida-201301
T +91 (120) 4516264-65 F +91 (120) 4750296
E info@urs-labs.com W www.urs-labs.com
CIN NO U21014UP1987PTC008956



Report No- SC25SPI00628_1

IS 16169:2014 / IEC 62116 : 2008

Page 15 of 35

Dated : 17/04/2025

Possible test case verdicts:

- test case does not apply to the test object :N/A
 - test object does meet the requirement :P (Pass)
 - test object was not evaluated for the requirement :N/E
-
- test object does not meet the requirement :F (Fail)

Testing:

Date of receipt of test item: 12/03/2025
Date(s) of performance of tests: 13/03/2025 to 17/04/2025

GENERAL INFORMATION

Test item particulars: See below	
Accessories and detachable parts included in the evaluation	N/A
Options included	N/A
Abbreviations used in the report	See below
EUT – Equipment Under Test	MPPT – Maximum Power Point Tracking
Qf – Quality factor	W - Utility Real Power
Var – Utility Reactive Power	VDC – DC Voltage
VEUT – AC Voltage of EUT	tR – Run on time
IR – Resistive load current	IL – Inductive load current
IC – Capacitive load current	PAC – Utility Real Power
QAC – Utility Reactive Power	IAC – Utility Current
Possible test case verdicts: test case does not apply to the test object/td>	N/A
test object does meet the requirement	Pass (P)
test object does not meet the requirement	Fail (F)





URS PRODUCTS AND TESTING PRIVATE LIMITED

A-29, Sector-5, Noida-201301
T +91 (120) 4516264-65 F +91 (120) 4750296
E info@urs-labs.com W www.urs-labs.com
CIN NO U21014UP1987PTC008956



Report No- SC25SPI00628_1

IS 16169:2014 / IEC 62116 : 2008

Page 16 of 35

Dated : 17/04/2025

Manufacturer's Declaration per Standard:

Similarities between the models: Representative models and series models have following similarities

- 1) Same rated Input/ Output voltage, Input voltage
- 2) Same frequency
- 3) Number of Phases at output
- 4) Same PCB design and layout
- 5) Same Power Stage topology
- 6) Same Insulation Class
- 7) Same Control Algorithm/firmware
- 8) Same Cabinet Design
- 9) Class of construction

Differences between the models: Representative models and series models have following differences

Model name and electrical ratings (as per capacity).

General remarks:

The test results presented in this report relate only to the object tested.

This report shall not be reproduced, except in full, without the written approval of the Issuing testing laboratory.





URS PRODUCTS AND TESTING PRIVATE LIMITED

A-29, Sector-5, Noida-201301
 T +91 (120) 4516264-65 F +91 (120) 4750296
 E info@urs-labs.com W www.urs-labs.com
 CIN NO U21014UP1987PTC008956



Report No- SC25SPI00628_1

IS 16169:2014 / IEC 62116 : 2008

Page 17 of 35

Dated : 17/04/2025

General product information:

Product Electrical Ratings

Parameter	Value		Remarks
1) Rating			
a) Maximum output power	W	6200	---
b) DC voltage range	Vdc	140V - 300 (MPPT input voltage range)	---
c) DC current limits	Idc	22A+22A	---
d) AC voltage range	Vac	230	---
e) Frequency range	Hz	50	---
f) AC current limits	A	26.95A AC	---
g) Efficiency	%	Maximum efficiency (%): 98.0 Euro efficiency (%): 97.5	---
h) Voltage trip settings (magnitude and timing)	V	140V (Under voltage) for 100ms 300V (Over voltage) for 100ms	---
i) Frequency trip settings (magnitude and timing)	Hz	45Hz (Under frequency) for 100ms 55Hz (Over frequency) for 100ms	---
j) Other software settings	---	Provided in user manual	---
k) Firmware version	---	V1.0.0.00	---
2) Others	---	---	---
a) Displays	---	LED + LCD Display	---
b) Temperature range	°C	-25°C to +60°C	---
c) Humidity	%	0% to 100%	---
d)Weight	kg	10.1Kg. (approx.)	





URS PRODUCTS AND TESTING PRIVATE LIMITED

A-29, Sector-5, Noida-201301
 T +91 (120) 4516264-65 F +91 (120) 4750296
 E info@urs-labs.com W www.urs-labs.com
 CIN NO U21014UP1987PTC008956



Report No- SC25SPI00628_1

IS 16169:2014 / IEC 62116 : 2008

Page 18 of 35

Dated : 17/04/2025

Clause	Requirement + Test	Result - Remark	Verdict
4	Testing circuit	See below	P
	The testing circuit shown in Figure 1 is employed.	See below	P
	Similar circuits are used for three-phase output.	Single-phase output	N/A
	Parameters to be measured are shown in Table 1 and Figure 1. Parameters to be recorded in the test report are discussed in Clause 7.	Parameters measured according to clause 7 and recorded in the test report	P
5	Testing equipment	See below	P
5.1	Measuring instruments	See below	P
5.1.1	The waveform measurement/capture device is able to record the waveform from the beginning of the islanding test until the EUT ceases to energize the island.	For waveform measurement digital oscilloscope is used.	P
5.1.2	For multi-phase EUT, all phases are monitored	Single-phase EUT	N/A
5.1.3	A waveform monitor designed to detect and calculate the run-on time may be used.	Complies	P
5.1.4	For multi-phase EUT, the test and measurement equipment is recorded each phase current and each phase-to-neutral or phase-to-phase voltage, as appropriate, to determine fundamental frequency active and reactive power flow over the duration of the test	Single-phase EUT	N/A
5.1.5	A sampling rate of 10 kHz or higher is recommended. The minimum measurement accuracy is 1 % or less of rated EUT nominal output voltage and 1 % or less of rated EUT output current	Complies	P
5.1.6	Current, active power, and reactive power measurements through switch S1 used to determine the circuit balance conditions report the fundamental (50 Hz or 60 Hz) component.	Complies	P
5.2	DC power source	See below	P
5.2.1	General	See below	P
5.2.1 .1	A PV array or PV array simulator (preferred) may be used. If the EUT can operate in utilityinterconnected mode from a storage battery, a DC power source may be used in lieu of a battery as long as the DC power source is not the limiting device as far as the maximum EUT input current is concerned.	PV array simulator is used	P
5.2.1.2	The DC power source provides voltage and current necessary to meet the testing requirements described in Clause 6.	Complies	P
5.2.2	PV array simulator	See below	P
5.2.2.1	The tests are conducted at the input voltage defined in Table 2 below, and the current is limited to 1,5 times the	Complies	P





URS PRODUCTS AND TESTING PRIVATE LIMITED

A-29, Sector-5, Noida-201301
 T +91 (120) 4516264-65 F +91 (120) 4750296
 E info@urs-labs.com W www.urs-labs.com
 CIN NO U21014UP1987PTC008956



Report No- SC25SPI00628_1

IS 16169:2014 / IEC 62116 : 2008

Page 19 of 35

Dated : 17/04/2025

Clause	Requirement + Test	Result - Remark	Verdict
	rated photovoltaic input current, except when specified otherwise by the test requirements.		
5.2.2.2	A PV array simulator is recommended, however, any type of power source may be used if it does not influence the test results.	PV array simulator is used	P
5.2.3	Current and voltage limited DC power supply with series resistance	PV Array simulator is used	N/A
5.2.3.1	A DC power source used as the EUT input source is capable of EUT maximum input power (so as to achieve EUT maximum output power) at minimum and maximum EUT input operating voltage.	See above	N/A
5.2.3.2	The power source provides adjustable current and voltage limit, set to provide the desired short circuit current and open circuit voltage when combined with the series and shunt resistance described below.	See above	N/A
5.2.3.3	A series resistance (and, optionally, a shunt resistance) is selected to provide a fill factor within the range: Output power: Sufficient to provide maximum EUT output power and other levels specified by test conditions of table 5. Response speed: The response time of a simulator to a step in output voltage, due to a 5% load change, results in a settling of the output current to within 10% of its final value in less than 1ms. Stability: Excluding the variations caused by the EUT MPPT, simulator output power remains stable within 2 % of specified power level over the duration of the test: from the point where load balance is achieved until the island condition is cleared or the allowable run-on time is exceeded. Power factor: 0.25 to 0.8	See above	N/A
5.2.4	PV array	PV Array simulator is used	N/A
5.2.4.1	A PV array used as the EUT input source is capable of EUT maximum input power at minimum and maximum EUT input operating voltage.	See above	N/A
5.2.4.2	Testing is limited to times when the irradiance varies by no more than 2 % over the duration of the test as measured by a silicon-type pyranometer or reference device. It may be necessary to adjust the array configuration to achieve the input voltage and power levels prescribed in 6.1.	See above	N/A
5.3	AC power source	See below	
5.3.1	The utility grid or other AC power source may be used as long as it meets the conditions specified in Table 4.	Meets the conditions specified in Table 4.	P
5.4	AC loads	See below	P

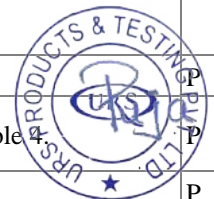



URS PRODUCTS AND TESTING PRIVATE LIMITED

A-29, Sector-5, Noida-201301
 T +91 (120) 4516264-65 F +91 (120) 4750296
 E info@urs-labs.com W www.urs-labs.com
 CIN NO U21014UP1987PTC008956



Report No- SC25SPI00628_1

IS 16169:2014 / IEC 62116 : 2008

Page 20 of 35

Dated : 17/04/2025

Clause	Requirement + Test	Result - Remark	Verdict
5.4.1	On the AC side of the EUT, variable resistance, capacitance, and inductance are connected in parallel as loads between the EUT and the AC power source. Other sources of load, such as electronic loads, may be used if it can be shown that the source does not cause results that are different than would be obtained with passive resistors, inductors, and capacitors.	Variable RLC (AC) load used	P
5.4.2	All AC loads are rated for and adjustable to all test conditions. The equations for Qf are based upon an ideal parallel RLC circuit. For this reason, noninductive resistors, low loss (high Qf) inductors, and capacitors with low effective series resistance and effective series inductance are utilized in the test circuit. Iron core inductors, if used, are not exceed a current THD of 2 % when operated at nominal voltage. Load components are conservatively rated for the voltage and power levels expected. Resistor power ratings are chosen so as to minimize thermally-induced drift in esistance values during the course of the test	Meeting the requirement	P
5.4.3	Active and reactive power is calculated (using the measurements provided in Table 1) in each of the R, L and C legs of the load so that these parasitic parameters (and parasitics introduced by variacs or autotransformers) are properly accounted for when calculating Qf	Complies	P
6	Test for single or multi-phase inverter	See below	P
6.1	Test procedure	See below	P
	The test uses an RLC load, resonant at the EUT nominal frequency (50 Hz or 60 Hz) and matched to the EUT output power.	Variable RLC (AC) load used`	P
	For multi-phase EUT, the load is balanced across all phases and the switch S1 as in Figure 1 opens all phases	Single-phase EUT	N/A
	This test is performed with the EUT conditions as in Table 5, where power and voltage values are given as a percent of EUT full output rating.	See below	P
	a). Determine EUT test output power	See appended table 6.1	P
	b) Adjusting the DC input source	See appended table 6.1	P
	c) Turn off the EUT and open S1	See appended table 6.1	P
	d) Adjust the RLC circuit to have $Q_f = 1.0 \pm 0.05$	See appended table 6.1	P
	e). Connect the RLC load configured in step d) to the EUT by closing S2	See appended table 6.1	P
	f).. Open the utility-disconnect switch S1 to initiate the test, Run-on time is recorded.	See appended table 6.1	P

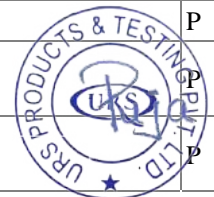



URS PRODUCTS AND TESTING PRIVATE LIMITED

A-29, Sector-5, Noida-201301
 T +91 (120) 4516264-65 F +91 (120) 4750296
 E info@urs-labs.com W www.urs-labs.com
 CIN NO U21014UP1987PTC008956



Report No- SC25SPI00628_1

IS 16169:2014 / IEC 62116 : 2008

Page 21 of 35

Dated : 17/04/2025

Clause	Requirement + Test	Result - Remark	Verdict
	g). For test condition A, adjust the real load and only one of the reactive load components to each of the load imbalance conditions shown in the shaded portion of table 6. If any of the recorded run-on times are longer than the one recorded for the rated balance condition, then the non-shaded parameter combinations also require testing.	See appended table 6.1	P
	h) For test condition B and C, adjust the only one reactive load components by approximately 1,0% per test, within a total range of 95% to 105% of the operating point. If run-on times are still increasing at the 95% or 105% points, additional 1% increments have to be taken until run-on times begin decreasing.	See appended table 6.1	P
6.2	Pass/fail criteria	See below	P
	An EUT is considered to comply with the requirements for islanding protection when each case of recorded run-on time is less than 2 s or meets the requirements of local codes.	See appended table 6.1	P
7	Documentation	See below	P
	At a minimum, the following information is recorded and maintained in the test report.	See below	P
	a) Specifications of EUT. Table 8 provides an example of the type of information that is provided.	Complies	P
	b) Measurement results. Table 9 provides an example of the type of information that is provided. Actual measured values is to be recorded.	See appended table 6.1	P
	c) Block diagram of test circuit	See last page no. of test report	P
	d) Specifications of the test and measurement equipment. Table 10 provides an example of the type of information that is provided	Complies	P
	e) Any test configuration or procedure details such as methods of achieving specified load and EUT output conditions	Complies	P
	f) Any additional information required by the testing laboratory's accreditation.	Nil	N/A
	g) Specify the evaluation criterion from clause 6.2 that was utilized to determine if the product passed or failed the test.	Comply with the criteria	P
Annex A	Islanding as it applies to PV systems(Informative)	Complies	
A.1	General	See above Annex A	
A.2	Impact of distortion on islanding	See above Annex A	





URS PRODUCTS AND TESTING PRIVATE LIMITED

A-29, Sector-5, Noida-201301
T +91 (120) 4516264-65 F +91 (120) 4750296
E info@urs-labs.com W www.urs-labs.com
CIN NO U21014UP1987PTC008956



Report No- SC25SPI00628_1

IS 16169:2014 / IEC 62116 : 2008

Page 22 of 35

Dated : 17/04/2025

Clause	Requirement + Test	Result - Remark	Verdict
Annex B	Test for independent islanding detection device (relay) (Informative)	No such application	N/A
B.1	Introduction	See above	N/A
B.2	Testing circuit	See above	N/A
B.3	Testing equipment	See above	N/A
B.4	Testing procedure	See above	N/A
B.5	Documentation	See above	N/A





URS PRODUCTS AND TESTING PRIVATE LIMITED

A-29, Sector-5, Noida-201301
 T +91 (120) 4516264-65 F +91 (120) 4750296
 E info@urs-labs.com W www.urs-labs.com
 CIN NO U21014UP1987PTC008956



Report No- SC25SPI00628_1

IS 16169:2014 / IEC 62116 : 2008

Page 23 of 35

Dated : 17/04/2025

Clause	Requirement + Test	Result - Remark	Verdict
--------	--------------------	-----------------	---------

6.1 Table: Tested condition and run-on time												
Sr. No.	PEUT (% of EUT rating)	Reactive load (% of QL)	PAC (% of nominal)	QAC (% of nominal)	Run on time (ms)	PEUT (W)	Pr (Resistive) (W)	PI (Inductive) Var	Pc (Capacitive) Var	Actual Qf	VDC	Remarks
1	100	100	0	0	539	6200	6200	6148	6088	0.987	410	Test B at BL
2	66	66	0	0	507	4092	4092	4102	4114	1.004	290	Test B at BL
3	33	33	0	0	407	2046	2046	2061	2025	0.998	170	Test B at BL
4	100	100	-5	-5	280	6200	6510	6148	6392	0.963	410	Test A at IB
5	100	100	-5	0	210	6200	6510	6148	6392	0.963	410	Test A at IB
6	100	100	-5	5	186	6200	6510	6148	5784	0.916	410	Test A at IB
7	100	100	0	-5	253	6200	6200	6148	6392	1.011	410	Test A at IB
8	100	100	0	5	185	6200	6200	6148	5784	0.962	410	Test A at IB
9	100	100	5	-5	241	6200	5890	6148	6392	1.064	410	Test A at IB
10	100	100	5	0	112	6200	5890	6148	6392	1.064	410	Test A at IB
11	100	100	5	5	352	6200	5890	6148	5784	1.012	410	Test A at IB
12	100	100	-10	10	110	6200	6820	6148	5479	0.851	410	Test A at IB
13	100	100	-5	10	213	6200	6510	6148	5479	0.892	410	Test A at IB
14	100	100	0	10	152	6200	6200	6148	5479	0.936	410	Test A at IB
15	100	100	10	10	142	6200	5580	6148	5479	1.040	410	Test A at IB
16	100	100	10	5	264	6200	5580	6148	5784	1.069	410	Test A at IB
17	100	100	10	0	243	6200	5580	6148	6088	1.096	410	Test A at IB
18	100	100	10	-5	245	6200	5580	6148	6392	1.123	410	Test A at IB
19	100	100	10	-10	246	6200	5580	6148	6697	1.150	410	Test A at IB
20	100	100	5	-10	241	6200	5890	6148	6697	1.089	410	Test A at IB
21	100	100	0	-10	256	6200	6200	6148	6697	1.035	410	Test A at IB
22	100	100	-5	-10	263	6200	6510	6148	6697	0.986	410	Test A at IB
23	100	100	-10	-10	452	6200	6820	6148	6697	0.941	410	Test A at IB
24	100	100	-10	-5	365	6200	6820	6148	6392	0.919	410	Test A at IB
25	100	100	-10	0	125	6200	6820	6148	6088	0.897	410	Test A at IB
26	100	100	-10	5	196	6200	6820	6148	5784	0.874	410	Test A at IB
27	66	66	0	-5	375	4092	4092	4102	4320	1.029	290	Test A at IB
28	66	66	0	-4	254	4092	4092	4102	4279	1.024	290	Test A at IB
29	66	66	0	-3	365	4092	4092	4102	4237	1.019	290	Test A at IB
30	66	66	0	-2	254	4092	4092	4102	4196	1.014	290	Test A at IB
31	66	66	0	-1	366	4092	4092	4102	4155	1.009	290	Test A at IB
32	66	66	0	1	289	4092	4092	4102	4073	0.999	290	Test A at IB
33	66	66	0	2	209	4092	4092	4102	4032	0.994	290	Test A at IB
34	66	66	0	3	246	4092	4092	4102	3991	0.989	290	Test A at IB
35	66	66	0	4	210	4092	4092	4102	3949	0.984	290	Test A at IB
36	66	66	0	5	224	4092	4092	4102	3908	0.978	290	Test A at IB
37	33	33	0	-5	354	2046	2046	2061	2126	1.023	170	Test A at IB
38	33	33	0	-4	268	2046	2046	2061	2106	1.018	170	Test A at IB



URS PRODUCTS AND TESTING PRIVATE LIMITED

A-29, Sector-5, Noida-201301
T +91 (120) 4516264-65 F +91 (120) 4750296
E info@urs-labs.com W www.urs-labs.com
CIN NO U21014UP1987PTC008956



TC-6468

Report No- SC25SPI00628_1

IS 16169:2014 / IEC 62116 : 2008

Page 24 of 35

Dated : 17/04/2025

Clause	Requirement + Test						Result - Remark						Verdict
39	33	33	0	-3	412	2046	2046	2061	2086	1.013	170	Test A at IB	
40	33	33	0	-2	326	2046	2046	2061	2066	1.008	170	Test A at IB	
41	33	33	0	-1	283	2046	2046	2061	2045	1.003	170	Test A at IB	
42	33	33	0	1	345	2046	2046	2061	2005	0.993	170	Test A at IB	
43	33	33	0	2	218	2046	2046	2061	1985	0.988	170	Test A at IB	
44	33	33	0	3	210	2046	2046	2061	1964	0.983	170	Test A at IB	
45	33	33	0	4	115	2046	2046	2061	1944	0.978	170	Test A at IB	
46	33	33	0	5	198	2046	2046	2061	1924	0.973	170	Test A at IB	

a PEUT: EUT output power.

b PAC: Active power flow at S1 in figure 1. Positive means power from EUT to utility. Nominal is the 0% test condition value.

C QAC: Reactive power flow at S1 in figure 1. Positive means power from EUT to utility. Nominal is the 0% test condition value.

D BL: balance condition, IB: imbalance condition.





URS PRODUCTS AND TESTING PRIVATE LIMITED

A-29, Sector-5, Noida-201301
T +91 (120) 4516264-65 F +91 (120) 4750296
E info@urs-labs.com W www.urs-labs.com
CIN NO U21014UP1987PTC008956



Report No- SC25SPI00628_1

IS 16169:2014 / IEC 62116 : 2008

Page 25 of 35

Dated : 17/04/2025

Clause	Requirement + Test	Result - Remark	Verdict
--------	--------------------	-----------------	---------

Appendix A Photograph





URS PRODUCTS AND TESTING PRIVATE LIMITED

A-29, Sector-5, Noida-201301
T +91 (120) 4516264-65 F +91 (120) 4750296
E info@urs-labs.com W www.urs-labs.com
CIN NO U21014UP1987PTC008956



Report No- SC25SPI00628_1

IS 16169:2014 / IEC 62116 : 2008

Page 26 of 35

Dated : 17/04/2025

Clause	Requirement + Test	Result - Remark	Verdict
--------	--------------------	-----------------	---------



Rear View



Port View





URS PRODUCTS AND TESTING PRIVATE LIMITED

A-29, Sector-5, Noida-201301
T +91 (120) 4516264-65 F +91 (120) 4750296
E info@urs-labs.com W www.urs-labs.com
CIN NO U21014UP1987PTC008956



TC-6468

Report No- SC25SPI00628_1

IS 16169:2014 / IEC 62116 : 2008

Page 27 of 35

Dated : 17/04/2025

Clause	Requirement + Test	Result - Remark	Verdict
--------	--------------------	-----------------	---------



Internal View



PCB Front View





URS PRODUCTS AND TESTING PRIVATE LIMITED

A-29, Sector-5, Noida-201301
T +91 (120) 4516264-65 F +91 (120) 4750296
E info@urs-labs.com W www.urs-labs.com
CIN NO U21014UP1987PTC008956



TC-6468

Report No- SC25SPI00628_1

IS 16169:2014 / IEC 62116 : 2008

Page 28 of 35

Dated : 17/04/2025

Clause	Requirement + Test	Result - Remark	Verdict
--------	--------------------	-----------------	---------

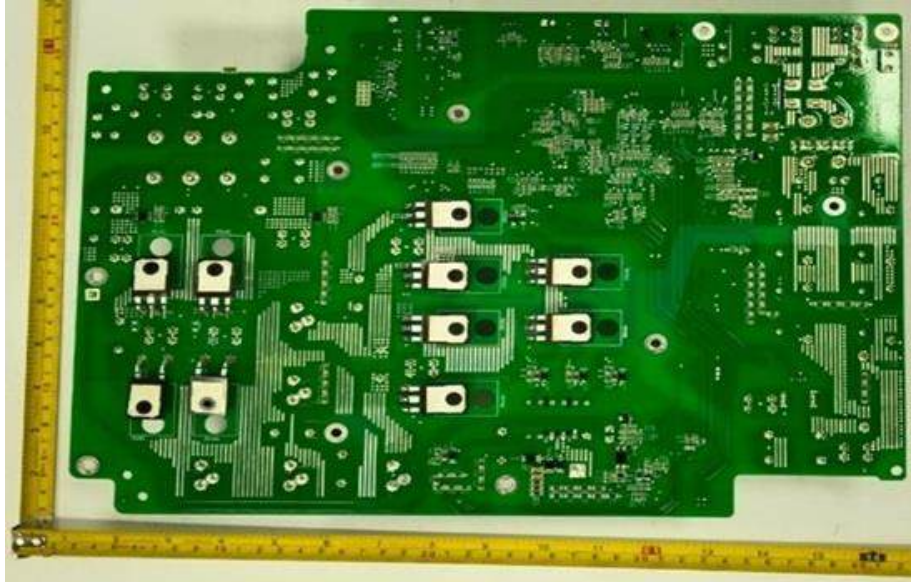

PCB Rear View





URS PRODUCTS AND TESTING PRIVATE LIMITED

A-29, Sector-5, Noida-201301
T +91 (120) 4516264-65 F +91 (120) 4750296
E info@urs-labs.com W www.urs-labs.com
CIN NO U21014UP1987PTC008956



TC-6468

Report No- SC25SPI00628_1

IS 16169:2014 / IEC 62116 : 2008

Page 29 of 35

Dated : 17/04/2025

Clause	Requirement + Test	Result - Remark	Verdict
--------	--------------------	-----------------	---------

WAVEFORMS

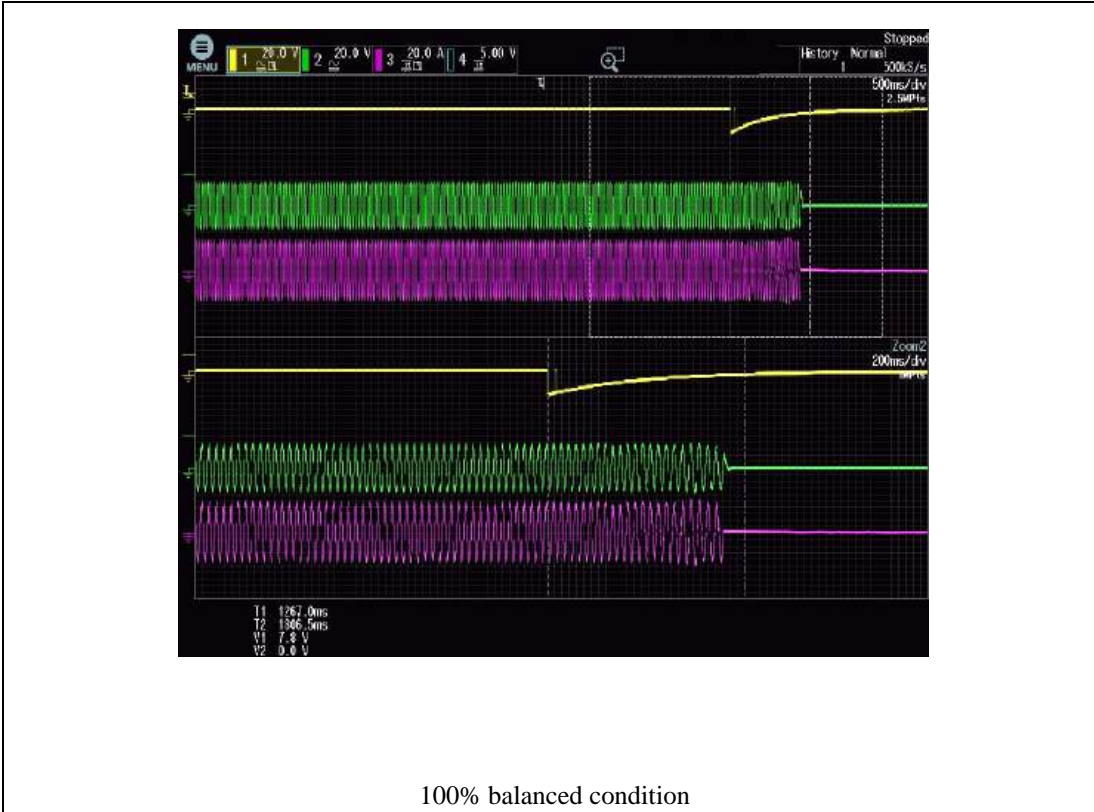



URS PRODUCTS AND TESTING PRIVATE LIMITED

A-29, Sector-5, Noida-201301
T +91 (120) 4516264-65 F +91 (120) 4750296
E info@urs-labs.com W www.urs-labs.com
CIN NO U21014UP1987PTC008956



Report No- SC25SPI00628_1

IS 16169:2014 / IEC 62116 : 2008

Page 30 of 35

Dated : 17/04/2025

Clause	Requirement + Test	Result - Remark	Verdict
--------	--------------------	-----------------	---------

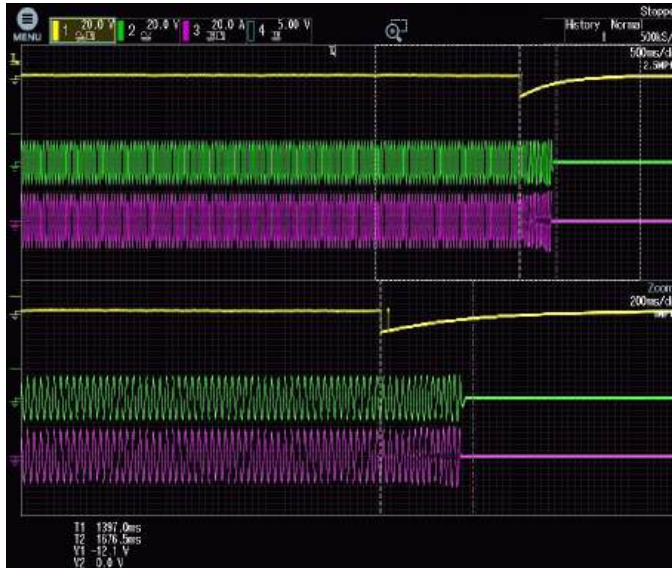

100% Unbalanced condition





URS PRODUCTS AND TESTING PRIVATE LIMITED

A-29, Sector-5, Noida-201301
T +91 (120) 4516264-65 F +91 (120) 4750296
E info@urs-labs.com W www.urs-labs.com
CIN NO U21014UP1987PTC008956



TC-6468

Report No- SC25SPI00628_1

IS 16169:2014 / IEC 62116 : 2008

Page 31 of 35

Dated : 17/04/2025

Clause	Requirement + Test	Result - Remark	Verdict
--------	--------------------	-----------------	---------

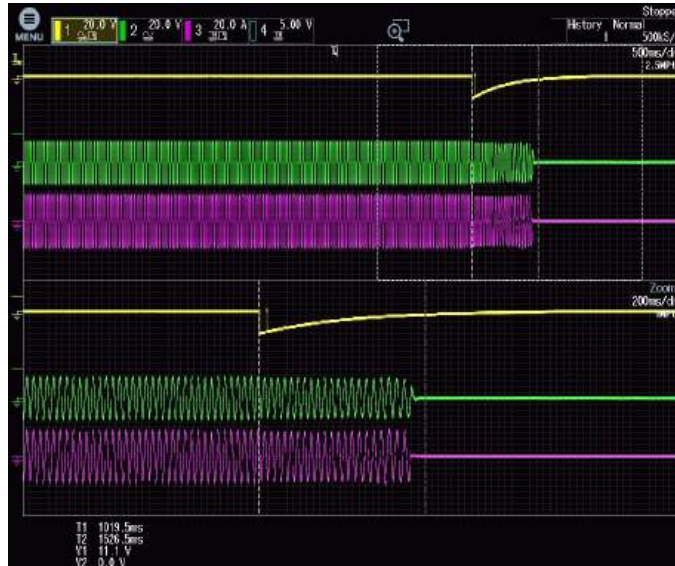

66% balanced condition





URS PRODUCTS AND TESTING PRIVATE LIMITED

A-29, Sector-5, Noida-201301
T +91 (120) 4516264-65 F +91 (120) 4750296
E info@urs-labs.com W www.urs-labs.com
CIN NO U21014UP1987PTC008956



Report No- SC25SPI00628_1

IS 16169:2014 / IEC 62116 : 2008

Page 32 of 35

Dated : 17/04/2025

Clause	Requirement + Test	Result - Remark	Verdict
--------	--------------------	-----------------	---------

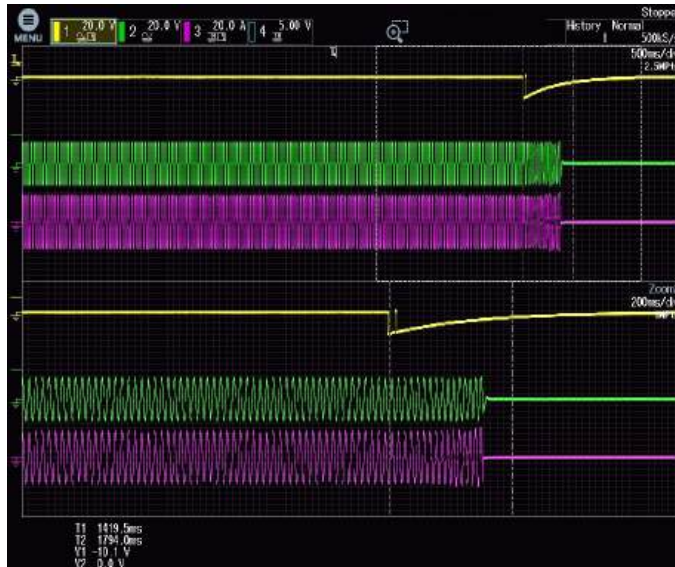

66% Unbalanced condition





URS PRODUCTS AND TESTING PRIVATE LIMITED

A-29, Sector-5, Noida-201301
T +91 (120) 4516264-65 F +91 (120) 4750296
E info@urs-labs.com W www.urs-labs.com
CIN NO U21014UP1987PTC008956



Report No- SC25SPI00628_1

IS 16169:2014 / IEC 62116 : 2008

Page 33 of 35

Dated : 17/04/2025

Clause	Requirement + Test	Result - Remark	Verdict
--------	--------------------	-----------------	---------

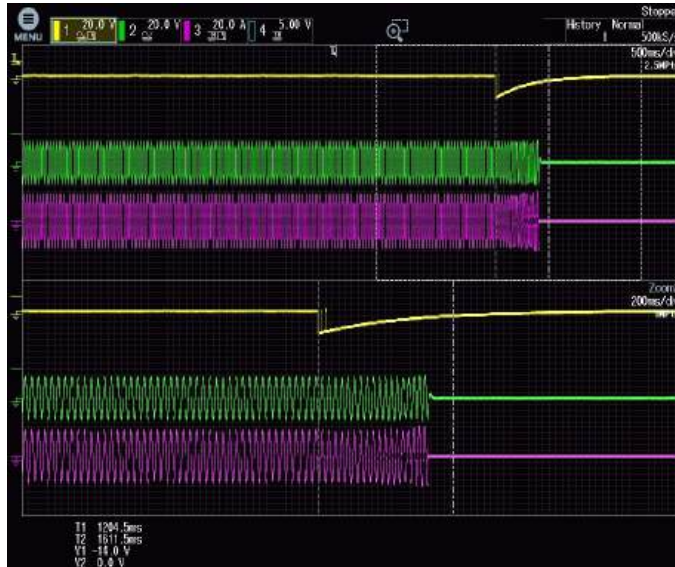

33% balanced condition





URS PRODUCTS AND TESTING PRIVATE LIMITED

A-29, Sector-5, Noida-201301
T +91 (120) 4516264-65 F +91 (120) 4750296
E info@urs-labs.com W www.urs-labs.com
CIN NO U21014UP1987PTC008956



Report No- SC25SPI00628_1

IS 16169:2014 / IEC 62116 : 2008

Page 34 of 35

Dated : 17/04/2025

Clause	Requirement + Test	Result - Remark	Verdict
--------	--------------------	-----------------	---------

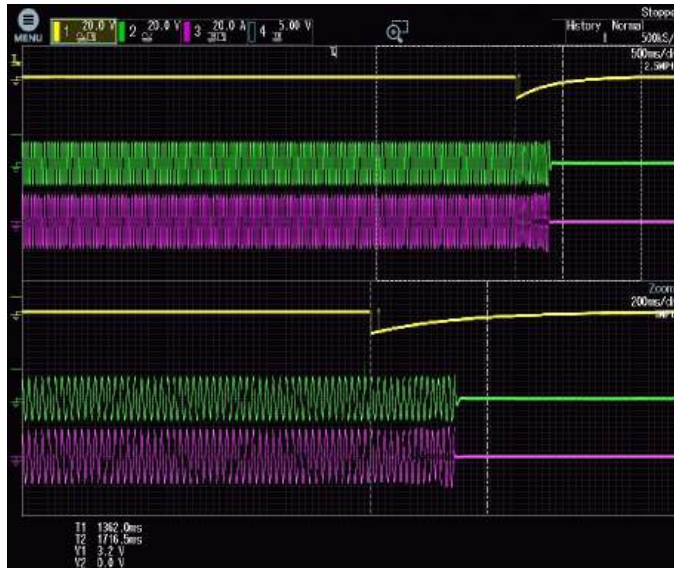

33% Unbalanced condition





URS PRODUCTS AND TESTING PRIVATE LIMITED

A-29, Sector-5, Noida-201301
T +91 (120) 4516264-65 F +91 (120) 4750296
E info@urs-labs.com W www.urs-labs.com
CIN NO U21014UP1987PTC008956



Report No- SC25SPI00628_1

IS 16169:2014 / IEC 62116 : 2008

Page 35 of 35

Dated : 17/04/2025

Clause	Requirement + Test	Result - Remark	Verdict
--------	--------------------	-----------------	---------

BLOCK DIAGRAM OF TEST CIRCUIT

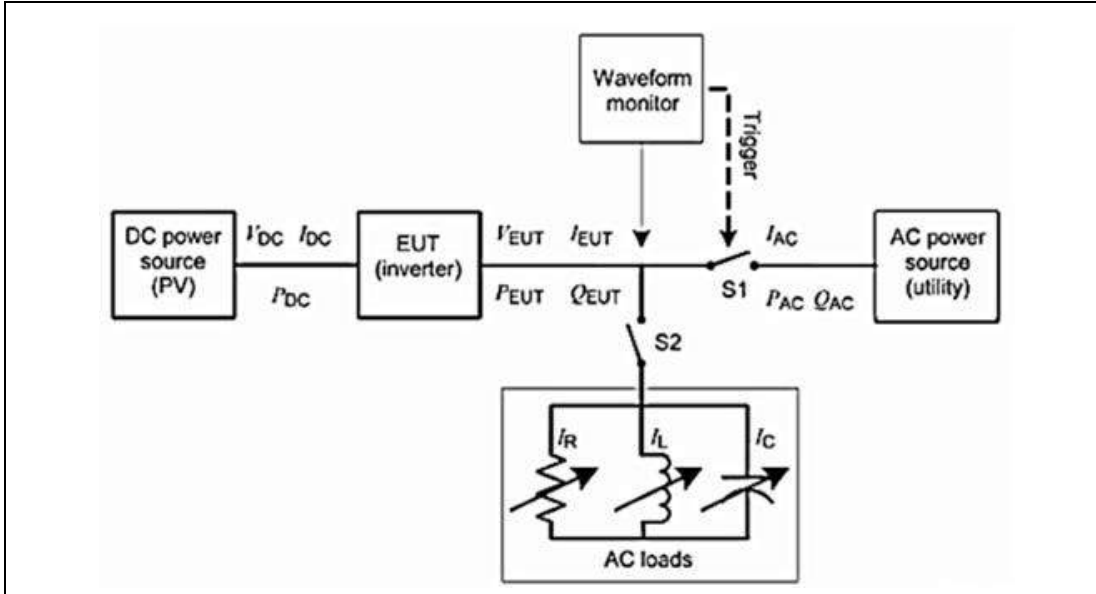

-----End of test Report-----





URS PRODUCTS AND TESTING PRIVATE LIMITED

A-29, Sector-5, Noida-201301
T +91 (120) 4516264-65 F +91 (120) 4750296
E info@urs-labs.com W www.urs-labs.com
CIN NO U21014UP1987PTC008956



SUMMARY OF TEST REPORT

TEST REPORT NO:SC25SPI00626_1

DATED:17/04/2025

(Number of pages in test report: Page no. 1 to 89)

TEST FORMAT AS PER IS 16221 (Part 2): 2015/IEC 62109-2 : 2011

1. Name of Manufacturer:KSOLARE ENERGY PVT LTD,
2. Product:Solar GTI (Power Invertors for use in Photovoltaic Power Systems)
Lead Model:KSY-6.2KW-1P-22A
Series Models:KSY-5.4KW-1P-22A, KSY-6KW-1P-22A, KSY-5KW-1P-22A, KSY-4.4KW-1P-22A, KSY-4KW-1P-22A, KSY-3.4KW-1P-22A, KSY-3KW-1P-22A, KSY-2KW-1P-22A, KSY-1KW-1P-22A
3. Model(s):
4. Model differences provided (if applicable):Yes
5. Model differences verified as per Guidelines for series formulation:Yes
6. Test Results:Refer below

PART A: GENERAL

S No.	TEST REQUIREMENT	CLAUSE	VERDICT
1.	General testing requirements	4	Pass
2.	Marking and documentation	5	Pass
3.	Environmental requirements and conditions	6	Pass
4.	Protection Against Electrical Shock and energy hazards	7	Pass
5.	Protection Against mechanical hazards	8	Pass
6.	Protection Against fire hazards	9	Pass
7.	Protection Against sonic pressure hazards	10	Pass
8.	Protection Against liquid hazards	11	N/A
9.	Protection Against chemical hazards	12	N/A
10.	Physical requirements	13	Pass
11.	Components	14	Pass





URS PRODUCTS AND TESTING PRIVATE LIMITED

A-29, Sector-5, Noida-201301
T +91 (120) 4516264-65 F +91 (120) 4750296
E info@urs-labs.com W www.urs-labs.com
CIN NO U21014UP1987PTC008956



General Information:

The conformity certificates of critical components are verified to ensure complete testing of apparatus under test and details regarding harmonized IEC standards (where IEC standards are not available) are also provided in the list of critical component.

CONCLUSION:

- 1.) Sample meets all relevant requirements of IS 16221 (Part 2): 2015/IEC 62109-2 : 2011 Yes
- 2.) Sample fails to meet the following test requirements: N/A
- 3) I hereby, undertake that the verdict stated in the test report for all the tests matches with the test results.

(Signature of Authorized person with Stamp)



URS PRODUCTS AND TESTING PRIVATE LIMITED

A-29, Sector-5, Noida-201301
T +91 (120) 4516264-65 F +91 (120) 4750296
E info@urs-labs.com W www.urs-labs.com
CIN NO U21014UP1987PTC008956



TC-6468

Report No- SC25SPI00626_1

IS 16221 (Part 2) : 2015/ IEC 62109-2 : 2011

Page 1 of 89

Dated : 17/04/2025

Manufacturer	KSOLARE ENERGY PVT LTD, SR NO.62, HISSA NO.3, MANGADEWADI, KATRAJ, PUNE SATARA ROAD, PUNE, MAHARASHTRA, PIN 411046, MAHARASHTRA, 411046		
Test item:	Solar GTI (Power Invertors for use in Photovoltaic Power Systems)		
Identification	Lead Model:KSY-6.2KW-1P-22A Series Model:KSY-5.4KW-1P-22A, KSY-6KW-1P-22A, KSY-5KW-1P-22A, KSY-4.4KW-1P-22A, KSY-4KW-1P-22A, KSY-3.4KW-1P-22A, KSY-3KW-1P-22A, KSY-2KW-1P-22A, KSY-1KW-1P-22A	Serial No.:	Refer page no. 5
Receipt No.:	URS/LAB/SPIV/24-25/B153E6D5 / 25EB00AN	Date of receipt:	12/03/2025
Testing laboratory and its address:	URS PRODUCTS AND TESTING PRIVATE LIMITED A-29, Sector-5, Noida-201301		
Test specification:	IS 16221 (Part 2) : 2015/ IEC 62109-2 : 2011 /		
Test Result:	The test item passed the test specification(s)		
Other Aspects:	Nil		
This test report relates to the test sample submitted and list of documents attached.			

Tested by:	Approved by / Authorized Signatory:	Issued by:
Shashi Prakash , Asst.Manager	PUJA KUMARI , Manager Technical	Paras Singh , Vice President (Technical)
Date: 17/04/2025	Date: 17/04/2025	Date: 17/04/2025



URS PRODUCTS AND TESTING PRIVATE LIMITED

A-29, Sector-5, Noida-201301
T +91 (120) 4516264-65 F +91 (120) 4750296
E info@urs-labs.com W www.urs-labs.com
CIN NO U21014UP1987PTC008956



Report No- SC25SPI00626_1

IS 16221 (Part 2) : 2015/ IEC 62109-2 : 2011

Page 2 of 89

Dated : 17/04/2025

TEST REPORT IS 16221 (Part 2) : 2015/ IEC 62109-2 : 2011 Safety of Power Converter for use in Photovoltaic Power System Part 2:Particular requirements for Inverter	
Report Reference No. :	SC25SPI00626_1
Date of issue :	17/04/2025
Total number of pages	89
Customer name :	KSOLARE ENERGY PVT LTD,
Address	SR NO.62, HISSA NO.3, MANGADEWADI, KATRAJ, PUNE SATARA ROAD, PUNE, MAHARASHTRA, PIN 411046, MAHARASHTRA, 411046
Test specification:	
Standard	IS 16221 (Part 2) : 2015/ IEC 62109-2 : 2011
Test procedure	Compliance Report
Non-standard test method	N/A
Test Report Form No:	TRF No. IS 16221 (Part 2) : 2015_V1.0
Test Report Form(s) Originator	BIS
Master TRF	Dated: 03.10.2018
Test item description:	Solar GTI (Power Invertors for use in Photovoltaic Power Systems)
Trade Mark	
Model/Type reference	Lead Model:KSY-6.2KW-1P-22A Series Model:KSY-5.4KW-1P-22A, KSY-6KW-1P-22A, KSY-5KW-1P-22A, KSY-4.4KW-1P-22A, KSY-4KW-1P-22A, KSY-3.4KW-1P-22A, KSY-3KW-1P-22A, KSY-2KW-1P-22A, KSY-1KW-1P-22A
Ratings	Refer marking label on page no. 5
Other Documents submitted	Please refer to Table – List of Attachments at Page No. 4

Tested by:	Approved by / Authorized Signatory:	Issued by:
Shashi Prakash , Asst.Manager	PUJA KUMARI , Manager Technical	Paras Singh , Vice President (Technical)
Date: 17/04/2025	Date: 17/04/2025	Date: 17/04/2025



URS PRODUCTS AND TESTING PRIVATE LIMITED

A-29, Sector-5, Noida-201301
T +91 (120) 4516264-65 F +91 (120) 4750296
E info@urs-labs.com W www.urs-labs.com
CIN NO U21014UP1987PTC008956



TC-6468



Report No- SC25SPI00626_1

IS 16221 (Part 2) : 2015/ IEC 62109-2 : 2011

Page 3 of 89

Dated : 17/04/2025

Testing Procedure and testing location:

Testing Laboratory	URS PRODUCTS AND TESTING PRIVATE LIMITED	
Testing location/ address	A-29, Sector-5, Noida-201301	
Testing procedure:		
Tested by (name + signature):	Shashi Prakash , Asst.Manager	
Approved by (name + signature):	PUJA KUMARI , Manager Technical	



URS PRODUCTS AND TESTING PRIVATE LIMITED

A-29, Sector-5, Noida-201301
T +91 (120) 4516264-65 F +91 (120) 4750296
E info@urs-labs.com W www.urs-labs.com
CIN NO U21014UP1987PTC008956



Report No- SC25SPI00626_1

IS 16221 (Part 2) : 2015/ IEC 62109-2 : 2011

Page 4 of 89

Dated : 17/04/2025

Table – List of Attachments

Attachment No.	Attachment Description	No. of pages in Attachment
Attachment 1	Photo document	06 pages (84-89)

Summary of Testing

<p>Tests performed (name of test and test clause):</p> <ul style="list-style-type: none"> Cl. 4 General testing requirements Cl. 5 Marking and documentation Cl. 6 Environmental requirements and conditions Cl. 7 Protection against electric shock and energy hazards Cl. 8 Protection against mechanical hazards Cl. 9 Protection against fire hazards Cl. 10 Protection against sonic pressure hazards Cl. 13 Physical requirements Cl. 14 Components 	<p>Testing location:</p> <p>URS PRODUCTS AND TESTING PRIVATE LIMITED A-29, Sector 5, Noida-201301, India</p>
--	---





URS PRODUCTS AND TESTING PRIVATE LIMITED

A-29, Sector-5, Noida-201301
T +91 (120) 4516264-65 F +91 (120) 4750296
E info@urs-labs.com W www.urs-labs.com
CIN NO U21014UP1987PTC008956



Report No- SC25SPI00626_1

IS 16221 (Part 2) : 2015/ IEC 62109-2 : 2011

Page 5 of 89

Dated : 17/04/2025

Copy of marking plate:

Copy of marking label:



KSY 6.2KW-1P-22A

Max. input voltage	550Vdc
MPPT voltage range	70-550V
Max. input current	22A+22A
Nominal DC input voltage	360V
Isc PV	26A
Protection Class	I
Vac/Fac Normal	230Vac/50Hz
Max. output current	26.95A
Rated AC output power	6200W
MFG Date	21/02/25
Power Factor	0.8Lead...1...0.8Lag
Operating Temp. range	-25 to +60 deg. C
Deg. of protection	IP 65



K SOLARE ENERGY PVT. LTD.
SR NO.82, HISSA NO.3, MANGADEWADI,
KATRAJ, PUNE SATARA ROAD, PUNE -411048,
INDIA
www.ksolare.com

Marking Label of Lead Model

Sample Code	Serial no.
Sample - 1	KSY0225HS2262
Sample - 2	KSY0225HS2263





URS PRODUCTS AND TESTING PRIVATE LIMITED

A-29, Sector-5, Noida-201301
T +91 (120) 4516264-65 F +91 (120) 4750296
E info@urs-labs.com W www.urs-labs.com
CIN NO U21014UP1987PTC008956



Report No- SC25SPI00626_1

IS 16221 (Part 2) : 2015/ IEC 62109-2 : 2011

Page 6 of 89

Dated : 17/04/2025

 POWER LED	ON=Inverter is feeding power
	BLINK=DC is on, but the inverter is not feeding power
	OFF=DC is off
 FAULT LED	ON=Inverter is faulty
	OFF=No fault
 COM LED	BLINK=Communication device is connected to inverter
	OFF=No communication
⚠ WARNING	
	Danger to life due to high voltages ! Only qualified personnel can open and service the product !
	Disconnect the inverter from all the external power sources before service !
	Do not touch live parts until 5 minutes after disconnection from the sources !
	Hot surface ! May exceed 60°C !
	Check user manual before services !

Warning Statement





URS PRODUCTS AND TESTING PRIVATE LIMITED

A-29, Sector-5, Noida-201301
T +91 (120) 4516264-65 F +91 (120) 4750296
E info@urs-labs.com W www.urs-labs.com
CIN NO U21014UP1987PTC008956



TC-6468

Report No- SC25SPI00626_1

IS 16221 (Part 2) : 2015/ IEC 62109-2 : 2011

Page 7 of 89

Dated : 17/04/2025



KSY 5.4KW-1P-22A

Max. input voltage	550Vdc
MPPT voltage range	70-550V
Max. input current	22A+22A
Nominal DC input voltage	360V
Isc PV	26A
Protection Class	I
Vac/Fac Normal	230Vac/50Hz
Max. output current	23.47A
Rated AC output power	5400W
MFG Date	21/02/25
Power Factor	0.8Lead...1...0.8Lag
Operating Temp. range	-25 to +60 deg. C
Deg. of protection	IP 65

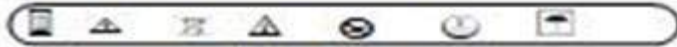

K SOLARE ENERGY PVT. LTD.
SR NO.82, HISSA NO.3, MANGADEWADI,
KATRAJ, PUNE SATARA ROAD, PUNE -411048,
INDIA
www.ksolare.com

Marking Label of Series Model





URS PRODUCTS AND TESTING PRIVATE LIMITED

A-29, Sector-5, Noida-201301
T +91 (120) 4516264-65 F +91 (120) 4750296
E info@urs-labs.com W www.urs-labs.com
CIN NO U21014UP1987PTC008956



Report No- SC25SPI00626_1

IS 16221 (Part 2) : 2015/ IEC 62109-2 : 2011

Page 8 of 89

Dated : 17/04/2025



KSY 6KW-1P-22A

Max. input voltage	550Vdc
MPPT voltage range	70-550V
Max. input current	22A
Nominal DC input voltage	360V
Isc PV	26A
Protection Class	I
Vac/Fac Normal	230Vac/50Hz
Max. output current	26.08A
Rated AC output power	6000W
MFG Date	21/02/25
Power Factor	0.8Lead...1...0.8Lag
Operating Temp. range	-25 to +60 deg. C
Deg. of protection	IP 65

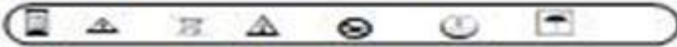

K SOLARE ENERGY PVT. LTD.
SR NO.82 HIS SA NO.3, MANGADEVADI,
KATRAJ, PUNE SATARA ROAD, PUNE -411048,
INDIA
www.ksolare.com

Marking Label of Series Model





URS PRODUCTS AND TESTING PRIVATE LIMITED

A-29, Sector-5, Noida-201301
T +91 (120) 4516264-65 F +91 (120) 4750296
E info@urs-labs.com W www.urs-labs.com
CIN NO U21014UP1987PTC008956



TC-6468

Report No- SC25SPI00626_1

IS 16221 (Part 2) : 2015/ IEC 62109-2 : 2011

Page 9 of 89

Dated : 17/04/2025



KSY 5KW-1P-22A

Max. input voltage	550Vdc
MPPT voltage range	70-550V
Max. input current	22A
Nominal DC input voltage	360V
Isc PV	26A
Protection Class	I
Vac/Fac Normal	230Vac/50 Hz
Max. output current	21.73A
Rated AC output power	5000W
MFG Date	21/02/25
Power Factor	0.8Lead...1...0.8Lag
Operating Temp. range	-25 to +60 deg. C
Deg. of protection	IP 65



SN: KSY0225HS2250



K SOLARE ENERGY PVT. LTD.
SR NO.62, HISSA NO.3, MANGADEWADI,
KATRAJ, PUNE SATARA ROAD, PUNE -411048,
INDIA
www.ksolare.com

Marking Label of Series Model





URS PRODUCTS AND TESTING PRIVATE LIMITED

A-29, Sector-5, Noida-201301
T +91 (120) 4516264-65 F +91 (120) 4750296
E info@urs-labs.com W www.urs-labs.com
CIN NO U21014UP1987PTC008956



Report No- SC25SPI00626_1

IS 16221 (Part 2) : 2015/ IEC 62109-2 : 2011

Page 10 of 89

Dated : 17/04/2025



KSY 4.4KW-1P-22A

Max. input voltage	550Vdc
MPPT voltage range	70-550V
Max. input current	22A
Nominal DC input voltage	360V
Isc PV	26A
Protection Class	I
Vac/Fac Normal	230Vac/50Hz
Max. output current	19.13A
Rated AC output power	4400W
MFG Date	21/02/25
Power Factor	0.8Lead...1...0.8Lag
Operating Temp. range	-25 to +60 deg. C
Deg. of protection	IP 65

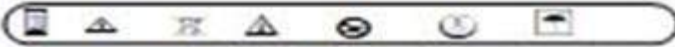

K SOLARE ENERGY PVT. LTD.
SR NO.62, HISSA NO.3, MANGADEWADI,
KATRAJ, PUNE SATARA ROAD, PUNE -411048,
INDIA
www.ksolare.com

Marking Label of Series Model





URS PRODUCTS AND TESTING PRIVATE LIMITED

A-29, Sector-5, Noida-201301
T +91 (120) 4516264-65 F +91 (120) 4750296
E info@urs-labs.com W www.urs-labs.com
CIN NO U21014UP1987PTC008956



Report No- SC25SPI00626_1

IS 16221 (Part 2) : 2015/ IEC 62109-2 : 2011

Page 11 of 89

Dated : 17/04/2025



KSY 4KW-1P-22A

Max. input voltage	550Vdc
MPPT voltage range	70-550V
Max. input current	22A
Nominal DC input voltage	360V
Isc PV	26A
Protection Class	I
Vac/Fac Normal	230Vac/50Hz
Max. output current	18.2A
Rated AC output power	4000W
MFG Date	21/02/25
Power Factor	0.8Lead...1...0.8Lag
Operating Temp. range	-25 to +60 deg. C
Deg. of protection	IP 65



K SOLARE ENERGY PVT. LTD.
SR NO.82 HISSA NO.3, MANGADEWADI,
KATRAJ, PUNE SATARA ROAD, PUNE -411048,
INDIA
www.ksolare.com

Marking Label of Series Model





URS PRODUCTS AND TESTING PRIVATE LIMITED

A-29, Sector-5, Noida-201301
T +91 (120) 4516264-65 F +91 (120) 4750296
E info@urs-labs.com W www.urs-labs.com
CIN NO U21014UP1987PTC008956



TC-6468

Report No- SC25SPI00626_1

IS 16221 (Part 2) : 2015/ IEC 62109-2 : 2011

Page 12 of 89

Dated : 17/04/2025



KSY 3.4KW-1P-22A

Max. input voltage	550Vdc
MPPT voltage range	70-550V
Max. input current	22A
Nominal DC input voltage	360V
Isc PV	26A
Protection Class	I
Vac/Fac Normal	230Vac/50Hz
Max. output current	14.78A
Rated AC output power	3400W
MFG Date	21/02/25
Power Factor	0.8Lead...1...0.8Lag
Operating Temp. range	-25 to +60 deg. C
Deg. of protection	IP 65



K SOLARE ENERGY PVT. LTD.
SR NO.82, HIS SA NO.3, MANGADEWADI,
KATRAJ, PUNE SATARA ROAD, PUNE -411048,
INDIA
www.ksolare.com

Marking Label of Series Model





URS PRODUCTS AND TESTING PRIVATE LIMITED

A-29, Sector-5, Noida-201301
T +91 (120) 4516264-65 F +91 (120) 4750296
E info@urs-labs.com W www.urs-labs.com
CIN NO U21014UP1987PTC008956



TC-6468

Report No- SC25SPI00626_1

IS 16221 (Part 2) : 2015/ IEC 62109-2 : 2011

Page 13 of 89

Dated : 17/04/2025



KSY 3KW-1P-22A

Max. input voltage	550Vdc
MPPT voltage range	70-550V
Max. input current	22A
Nominal DC input voltage	360V
Isc PV	26A
Protection Class	I
Vac/Fac Normal	230Vac/50Hz
Max. output current	13.04A
Rated AC output power	3000W
MFG Date	21/02/25
Power Factor	0.8Lead...1...0.8Lag
Operating Temp. range	-25 to +60 deg. C
Deg. of protection	IP 65



K SOLARE ENERGY PVT. LTD.
SR NO.62, HIS SA NO.3, MANGADEWADI,
KATRAJ, PUNE SATARA ROAD, PUNE -411048,
INDIA
www.ksolare.com

Marking Label of Series Model





URS PRODUCTS AND TESTING PRIVATE LIMITED

A-29, Sector-5, Noida-201301
T +91 (120) 4516264-65 F +91 (120) 4750296
E info@urs-labs.com W www.urs-labs.com
CIN NO U21014UP1987PTC008956



TC-6468

Report No- SC25SPI00626_1

IS 16221 (Part 2) : 2015/ IEC 62109-2 : 2011

Page 14 of 89

Dated : 17/04/2025



KSY 2KW-1P-22A

Max. input voltage	550Vdc
MPPT voltage range	70-550V
Max. input current	22A
Nominal DC input voltage	360V
Isc PV	26A
Protection Class	I
Vac/Fac Normal	230Vac/50Hz
Max. output current	8.69A
Rated AC output power	2000W
MFG Date	21/02/25
Power Factor	0.8Lead...1...0.8Lag
Operating Temp. range	-25 to +60 deg. C
Deg. of protection	IP 65

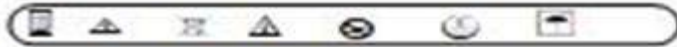

K SOLARE ENERGY PVT. LTD.
SR NO.82 HIS SA NO.3, MANGADEWADI,
KATRAJ, PUNE SATARA ROAD, PUNE -411048,
INDIA
www.ksolare.com

Marking Label of Series Model





URS PRODUCTS AND TESTING PRIVATE LIMITED

A-29, Sector-5, Noida-201301
T +91 (120) 4516264-65 F +91 (120) 4750296
E info@urs-labs.com W www.urs-labs.com
CIN NO U21014UP1987PTC008956



Report No- SC25SPI00626_1

IS 16221 (Part 2) : 2015/ IEC 62109-2 : 2011

Page 15 of 89

Dated : 17/04/2025



KSY IKW-1P-22A

Max. input voltage	550Vdc
MPPT voltage range	70-550V
Max. input current	22A
Nominal DC input voltage	360V
Isc PV	26A
Protection Class	I
Vac/Fac Normal	230Vac/50Hz
Max. output current	4.33A
Rated AC output power	1000W
MFG Date	21/02/25
Power Factor	0.8Lead...1...0.8Lag
Operating Temp. range	-25 to +60 deg. C
Deg. of protection	IP 65



K SOLARE ENERGY PVT. LTD.
SR NO.82, HISSA NO.3, MANGADEWADI,
KATRAJ, PUNE SATARA ROAD, PUNE -411048,
INDIA
www.ksolare.com

Marking Label of Series Model





URS PRODUCTS AND TESTING PRIVATE LIMITED

A-29, Sector-5, Noida-201301
T +91 (120) 4516264-65 F +91 (120) 4750296
E info@urs-labs.com W www.urs-labs.com
CIN NO U21014UP1987PTC008956



Report No- SC25SPI00626_1

IS 16221 (Part 2) : 2015/ IEC 62109-2 : 2011

Page 16 of 89

Dated : 17/04/2025

Test item particulars	SOLAR GTI (Power Invertors for use in Photovoltaic Power Systems)
Equipment mobility	<input type="checkbox"/> movable <input type="checkbox"/> hand-held <input type="checkbox"/> stationary <input checked="" type="checkbox"/> fixed <input type="checkbox"/> transportable <input type="checkbox"/> for_building_in
Connection to the mains	<input type="checkbox"/> pluggable equipment <input type="checkbox"/> direct plug in <input checked="" type="checkbox"/> permanent connection <input type="checkbox"/> for_building_in
Enviromental category	<input checked="" type="checkbox"/> outdoor <input type="checkbox"/> indoor unconditional <input type="checkbox"/> indoor conditional
Over voltage category (OVC) mains	<input type="checkbox"/> OVC I <input type="checkbox"/> OVC II <input checked="" type="checkbox"/> OVC III <input type="checkbox"/> OVC IV
Over voltage category (PV)	<input type="checkbox"/> OVC I <input checked="" type="checkbox"/> OVC II <input type="checkbox"/> OVC III <input type="checkbox"/> OVC IV
Mains supply tolerance (%)	-90 / +110 %
Tested for power systems	Yes
IT testing, phase-phase voltage (V)	N/A
Class of equipment	<input checked="" type="checkbox"/> Class I <input type="checkbox"/> Class II <input type="checkbox"/> Class III <input type="checkbox"/> Not classified
Mass of equipment (kg)	10.01Kg (Approx)
Pollution degree (PD)	<input type="checkbox"/> PD 1 <input type="checkbox"/> PD 2 <input checked="" type="checkbox"/> PD 3
IP protection class	IP65
Possible test case verdicts:	
- test case does not apply to the test object :N/A	
- test object does meet the requirement :P (Pass)	
- test object was not evaluated for the requirement :N/E	
- test object does not meet the requirement :F (Fail)	





URS PRODUCTS AND TESTING PRIVATE LIMITED

A-29, Sector-5, Noida-201301
T +91 (120) 4516264-65 F +91 (120) 4750296
E info@urs-labs.com W www.urs-labs.com
CIN NO U21014UP1987PTC008956



TC-5468

Report No- SC25SPI00626_1

IS 16221 (Part 2) : 2015/ IEC 62109-2 : 2011

Page 17 of 89

Dated : 17/04/2025

Testing:

Date of receipt of test item: 12/03/2025

Date(s) of performance of tests: 13/03/2025 to 17/04/2025

General remarks:

The test results presented in this report relate only to the object tested.
This report shall not be reproduced, except in full, without the written approval of the Issuing testing laboratory.

Manufacturer's Declaration per Standard:

Similarities between the models: Representative models and series models have following similarities

- 1) Same rated Input/ Output voltage, Input voltage
- 2) Same frequency
- 3) Number of Phases at output
- 4) Same PCB design and layout
- 5) Same Power Stage topology
- 6) Same Insulation Class
- 7) Same Control Algorithm/firmware
- 8) Same Cabinet Design
- 9) Class of construction

Differences between the models: Representative models and series models have following differences
Model name and electrical ratings (as per capacity).





URS PRODUCTS AND TESTING PRIVATE LIMITED

A-29, Sector-5, Noida-201301
T +91 (120) 4516264-65 F +91 (120) 4750296
E info@urs-labs.com W www.urs-labs.com
CIN NO U21014UP1987PTC008956



Report No- SC25SPI00626_1

IS 16221 (Part 2) : 2015/ IEC 62109-2 : 2011

Page 18 of 89

Dated : 17/04/2025

General product information:

1) Application details / Description of the product:

The product covered under this test report is a SOLAR GTI (Power Invertors for use in Photovoltaic Power Systems).

The details of the product are stated below:

Manufacturer: KSOLARE ENERGY PVT LTD

Ratings:

Input rating: Max Input Voltage: 550Vdc, MPPT Voltage Range: 70-550Vdc, Max Input Current: 22+22A, Nominal DC input voltage: 360V, Isc PV: 26A, Vac/Fac Nominal: 230Vac/50Hz, Max. output Current: 26.95A, Rated AC output power: 6200W, Power Factor: 0.8Lead..1..0.8Lag, Protective Class: Class I, Operating Temp. range: -25°C ~60°C, Deg. of protection: IP 65

All the applicable test has been carried out on Lead Model "KSY-6.2KW-1P-22A" and meeting the requirement of IS 16221 (Part 2): 2015/ IEC 62109-2: 2011 in conjunction with IS 16221 (Part1):2016 / IEC 62109-1:2010.





URS PRODUCTS AND TESTING PRIVATE LIMITED

A-29, Sector-5, Noida-201301
T +91 (120) 4516264-65 F +91 (120) 4750296
E info@urs-labs.com W www.urs-labs.com
CIN NO U21014UP1987PTC008956



Report No- SC25SPI00626_1

IS 16221 (Part 2) : 2015/ IEC 62109-2 : 2011

Page 19 of 89

Dated : 17/04/2025

Clause	Requirement + Test	Result - Remark	Verdict
4	General testing requirements	See below	P
4.1 /RD	General	Test carried out under reference test conditions and under both normal & single fault conditions.	P
4.2/RD	General conditions for testing	See below	P
4.2.1/RD	Sequence of tests	Considered as per MNRE guidelines	P
4.2.2/RD	Reference test conditions	See below	P
4.2.2.1/RD	Environmental conditions	Temperature:15 to 40°C Relative humidity: not more than 75% Air pressure: 75kPa to 106kPa No frost, dew, percolating water, rain, solar radiation	P
4.2.2..2/RD	State of equipment	All tests have been carried out on model which represent the future production unit with complete assemblies	P
4.2.2.3/RD	Position of equipment	The equipment were installed in accordance with the manufacturer's instructions	P
4.2.2.4/RD	Accessories	No accessories or operator Interchangeable parts used.	N/A
4.2.2.5/RD	Covers and removable parts	No covers and removable parts	N/A
4.2.2.6/RD	Mains supply a) Voltage: b) Frequency: c) Polarity: d) Earthing: e) Over-current Protection:	a) Voltage:230V b) Frequency : 50Hz c) Polarity: Not for pluggable equipment type A d) Earthing provided e) Over-current Protection: 28A	P
4.2.2.7/RD	Supply ports other than the mains	See below	P
4.2.2.7.1/RD	Photovoltaic supply sources a) Open circuit voltage: b) Short-circuit current:	PV array simulator used with suitable compatibility	P
4.2.2.7.2/RD	Battery inputs	No battery used	N/A
4.2.2.8/RD	Conditions of loading for output ports	DC to AC inverter. A.C. output port was loaded with linear loads to obtain the maximum rated output power. Continuous operation ratings, until steady conditions are established.	P
4.2.2.9 /RD	Earthing terminals	Protective conductor terminal was connected to earth. No functional earth terminal.	P
4.2.2.10/RD	Controls	No mains selection devices and No combinations of settings devices	N/A
4.2.2.11/RD	Available short circuit current	Considered	p
4.3/RD	Thermal testing	See appended table 4.3	P
4.3.1/RD	General	See appended table 4.3	P
4.3.2/RD	Maximum temperatures	See appended table 4.3	P
4.3.2.1/RD	General	See appended table 4.3	P
4.3.2.2/RD	Touch temperatures	See appended table 4.3	P





URS PRODUCTS AND TESTING PRIVATE LIMITED

A-29, Sector-5, Noida-201301
 T +91 (120) 4516264-65 F +91 (120) 4750296
 E info@urs-labs.com W www.urs-labs.com
 CIN NO U21014UP1987PTC008956



Report No- SC25SPI00626_1

IS 16221 (Part 2) : 2015/ IEC 62109-2 : 2011

Page 20 of 89

Dated : 17/04/2025

Clause	Requirement + Test	Result - Remark	Verdict
4.3.2.3/RD	Temperatures limits for mounting surfaces	See appended table 4.3	P
4.4/RD	Testing in single fault condition	See appended table 4.4	P
4.4.1/RD	General	See appended table 4.4	P
4.4.2/RD	Test conditions and duration for testing under fault conditions	See below	P
4.4.2.1/RD	General	Considered	P
4.4.2.2/RD	Duration of tests	Considered	P
4.4.3/RD	Pass/fail criteria for testing under fault conditions	See below	P
4.4.3.1/RD	Protection against shock hazard	No shock hazards	P
4.4.3.2/RD	Protection against the spread of fire	No spread of fire	P
4.4.3.3/RD	Protection against other hazards	No other hazards	P
4.4.3.4/RD	Protection against parts expulsion hazards	No expulsion hazards	P
4.4.4	Single fault conditions to be applied	See below	P
4.4.4.1/RD	Component fault tests	See appended table 4.4	P
4.4.4.2 /RD	Equipment or parts for short-term or intermittent operation	For continuous operation	N/A
4.4.4.3 /RD	Motors	See appended table 4.4	P
4.4.4.4/RD	Transformer short circuit tests	See appended table 4.4	P
4.4.4.5/RD	Output short circuit	See appended table 4.4	P
4.4.4.6/RD	Backfeed current test for equipment with more than one source of supply	Only single source of supply used	N/A
4.4.4.7/RD	Output overload	See appended table 4.4	P
4.4.4.8/RD	Cooling system failure	See appended table 4.4	P
4.4.4.9/RD	Heating devices	No heating devices used	N/A
4.4.4.10/RD	Safety interlock systems	No such system used	N/A
4.4.4.11/RD	Reverse d.c. connections	Instructions provide in installation manual	P
4.4.4.12/RD	Voltage selector mismatch	No voltage selector	N/A
4.4.4.13/RD	Mis-wiring with incorrect phase sequence or polarity	No hazards observed	P
4.4.4.14/RD	Printed wiring board short-circuit test	See appended table 4.4	P
4.4.4.15	Fault-tolerance of protection for grid-interactive inverters	See below	P
4.4.4.15.1	Fault-tolerance of residual current monitoring according to 4.8.3.5: the residual current monitoring system operates properly	See appended table 4.4.4.15.1	P
	a). - The inverter ceases to operate	See above clause 4.4.4.15.1	P
	- Indicates a fault in accordance with 13.9	See above clause 4.4.4.15.1	P
	- Disconnect from the mains	See above clause 4.4.4.15.1	P
	- not re-connect after any sequence of removing and reconnecting PV power	See above clause 4.4.4.15.1	P
	- not re-connect after any sequence of removing and reconnecting AC power	See above clause 4.4.4.15.1	P





URS PRODUCTS AND TESTING PRIVATE LIMITED

A-29, Sector-5, Noida-201301
 T +91 (120) 4516264-65 F +91 (120) 4750296
 E info@urs-labs.com W www.urs-labs.com
 CIN NO U21014UP1987PTC008956



Report No- SC25SPI00626_1

IS 16221 (Part 2) : 2015/ IEC 62109-2 : 2011

Page 21 of 89

Dated : 17/04/2025

Clause	Requirement + Test	Result - Remark	Verdict
	- not re-connect after any sequence of removing and reconnecting both PV and AC power	See above clause 4.4.4.15.1	P
	b). - The inverter continues to operate	Inverter ceases to operate	N/A
	- the residual current monitoring system operates properly under single fault condition	See above clause 4.4.4.15.1	N/A
	- Indicates a fault in accordance with 13.9	See above clause 4.4.4.15.1	N/A
	c). - The inverter continues to operate regardless of loss of residual current monitoring functionality	Inverter ceases to operate	N/A
	- not re-connect after any sequence of removing and reconnecting PV power	See above clause 4.4.4.15.1	N/A
	- not re-connect after any sequence of removing and reconnecting AC power	See above clause 4.4.4.15.1	N/A
	- not re-connect after any sequence of removing and reconnecting both PV and AC power	See above clause 4.4.4.15.1	N/A
	- Indicates a fault in accordance with 13.9	See above clause 4.4.4.15.1	N/A
4.4.4.15.2	Fault-tolerance of automatic disconnecting means	Considered	P
4.4.4.15.2.1	The means provided for automatic disconnection of a grid-interactive inverter from the mains shall:	See below	P
	- disconnect all grounded current-carrying conductors from the mains	Disconnected all grounded current carrying conductors from the mains	P
	- disconnect all ungrounded current-carrying conductors from the mains	Disconnected all ungrounded current carrying conductors from the mains	P
	- be such that with a single fault applied to the disconnection means or to any other location in the inverter, at least basic insulation or simple separation is maintained between the PV array and the mains when the disconnecting means is intended to be in the open state.	Basic insulation is maintained between PV array and mains	P
4.4.4.15.2.2	Design of insulation or separation complies with requirements of 7.3.7 of Part 1: report here Part 1 comment and verdict	Complies	P
4.4.4.15.2.3	For non-isolated inverter, automatic checking of the isolation provided by a disconnect means after single fault.	The inverter automatic checking of the isolation after single fault occurred	P
	If the check fail: - any still-functional disconnection means shall be left in the open position	Complies	P
	- at least basic or simple separation shall be maintained between the PV input and the mains	Basic insulation is maintained between PV array and mains	P
	- the inverter shall not start operation	Complies	P
	the inverter shall indicate a fault in accordance with 13.9	The screen shows error information	P
4.4.4.16	A stand-alone inverter with a transfer switch to transfer AC loads from the mains or other AC bypass source to the inverter output:	Not a stand-alone inverter	N/A
	- shall continue to operate normally	See above clause no. 4.4.4.16	N/A





URS PRODUCTS AND TESTING PRIVATE LIMITED

A-29, Sector-5, Noida-201301
 T +91 (120) 4516264-65 F +91 (120) 4750296
 E info@urs-labs.com W www.urs-labs.com
 CIN NO U21014UP1987PTC008956



Report No- SC25SPI00626_1

IS 16221 (Part 2) : 2015/ IEC 62109-2 : 2011

Page 22 of 89

Dated : 17/04/2025

Clause	Requirement + Test	Result - Remark	Verdict
	- shall not present a risk of fire as the result of an out-of-phase transfer	See above clause no. 4.4.4.16	N/A
	shall not present a risk of shock as the result of an out-of-phase transfer	See above clause no. 4.4.4.16	N/A
	- for an inverter employing a bypass switch having a control preventing switching, the test is to be conducted under the condition of a component malfunction	See above clause no. 4.4.4.16	N/A
4.4.4.17	Cooling system failure – Blanketing test No hazards according to the criteria of sub-clause 4.4.3 of Part 1 shall result from blanketing the inverter This test is not required for inverters restricted to use only in closed electrical operating areas.	See appended table 4.4.4.17	P
	Test stop condition: time duration value or stabilized temperature	See appended table 4.4.4.17	P
4.5/RD	Humidity preconditioning	See below	P
4.5.1/RD	General	Considered	P
4.5.2/RD	Conditions	Humidity: 92.5±2.5%RH Temperature: 40±2°C Duration: 48h	P
4.6/RD	Backfeed voltage protection	See below	P
4.6.1/RD	Backfeed tests under normal conditions	Input side: Positive to negative 20mV	P
4.6.2/RD	Backfeed tests under single-fault conditions	Input side: Positive to negative 26mV	P
4.6.3/RD	Compliance with backfeed tests	No hazards present after 15s	P
4.7	Electrical ratings tests	See below	P
4.7.1/RD	Input ratings	See appended table 4.7	P
4.7.1.1/RD	Measurement requirements for DC input ports	See appended table 4.7	P
4.7.2/ RD	Output ratings	See appended table 4.7	P
4.7.3	Measurement requirements for AC output ports for standalone inverters	Not a standalone inverter	N/A
4.7.4	Stand-alone Inverter AC output voltage and frequency	Not a standalone inverter	N/A
4.7.4.1	General	See above clause no. 4.7.4	N/A
4.7.4.2	Steady state output voltage at nominal DC input The steady-state AC output voltage shall not be less than 90 % or more than 110 % of the rated nominal voltage with the inverter supplied with its nominal value of DC input voltage.	See above clause no. 4.7.4	N/A
4.7.4.3	Steady state output voltage across the DC input range The steady-state AC output voltage shall not be less than 85 % or more than 110 % of the rated nominal voltage with the inverter supplied with any value within the rated range of DC input voltage.	See above clause no. 4.7.4	N/A
4.7.4.4	Load step response of the output voltage at nominal DC input The AC output voltage shall not be less than 85 % or more than 110 % of the rated nominal voltage for more than 1,5 s	See above clause no. 4.7.4	N/A





URS PRODUCTS AND TESTING PRIVATE LIMITED

A-29, Sector-5, Noida-201301
 T +91 (120) 4516264-65 F +91 (120) 4750296
 E info@urs-labs.com W www.urs-labs.com
 CIN NO U21014UP1987PTC008956



Report No- SC25SPI00626_1

IS 16221 (Part 2) : 2015/ IEC 62109-2 : 2011

Page 23 of 89

Dated : 17/04/2025

Clause	Requirement + Test	Result - Remark	Verdict
	after application or removal of a resistive load		
4.7.4.5	Steady state output frequency The steady-state AC output frequency shall not vary from the nominal value by more than +4 % or -6 %.	See above clause no. 4.7.4	N/A
4.7.5	Stand-alone inverter output voltage waveform	Not a standalone inverter	N/A
4.7.5.1	General	See above clause no. 4.7.5	N/A
4.7.5.2	The AC output voltage waveform of a sinusoidal output stand-alone inverter shall have a total harmonic distortion (THD) not exceeding of 10 % and no individual harmonic at a level exceeding 6 %.	See above clause no. 4.7.5	N/A
4.7.5.3	Non-sinusoidal output waveform requirements	Not a standalone inverter	N/A
4.7.5.3.1	General	See above clause no. 4.7.5.3	N/A
4.7.5.3.2	The total harmonic distortion (THD) of the voltage waveform shall not exceed 40 %.	See above clause no. 4.7.5.3	N/A
4.7.5.3.3	The slope of the rising and falling edges of the positive and negative half-cycles of the voltage waveform shall not exceed 10 V/ μ s measured between the points at which the waveform has a voltage of 10 % and 90 % of the peak voltage for that half-cycle.	See above clause no. 4.7.5.3	N/A
4.7.5.3.4	The absolute value of the peak voltage of the positive and negative half-cycles of the waveform shall not exceed 1,414 times 110 % of the RMS value of the rated nominal AC output voltage	See above clause no. 4.7.5.3	N/A
4.7.5.4	Information requirements for non-sinusoidal waveforms The instructions provided with a stand-alone inverter not complying with 4.7.5.2 shall include the information in 5.3.2.6.	See above clause no. 4.7.5.3	N/A
4.7.5.5	Output voltage waveform requirements for inverters for dedicated loads. For an inverter that is intended only for use with a known dedicated load, the following requirements may be used as an alternative to the waveform requirements in 4.7.5.2 to 4.7.5.3.	See above clause no. 4.7.5.3	N/A
	The combination of the inverter and dedicated load shall be evaluated to ensure that the output waveform does not cause any hazards in the load equipment and inverter, or cause the load equipment to fail to comply with the applicable product safety standards.	See above clause no. 4.7.5.3	N/A
	The inverter shall be marked with symbols 9 and 15 of Table C.1 of Part 1.	See above clause no. 4.7.5.3	N/A
	The installation instructions provided with the inverter shall include the information in 5.3.2.13	See above clause no. 4.7.5.3	N/A
4.8	Additional tests for grid-interactive inverters	See below	P





URS PRODUCTS AND TESTING PRIVATE LIMITED

A-29, Sector-5, Noida-201301
 T +91 (120) 4516264-65 F +91 (120) 4750296
 E info@urs-labs.com W www.urs-labs.com
 CIN NO U21014UP1987PTC008956



Report No- SC25SPI00626_1

IS 16221 (Part 2) : 2015/ IEC 62109-2 : 2011

Page 24 of 89

Dated : 17/04/2025

Clause	Requirement + Test	Result - Remark	Verdict
4.8.1	General requirements regarding inverter isolation and array grounding	Non-isolation inverter	N/A
	- Type of Array grounding supported	The EUT is intended to be used with ungrounded array	N/A
	Inverter isolation	Non-isolation inverter	N/A
4.8.2	Array insulation resistance detection for inverters for ungrounded and functionally grounded arrays	See below	P
4.8.2.1	Array insulation resistance detection for inverters for ungrounded arrays	See appended table 4.8.2	P
	Inverter shall have means to measure DC insulation resistance from PV input (array) to ground before starting operation	Complies	P
	Or Inverter shall be provided with instruction in accordance with 5.3.2.11.	The inverter can measure DC insulation resistance from PV input array to ground before starting operation	N/A
	Measured DC insulation resistance:	See appended table 4.8.2	P
	Inverter measurement circuit shall be capable of detecting insulation resistance below the limit value $R = V_{max}/30mA$ under normal conditions	Complies	P
	Inverter measurement circuit shall be capable of detecting insulation resistance below the limit value $R = V_{max}/30mA$ with ground fault in the PV array	Complies	P
	Isolated inverters shall indicate a fault if the insulation resistance is less than the limit value	The EUT is non-isolated inverter	N/A
	Isolated inverter fault indication maintained until insulation resistance has recovered to a value higher than the limit value	The EUT is non-isolated inverter	N/A
	Non-isolated inverters, or inverters with isolation not complying with the leakage current limits in the minimum inverter isolation requirements in Table 30:	See below	P
	- shall indicate a fault in accordance with 13.9	The screen shows fault information	P
	- shall not connect to the mains	Not connect to the mains	P
4.8.2.2	Array insulation resistance detection for inverters for functionally grounded arrays	Not a functionally grounded array	N/A
	a-1) The value of the total resistance, including the intentional resistance for array functional grounding, the expected insulation resistance of the array to ground, and the resistance of any other networks connected to ground (for example measurement networks) must not be lower than $R = (V_{MAX} PV/30 mA)$ ohms.	See above clause no. 4.8.2.2	N/A
	a-2) The installation instructions shall include the information required in 5.3.2.12.	See above clause no. 4.8.2.2	N/A





URS PRODUCTS AND TESTING PRIVATE LIMITED

A-29, Sector-5, Noida-201301
 T +91 (120) 4516264-65 F +91 (120) 4750296
 E info@urs-labs.com W www.urs-labs.com
 CIN NO U21014UP1987PTC008956



Report No- SC25SPI00626_1

IS 16221 (Part 2) : 2015/ IEC 62109-2 : 2011

Page 25 of 89

Dated : 17/04/2025

Clause	Requirement + Test	Result - Remark	Verdict
	b-1) As an alternative to a), or if a resistor value lower than in a) is used, the inverter shall incorporate means to detect, during operation, if the total current through the resistor and any networks (for example measurement networks) in parallel with it, exceeds the residual current values and times in Table 31	See above clause no. 4.8.2.2	N/A
	b-2) Inverter shall either disconnect the resistor or limit the current by other means	See above clause no. 4.8.2.2	N/A
	b-3) If the inverter is a non-isolated inverter, or has isolation not complying with the leakage current limits in the minimum inverter isolation requirements in Table 30, it shall also disconnect from the mains.	See above clause no. 4.8.2.2	N/A
	c) The inverter shall have means to measure the DC insulation resistance from the PV input to ground before starting operation, in accordance with 4.8.2.1.	See above clause no. 4.8.2.2	N/A
4.8.3	Array residual current detection	See below	P
4.8.3.1	General	General Complies	P
4.8.3.2	30 mA touch current type test for isolated inverters	The EUT is non-isolated inverter	N/A
4.8.3.3	Fire hazard residual current type test for isolated inverters	The EUT is non-isolated inverter	P
4.8.3.4	Protection by application of RCD's	The EUT provides an integral RCD	N/A
	- The requirement for additional protection in 4.8.3.1 can be met by provision of an RCD with a residual current setting of 30 mA, located between the inverter and the mains	See above clause no. 4.8.3.4	N/A
	- The selection of the RCD type to ensure compatibility with the inverter must be made according to rules for RCD selection in Part 1.	See above clause no. 4.8.3.4	N/A
	- The RCD provided integral to the inverter, or	See above clause no. 4.8.3.4	N/A
	- The RCD provided by the installer if details of the rating, type, and location for the RCD are given in the installation instructions per 5.3.2.9.	See above clause no. 4.8.3.4	N/A
4.8.3.5	Protection by residual current monitoring	See below	P
4.8.3.5.1	General	The EUT provides an integral RCD	P
	Where required by Table 30, the inverter shall provide residual current monitoring that functions whenever the inverter is connected to the mains with the automatic disconnection means closed.	The residual current measured before EUT start up	P
	The residual current monitoring means shall measure the total (both a.c. and d.c. components) RMS current	Complies	P
	As indicated in Table 30 for different inverter types, array types, and inverter isolation levels, detection may be required for excessive continuous residual current, excessive sudden changes in residual current, or both, according to the	Considered	P





URS PRODUCTS AND TESTING PRIVATE LIMITED

A-29, Sector-5, Noida-201301
 T +91 (120) 4516264-65 F +91 (120) 4750296
 E info@urs-labs.com W www.urs-labs.com
 CIN NO U21014UP1987PTC008956



Report No- SC25SPI00626_1

IS 16221 (Part 2) : 2015/ IEC 62109-2 : 2011

Page 26 of 89

Dated : 17/04/2025

Clause	Requirement + Test	Result - Remark	Verdict
	following limits:		
	a) Continuous residual current: The inverter shall disconnect within 0,3 s and indicate a fault in accordance with 13.9 if the continuous residual current exceeds:	See appended table 4.8.3.5	P
	- maximum 300 mA for inverters with continuous output power rating ≤ 30 kV;	In Compliance	P
	- maximum 10 mA per kVA of rated continuous output power for inverters with continuous output power rating > 30 kVA.	<30 kVA	N/A
	The inverter may attempt to re-connect if the array insulation resistance meets the limit in 4.8.2.	Complies	P
	b) Sudden changes in residual current: The inverter shall disconnect from the mains within the time specified in Table 31	See appended table 4.8.3.5	P
	The inverter indicates a fault in accordance with 13.9, if a sudden increase in the RMS residual current is detected exceeding the value in the table	See appended table 4.8.3.5	P
	The inverter may attempt to re-connect if the array insulation resistance meets the limit in 4.8.2.	Complies	P
4.8.3.5.2	Test for detection of excessive continuous residual current: test repeated 5 times and time to disconnect shall not exceed 0,3 s	See appended table 4.8.3.5.2	P
4.8.3.5.3	Test for detection of sudden changes in residual current repeated 5 times and each of the 5 results shall not exceed the time limit indicated in for each row (30mA, 60mA and 150mA) of Table 31.	See appended table 4.8.3.5.3	P
4.8.3.6	Systems located in closed electrical operating areas	Not located in the closed electrical operating area	N/A
	The protection against shock hazard is not required if the installation information provided with the inverter indicates the restriction for use in a closed electrical operating area, and	See above clause no. 4.8.3.6	N/A
	Installation information indicates what forms of shock hazard protection are and are not provided integral to the inverter, in accordance with 5.3.2.7.	See above clause no. 4.8.3.6	N/A
	The inverter shall be marked as in 5.2.2.6.	See above clause no. 4.8.3.6	N/A
5	MARKING AND DOCUMENTATION	See below	P
	.	See below	P
5.1	Marking	See below	P
5.1.1/RD General	General	See below	P
	Equipment shall bear markings as specified in 5.1 and 5.2	The marking plate is on the outer surface of enclosure	P





URS PRODUCTS AND TESTING PRIVATE LIMITED

A-29, Sector-5, Noida-201301
 T +91 (120) 4516264-65 F +91 (120) 4750296
 E info@urs-labs.com W www.urs-labs.com
 CIN NO U21014UP1987PTC008956



Report No- SC25SPI00626_1

IS 16221 (Part 2) : 2015/ IEC 62109-2 : 2011

Page 27 of 89

Dated : 17/04/2025

Clause	Requirement + Test	Result - Remark	Verdict
	Graphic symbols may be used and shall be in accordance with Annex C or IEC 60417 as applicable	All used graphical symbols are in accordance with annex C	P
	Graphic symbols shall be explained in the documentation provided with the PCE	The explanations are provided in the manual	P
5.1.2/RD	Durability of markings	See below	P
	Markings required by this clause to be located on the PCE shall remain clear and legible under conditions of NORMAL USE and resist the effects of cleaning agents specified by the manufacturer	The label was subjected to the permanence of marking test. The markings was rubbed quickly by hand, without undue pressure, for 30 s with a cloth soaked with the isopropyl alcohol. After the test, the markings are clearly legible There was neither loose nor curling on the edge of the label.	P
5.1.3/RD	Identification	See below	P
	The equipment shall, as a minimum, be permanently marked with:	See below	P
	a) the name or trade mark of the manufacturer or supplier	Trade mark :“  ” marked on the label	P
	b) model number, name or other means to identify the equipment	Model no.:KSY-6.2KW-1P-22A marked on the label	P
	c) a serial number, code or other marking allowing identification of manufacturing location and the manufacturing batch or date within a three month time period.	Serial no.: KSY0225HS2262, KSY0225HS2263 marked on the label	P
5.1.4	Equipment ratings	See below	P
	PV input ratings:	See below	P
	- Vmax PV (absolute maximum) (d.c. V)	550Vdc	P
	- Isc PV (absolute maximum) (d.c. A)	26A	P
	a.c. output ratings:	See below	P
	- Voltage (nominal or range) (a.c. V)	230V	P
	- Current (maximum continuous) (a.c. A)	26.95A	P
	- Frequency (nominal or range) (Hz)	50Hz	P
	- Power (maximum continuous) (W or VA)	6200W	P
	- Power factor range	0.8Leading~-0.8Lagging	P
	a.c input ratings:	No ac input used	P
	- Voltage (nominal or range) (a.c. V)	No ac input used	N/A
	- Current (maximum continuous) (a.c. A)	No ac input used	N/A
	- Frequency (nominal or range) (Hz)	No ac input used	N/A
	d.c. output ratings:	No dc output used	N/A
	- Voltage (nominal or range) (d.c. V)	No dc output used	N/A





URS PRODUCTS AND TESTING PRIVATE LIMITED

A-29, Sector-5, Noida-201301
 T +91 (120) 4516264-65 F +91 (120) 4750296
 E info@urs-labs.com W www.urs-labs.com
 CIN NO U21014UP1987PTC008956



Report No- SC25SPI00626_1

IS 16221 (Part 2) : 2015/ IEC 62109-2 : 2011

Page 28 of 89

Dated : 17/04/2025

Clause	Requirement + Test	Result - Remark	Verdict
	- Current (maximum continuous) (d.c. A)	No dc output used	N/A
	Protective class (I or II or III)	Class I	P
	Ingress protection (IP) rating per part 1	IP 65	P
	An inverter that is adjustable for more than one nominal output voltage shall be marked to indicate the particular voltage for which it is set when shipped from the factory.	No such application	N/A
5.1.5/RD	Fuse identification	No fuse used	N/A
	Marking shall be located adjacent to each fuse or fuseholder, or on the fuseholder, or in another location provided that it is obvious to which fuse the marking applies, giving the fuse current rating and where fuses of different voltage rating value could be fitted, the fuse voltage rating.	See above	N/A
	Where fuses with special fusing characteristics such as time delay or breaking capacity are necessary, the type shall also be indicated	See above	N/A
	For fuses not located in operator access areas and for soldered-in fuses located in operator access areas, it is permitted to provide an unambiguous cross-reference (for example, F1, F2, etc.) to the servicing instructions which shall contain the relevant information.	See above	N/A
5.1.6/RD	Terminals, Connections, and Controls	See below	P
	If necessary for safety, an indication shall be given of the purpose of Terminals, connectors, controls, and indicators, and their various positions, including any connections for coolant fluids such as water and drainage. The symbols in Annex C may be used, and where there is insufficient space, symbol 9 of Annex C may be used.	Symbol 9 are marked on the EUT and user manual indicate the installation and safety of connection of connector, control and indicator	P
	Push-buttons and actuators of emergency stop devices, and indicator lamps used only to indicate a warning of danger or the need for urgent action shall be coloured red	No such devices used	N/A
	A multiple-voltage unit shall be marked to indicate the particular voltage for which it is set when shipped from the factory. The marking is allowed to be in the form of a paper tag or any other nonpermanent material.	The EUT is not intended to connect to multiple-voltage and there is no voltage setting device	N/A
	A unit with d.c. terminals shall be plainly marked indicating the polarity of the connections, with:	See below	P
	- the sign “+” for positive and “-”, for negative; or	The “+” and “-” marking were provided adjacent to the DC input terminals	P
	- a pictorial representation illustrating the proper polarity where the correct polarity can be unambiguously determined from the representation	No pictorial representation illustration used	N/A
5.1.6.1/RD	Protective Conductor Terminals	See below	P





URS PRODUCTS AND TESTING PRIVATE LIMITED

A-29, Sector-5, Noida-201301
 T +91 (120) 4516264-65 F +91 (120) 4750296
 E info@urs-labs.com W www.urs-labs.com
 CIN NO U21014UP1987PTC008956



Report No- SC25SPI00626_1

IS 16221 (Part 2) : 2015/ IEC 62109-2 : 2011

Page 29 of 89

Dated : 17/04/2025

Clause	Requirement + Test	Result - Remark	Verdict
	The means of connection for the protective earthing conductor shall be marked with:	See below	P
	- symbol 7 of Annex C; or	The symbol 7 of Annex C was marked adjacent to the PE terminal	P
	- the letters "PE"; or	Symbol 7 of Annex C was used	N/A
	- the colour coding green-yellow	Complies	P
5.1.7/RD	Switches and circuit-breakers	See below	N/A
	The on and off-positions of switches and circuits breakers shall be clearly marked. If a push-button switch is used as the power switch, symbols 10 and 16 of Annex C may be used to indicate the on position, or symbols 11 and 17 to indicate the off position, with the pair of symbols (10 and 16, or 11 and 17) close together.	No such Switch used	N/A
5.1.8/RD	Class II Equipment	Class I equipment	N/A
	Equipment using Class II protective means throughout shall be marked with symbol 12 of Annex C. Equipment which is only partially protected by DOUBLE INSULATION or REINFORCED INSULATION shall not bear symbol 12 of Table Annex C	See above cl. no. 5.1.8	N/A
	Where such equipment has provision for the connection of an earthing conductor for functional reasons (see 7.3.6.4) it shall be marked with symbol 6 of Annex C	See above cl. no. 5.1.8	N/A
5.1.9/RD	Terminal boxes for External Connections N	See below	P
	Where required by note 1 of Table 2 as a result of high temperatures of terminals or parts in the wiring compartment, there shall be a marking, visible beside the terminal before connection, of either:	Complies	P
	a) the minimum temperature Rating and size of the cable to be connected to the TERMINALS; or	See below b)	N/A
	b) a marking to warn the installer to consult the installation instruction. Symbol 9 of Table D-1 is an acceptable marking	Symbol 9 marked on label	P
5.2	Warning markings	See below	P
5.2.1/RD	Visibility and legibility requirements for warning markings	Warning markings are be Visible and legible.	P
	Warning markings shall be legible, and shall have minimum dimensions as follows:	See below	P
	- Printed symbols shall be at least 2,75 mm high	Complies	P
	- Printed text characters shall be at least 1.5 mm high and shall contrast in colour with the background	Complies	P
	- Symbols or text that are moulded, stamped or engraved in a material shall have a character height of at least 2,0 mm, and if not contrasting in colour from the background, shall have a depth or raised height of at least 0,5 mm	No such symbols.	N/A





URS PRODUCTS AND TESTING PRIVATE LIMITED

A-29, Sector-5, Noida-201301
T +91 (120) 4516264-65 F +91 (120) 4750296
E info@urs-labs.com W www.urs-labs.com
CIN NO U21014UP1987PTC008956



Report No- SC25SPI00626_1

IS 16221 (Part 2) : 2015/ IEC 62109-2 : 2011

Page 30 of 89

Dated : 17/04/2025

Clause	Requirement + Test	Result - Remark	Verdict
	If it is necessary to refer to the instruction manual to preserve the protection afforded by the equipment, the equipment shall be marked with symbol 9 of Annex C	The manual provide necessary information for the warning marking	P
	Symbol 9 of Annex C is not required to be used adjacent to symbols that are explained in the manual	All symbols are explained in the manual	P
5.2.2	Content for warning markings	See below	P
5.2.2.1/RD	Ungrounded heat sinks and similar parts	Grounded heatsink and metal enclosure	N/A
	An ungrounded heat sink or other part that may be mistaken for a grounded part and involves a risk of electric shock in accordance with 7.3 shall be marked with symbol 13 of Annex C, or equivalent. The marking may be on or adjacent to the heat sink and shall be clearly visible when the PCE is disassembled to the extent that a risk of contact with the heat sink exists.	See above cl. no. 5.2.2.1	N/A
5.2.2.2/RD	Hot Surfaces	See below	P
	A part of the PCE that exceeds the temperature limits specified in 4.3.2 shall be marked with symbol 14 of Annex C or equivalent.	The symbol 14 of Annex C provided on the warning label	P
5.2.2.3/RD	Coolant	No coolant contained within the equipment	N/A
	A unit containing coolant that exceeds 70 °C shall be legibly marked externally where readily visible after installation with symbol 15 of Annex C. The documentation shall provide a warning regarding the risk of burns from hot coolant, and either	See above cl. no. 5.2.2.3	N/A
	a) statement that coolant system servicing is to be done only by SERVICE PERSONNEL, or	See above cl. no. 5.2.2.3	N/A
	b) instructions for safe venting, draining, or otherwise working on the cooling system, if these operations can be performed without OPERATOR access to HAZARDS internal to the equipment	See above cl. no. 5.2.2.3	N/A
5.2.2.4/RD	Stored energy	See below	P
	Where required by 7.3.9.2 or 7.4.2 the PCE shall be marked with Symbol 21 of Annex C and the time to discharge capacitors to safe voltage and energy levels shall accompany the symbol.	Symbol 21 of annex C and “ 10min ” were provided on the label	P
5.2.2.5/RD	Motor guarding	No such devices	N/A
	Where required by 8.2 a marking shall be provided where it is visible to service personnel before removal of a guard, warning of the hazard and giving instructions for safe servicing (for example disconnection of the source before removing the guard).	See above	N/A
5.2.2.6	Inverters for closed electrical operating areas	Not located in closed electrical operating area	N/A





URS PRODUCTS AND TESTING PRIVATE LIMITED

A-29, Sector-5, Noida-201301
 T +91 (120) 4516264-65 F +91 (120) 4750296
 E info@urs-labs.com W www.urs-labs.com
 CIN NO U21014UP1987PTC008956



Report No- SC25SPI00626_1

IS 16221 (Part 2) : 2015/ IEC 62109-2 : 2011

Page 31 of 89

Dated : 17/04/2025

Clause	Requirement + Test	Result - Remark	Verdict
	Where required by 4.8.3.6, an inverter not provided with full protection against shock hazard on the PV array shall be marked with a warning that the inverter is only for use in a closed electrical operating area, and referring to the installation instructions.	See above cl. no. 5.2.2.6	N/A
5.2.3/RD	Sonic hazard markings and instructions	No sonic hazard	N/A
	If required by 10.2.1 a PCE shall:	See above cl. no. 5.2.3	N/A
	a) be marked to warn the operator of the sonic pressure hazard; o	See above cl. no. 5.2.3	N/A
	b) be provided with installation instructions that specify how the installer can ensure that the sound pressure level from equipment at its point of use after installation, will not reach a value, which could cause a hazard. These instructions shall include the measured sound pressure level, and shall identify readily available and practicable protective materials or measures which may be used.	User manual provided that noise emission less than 80dB	N/A
5.2.4/RD	Equipment with multiple sources of supply	No multiple source of supply used	N/A
	A PCE with connections for multiple energy sources shall be marked with symbol 13 of Annex C and the manual shall contain the information required in 5.3.4	See above cl. no. 5.2.4	N/A
	The symbol shall be located on the outside of the unit or shall be prominently visible behind any cover giving access to hazardous parts.	See above cl. no. 5.2.4	N/A
5.2.5/RD	Excessive touch current	See below	P
	Where required by 7.3.6.3.7 the PCE shall be marked with symbol 15 of Annex C. See also 5.3.2 for information to be provided in the installation manual.	Symbol 15 of Annex C Provided on the marking plate	P
5.3	Documentation	See below	P
5.3.1/RD	General	All related information's Provided in the user's manual.	P
	The documentation provided with the PCE shall provide the information needed for the safe operation, installation, and (where applicable) maintenance of the equipment. The documentation shall include the items required in 5.3.2 through 5.3.4, and the following:	See above cl. no. 5.3.1	P
	a) explanations of equipment makings, including symbols used	See above cl. no. 5.3.1	P
	b) location and function of terminals and controls	See above cl. no. 5.3.1	P
	c) all ratings or specifications that are necessary to safely install and operate the PCE, including the following environmental ratings along with an explanation of their meaning and any resulting installation requirements:	See above cl. no. 5.3.1	P





URS PRODUCTS AND TESTING PRIVATE LIMITED

A-29, Sector-5, Noida-201301
T +91 (120) 4516264-65 F +91 (120) 4750296
E info@urs-labs.com W www.urs-labs.com
CIN NO U21014UP1987PTC008956



Report No- SC25SPI00626_1

IS 16221 (Part 2) : 2015/ IEC 62109-2 : 2011

Page 32 of 89

Dated : 17/04/2025

Clause	Requirement + Test	Result - Remark	Verdict
	- ENVIRONMENTAL CATEGORY as per 6.1	Outdoor used	P
	- WET LOCATIONS classification for the intended external environment as per 6.1	Yes	P
	- POLLUTION DEGREE classification for the intended external environment as per 6.2	PD3	P
hh	- INGRESS PROTECTION rating as per 6.3	IP65	P
	- Ambient temperature and relative humidity ratings	(-)25°C-(+)60°C, (0%-100%)	P
	- MAXIMUM altitude rating	2000m	P
	- OVERVOLTAGE CATEGORY assigned to each input and output port as per 7.3.7.1.2, accompanied by guidance regarding how to ensure that the installation complies with the required overvoltage categories;	PV side (OVCI), AC side (OVCIII)	P
	d) a warning that when the photovoltaic array is exposed to light, it supplies a d.c. voltage to the PCE	Considered	P
5.3.1.1/RD	Language	Instructions related to safety provided in english.	P
	Instructions related to safety shall be in a language that is acceptable in the country where the equipment is to be installed.	See above cl. No. 5.3.1.1	P
5.3.1.2/RD	Format	See below	P
	In general, the documentation must be provided in printed form and is to be delivered with the equipment.	Hardcopy provided with the equipment	P
	For equipment which requires the use of a computer for both installation and operation, documentation may be provided in electronic format without accompanying printed format.	Also provided in electronic format	P
5.3.2/RD	Information related to installation	All below related information's Provided in the user's manual.	P
	The documentation shall include installation and where applicable, specific commissioning instructions and, if necessary for safety, warnings against hazards which could arise during installation or commissioning of the equipment. The information provided shall include:	See above cl. no. 5.3.2	P
	a) assembly, location, and mounting requirements:	See above cl. no. 5.3.2	P
	b) ratings and means of connection to each source of supply and any requirements related to wiring and external controls, colour coding of leads, disconnection means, or overcurrent protection needed, including instructions that the installation position shall not prevent access to the disconnection means;	See above cl. no. 5.3.2	P
	c) ratings and means of connection of any outputs from the PCE, and any requirements related to wiring and external controls, colour coding of leads, or overcurrent protection needed;	See above cl. no. 5.3.2	P





URS PRODUCTS AND TESTING PRIVATE LIMITED

A-29, Sector-5, Noida-201301
 T +91 (120) 4516264-65 F +91 (120) 4750296
 E info@urs-labs.com W www.urs-labs.com
 CIN NO U21014UP1987PTC008956



Report No- SC25SPI00626_1

IS 16221 (Part 2) : 2015/ IEC 62109-2 : 2011

Page 33 of 89

Dated : 17/04/2025

Clause	Requirement + Test	Result - Remark	Verdict
	d) explanation of the pin-out of connectors for external connections, unless the connector is used for a standard purpose (e.g. RS 232)	See above cl. no. 5.3.2	P
	e) ventilation requirements;	See above cl. no. 5.3.2	P
	f) requirements for special services, for example cooling liquid;	No special service	N/A
	g) instructions and information relating to sound pressure level if required by 10.2.1;	No sound pressure hazard	N/A
	h) where required by 14.8.1.3, instructions for the adequate ventilation of the room or location in which PCE containing vented or valveregulated batteries is located, to prevent the accumulation of hazardous gases;	No battery used	N/A
	i) tightening torque to be applied to wiring terminals;	Provided	P
	j) values of backfeed short-circuit currents available from the PCE on input and output conductors under fault conditions, if those currents exceed the max. rated current of the circuit, as per 4.4.4.6	No backfeed short-circuit current	N/A
	k) for each input to the PCE, the max value of short-circuit current available from the source, for which the PCE is designed; and	Considered	P
	l) compatibility with RCD and RCM;	Provided	P
	m) instructions for protective earthing, including the information required by 7.3.6.3.7 if a second protective earthing conductor is to be installed:	Provided	P
	n) where required by 7.3.8, the installation instructions shall include the following or equivalent wording:	RCD is build in the EUT	P
	“This product can cause a d.c. current in the external protective earthing conductor. Where a residual current-operated protective (RCD) or monitoring (RCM) device is used for protection in a case of direct or indirect contact, only an RCD or RCM of Type B is allowed on the supply side of this product.”	See above	N/A
	o) for PCE intended to charge batteries, the battery nominal voltage rating, size, and type	No battery used	N/A
	p) PV array configuration information, such as ratings, whether the array is to be grounded or floating, any external protection devices needed, etc.	Information given in user manual	P
5.3.2.1	Ratings : Subclause 5.3.2 of Part 1 requires the documentation to include ratings information for each input and output. For inverters this information shall be as in Table 33 below. Only those ratings that are applicable based on the type of inverter are required.	See below	P





URS PRODUCTS AND TESTING PRIVATE LIMITED

A-29, Sector-5, Noida-201301
 T +91 (120) 4516264-65 F +91 (120) 4750296
 E info@urs-labs.com W www.urs-labs.com
 CIN NO U21014UP1987PTC008956



Report No- SC25SPI00626_1

IS 16221 (Part 2) : 2015/ IEC 62109-2 : 2011

Page 34 of 89

Dated : 17/04/2025

Clause	Requirement + Test	Result - Remark	Verdict
	PV input quantities :	See below	P
	- Vmax PV (absolute maximum) (d.c. V)	550Vdc	P
	- PV input operating voltage range (d.c. V)	70-550Vdc	P
	- Maximum operating PV input current (d.c. A)	22A+22A	P
	- Isc PV (absolute maximum) (d.c. A)	26A	P
	- Isc PV (absolute maximum) (d.c. A)	26A	P
	- Max. inverter backfeed current to the array (a.c. or d.c. A)	0A	P
	a.c. output quantities:	See below	P
	- Voltage (nominal or range) (a.c. V)	230V	P
	- Current (maximum continuous) (a.c. A)	26.95A	P
	- Current (inrush) (a.c. A, peak and duration)	7.6 A @ 1.24 ms	P
	- Frequency (nominal or range) (Hz)	50Hz	P
	- Power (maximum continuous) (W or VA)	6200W	P
	- Power factor range	0.8Leading..1.. 0.8Lagging	P
	- Maximum output fault current (a.c. A, peak and duration or RMS)	28A @ 0.13ms	P
	- Maximum output overcurrent protection (a.c. A)	28A	P
	a.c. input quantities:	No a.c input	N/A
	- Voltage (nominal or range) (a.c. V)	See above	N/A
	- Current (maximum continuous) (a.c. A)	See above	N/A
	- Current (inrush) (a.c. A, peak and duration)	See above	N/A
	- Frequency (nominal or range) (Hz)	See above	N/A
	d.c input (other than PV) quantities:	No d.c input	N/A
	- Voltage (nominal or range) (d.c. V)	See above	N/A
	- Nominal battery voltage (d.c. V)	See above	N/A
	- Current (maximum continuous) (d.c. A)	See above	N/A
	d.c. output quantities:	No d.c output	N/A
	- Voltage (nominal or range) (d.c. V)	See above	N/A
	- Nominal battery voltage (d.c. V)	See above	N/A
	- Current (maximum continuous) (d.c. A)	See above	N/A
	Protective class (I or II or III)	Class I	P
	Ingress protection (IP) rating per part 1	IP65	P
5.3.2.2	Grid-interactive inverter setpoints	See below	N/A
	For a grid-interactive unit with field adjustable trip points, trip times, or reconnect times, the presence of such controls, the means for adjustment, the factory default values, and the limits of the ranges of adjustability shall be provided in the documentation for the PCE or in other format such as on a website. Provided solution:	No adjustable setting available. Only the factory default values	N/A





URS PRODUCTS AND TESTING PRIVATE LIMITED

A-29, Sector-5, Noida-201301
 T +91 (120) 4516264-65 F +91 (120) 4750296
 E info@urs-labs.com W www.urs-labs.com
 CIN NO U21014UP1987PTC008956



Report No- SC25SPI00626_1

IS 16221 (Part 2) : 2015/ IEC 62109-2 : 2011

Page 35 of 89

Dated : 17/04/2025

Clause	Requirement + Test	Result - Remark	Verdict
		
	The setting of field adjustable setpoints shall be accessible from the PCE	See above	N/A
5.3.2.3	Transformers and isolation	Transformerless EUT	N/A
	whether an internal isolation transformer is provided, and if so, what level of insulation (functional, basic, reinforced, or double) is provided by that transformer. The instructions shall also indicate what the resulting installation requirements are regarding such things as earthing or not earthing the array, providing external residual current detection devices, etc	See above cl. no. 5.3.2.3	N/A
	An inverter shall be provided with information to the installer regarding:	See above cl. no. 5.3.2.3	N/A
	- providing of internal isolation transformer	See above cl. no. 5.3.2.3	N/A
	- the level of insulation (functional, basic, reinforced, or double)	See above cl. no. 5.3.2.3	N/A
	The instructions shall also indicate what the resulting installation requirements are regarding:	See above cl. no. 5.3.2.3	N/A
	- earthing or not earthing the array	See above cl. no. 5.3.2.3	N/A
	- providing external residual current detection devices	See above cl. no. 5.3.2.3	N/A
	- requiring an external isolation transformer,	See above cl. no. 5.3.2.3	N/A
5.3.2.4	Transformers required but not provided	Transformer less EUT	N/A
	An inverter that requires an external isolation transformer not provided with the unit, shall be provided with instructions that specify, and for the external isolation transformer with which it is intended to be used:	See above cl. no. 5.3.2.4	N/A
	- the configuration type	See above cl. no. 5.3.2.4	N/A
	- electrical ratings	See above cl. no. 5.3.2.4	N/A
	- environmental ratings	See above cl. no. 5.3.2.4	N/A
5.3.2.5	PV modules for non-isolated inverters	See below	P
	Non-isolated inverters shall be provided with installation instructions that require PV modules that have an IEC 61730 Class A rating	Complies	P
	If the maximum AC mains operating voltage is higher than the PV array maximum system voltage then the instructions shall require PV modules that have a maximum system voltage rating based upon the AC mains voltage.	AC mains voltage not more than PV array maximum system voltage	N/A
5.3.2.6	Non-sinusoidal output waveform information	Grid connected inverter	N/A
	The instruction manual for a stand-alone inverter not complying with 4.7.5.2 shall include a warning that:	See above cl. no. 5.3.2.6	N/A
	- the waveform is not sinusoidal,	See above cl. no. 5.3.2.6	N/A
	- some loads may experience increased heating,	See above cl. no. 5.3.2.6	N/A





URS PRODUCTS AND TESTING PRIVATE LIMITED

A-29, Sector-5, Noida-201301
 T +91 (120) 4516264-65 F +91 (120) 4750296
 E info@urs-labs.com W www.urs-labs.com
 CIN NO U21014UP1987PTC008956



Report No- SC25SPI00626_1

IS 16221 (Part 2) : 2015/ IEC 62109-2 : 2011

Page 36 of 89

Dated : 17/04/2025

Clause	Requirement + Test	Result - Remark	Verdict
	- the user should consult the manufacturers of the intended load equipment before operating that load with the inverter	See above cl. no. 5.3.2.6	N/A
	The inverter manufacturer shall provide information regarding:	See above cl. no. 5.3.2.6	N/A
	- what types of loads may experience increased heating	See above cl. no. 5.3.2.6	N/A
	- recommendations for maximum operating times with such loads	See above cl. no. 5.3.2.6	N/A
	The inverter manufacturer shall specify for the waveforms as determined by the testing in 4.7.5.3.2 through 4.7.5.3.4.:	See above cl. no. 5.3.2.6	N/A
	- THD	See above cl. no. 5.3.2.6	N/A
	- slope	See above cl. no. 5.3.2.6	N/A
	- peak voltage	See above cl. no. 5.3.2.6	N/A
5.3.2.7	Systems located in closed electrical operating areas	Not located in the closed electrical operating area	N/A
	Where required by 4.8.3.6, an inverter not provided with full protection against shock hazard on the PV array shall be provided with installation instructions:	See above cl. no. 5.3.2.7	N/A
	- requiring that the inverter and the array must be installed in closed electrical operating areas	See above cl. no. 5.3.2.7	N/A
	- indicating which forms of shock hazard protection are and are not provided integral to the inverter (for example the RCD, isolation transformer complying with the 30 mA touch current limit, or residual current monitoring for sudden changes)	See above cl. no. 5.3.2.7	N/A
5.3.2.8	Stand-alone inverter output circuit bonding	Grid connected inverter	N/A
	Where required by 7.3.10, the documentation for an inverter shall include the following:	See above cl. no. 5.3.2.8	N/A
	- if output circuit bonding is required but is not provided integral to the inverter, the required means shall be described in the installation instructions, including which conductor is to be bonded and the required current carrying capability or cross-section of the bonding means;	See above cl. no. 5.3.2.8	N/A
	- if the output circuit is intended to be floating, the documentation for the inverter shall indicate that the output is floating.	See above cl. no. 5.3.2.8	N/A
5.3.2.9	Protection by application of RCD's	See below	N/A
	Where the requirement for additional protection in 4.8.3.1 is met by requiring an RCD that is not provided integral to the inverter, as allowed by 4.8.3.4, the installation instructions shall state the need for the RCD.,	The RCD protection is integrated with inverter	N/A
	and shall specify its rating, type, and required circuit location	The RCD protection is integrated with inverter	N/A
5.3.2.10	Remote indication of faults	See below	P

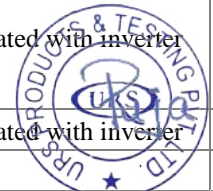



URS PRODUCTS AND TESTING PRIVATE LIMITED

A-29, Sector-5, Noida-201301
 T +91 (120) 4516264-65 F +91 (120) 4750296
 E info@urs-labs.com W www.urs-labs.com
 CIN NO U21014UP1987PTC008956



Report No- SC25SPI00626_1

IS 16221 (Part 2) : 2015/ IEC 62109-2 : 2011

Page 37 of 89

Dated : 17/04/2025

Clause	Requirement + Test	Result - Remark	Verdict
	The installation instructions shall include an explanation of how to properly make connections to (where applicable), and use, the electrical or electronic fault indicatio	RS485 connectivity provided	P
5.3.2.11	External array insulation resistance measurement and response	Clause 4.8.2.1 complies	N/A
	The installation instructions for an inverter for use with ungrounded arrays that does not incorporate all the aspects of the insulation resistance measurement and response requirements in 4.8.2.1, must include:	EUT incorporates array insulation resistance measurement	N/A
	- for isolated inverters: an explanation of what aspects of array insulation resistance measurement and response are not provided, and	See above cl. no. 5.3.2.11	N/A
	- an instruction to consult local regulations to determine if any additional functions are required or not;	See above cl. no. 5.3.2.11	N/A
	- for non-isolated inverters: an explanation of what external equipment must be provided in the system, and	See above cl. no. 5.3.2.11	N/A
	- what the setpoints and response implemented by that equipment must be, and:	See above cl. no. 5.3.2.11	N/A
	- how that equipment is to be interfaced with the rest of the system.	See above cl. no. 5.3.2.11	N/A
5.3.2.12	Array functional grounding information	No functional grounding	N/A
	Where approach a) of 4.8.2.2 is used, the installation instructions for the inverter shall include all of the following:	See above cl. no. 5.3.2.12	N/A
	a) the value of the total resistance between the PV circuit and ground integral to the inverter	See above cl. no. 5.3.2.12	N/A
	b) the minimum array insulation resistance to ground that system designer or installer must meet when selecting the PV panel and system design, based on the minimum value that the design of the PV functional grounding in the inverter was based on	See above cl. no. 5.3.2.12	N/A
	c) the minimum value of the total resistance $R = V_{MAX} / PV/30 \text{ mA}$ that the system must meet, with an explanation of how to calculate the total	See above cl. no. 5.3.2.12	N/A
	d) a warning that there is a risk of shock hazard if the total minimum resistance requirement is not met.	See above cl. no. 5.3.2.12	N/A
5.3.2.13	Stand-alone inverters for dedicated loads	Grid connected inverter	N/A
	Where the approach of 4.7.5.5 is used, the installation instructions for the inverter shall include a warning that the inverter is only to be used with the dedicated load for which it was evaluated, and	See above cl. no. 5.3.2.13	N/A
	shall specify the dedicated load.	See above cl. no. 5.3.2.13	N/A





URS PRODUCTS AND TESTING PRIVATE LIMITED

A-29, Sector-5, Noida-201301
 T +91 (120) 4516264-65 F +91 (120) 4750296
 E info@urs-labs.com W www.urs-labs.com
 CIN NO U21014UP1987PTC008956



Report No- SC25SPI00626_1

IS 16221 (Part 2) : 2015/ IEC 62109-2 : 2011

Page 38 of 89

Dated : 17/04/2025

Clause	Requirement + Test	Result - Remark	Verdict
5.3.2.14	Identification of firmware version(s)	The firmware version is displayed on LCD display	P
	An inverter utilizing firmware for any protective functions shall provide means to identify the firmware version.	See above cl. no. 5.3.2.14	P
	This can be a marking, but the information can also be provided by a display panel, communications port or any other type of user interface.....	See above cl. no. 5.3.2.14	P
6	Environmental requirements and conditions	See below	P
6.1/RD	Environmental categories and minimum environmental conditions	See below	P
6.1.1/RD	Outdoor	EUT is for outdoor use	P
6.1.2/RD	Indoor, unconditioned	EUT is for outdoor use	N/A
6.1.3/RD	Indoor, conditioned	EUT is for outdoor use	N/A
6.2/RD	Pollution degree	PD3	P
6.3/RD	Ingress Protection	IP65	P
6.4/RD	UV exposure	Certified connector used outside the enclosure	P
6.5/RD	Temperature and humidity	(-25°C to 60°C), (0%-100%)	P
7	Protection against electric shock and energy hazards	See below	P
7.1/RD	General	Both normal and single fault condition considered	P
7.2/RD	Fault conditions	See below	P
7.3	Protection against electric shock	See below	P
7.3.1/RD	General	See cl. no. 7.3.2.1	P
7.3.2/RD	Decisive voltage classification	See below	P
7.3.2.1/RD	Use of decisive voltage class (DVC)	Working voltage and protective measures are considered.	P
7.3.2.2/RD	Limits of DVC (according table 6)	Considered	P
7.3.2.3/RD	Short-terms limits of accessible voltages under fault conditions	Voltage not exceeding at DVC under fault	N/A
7.3.2.4/RD	Requirements for protection (according table 7)	Complies	P
7.3.2.5/RD	7.3.2.5/RD Connection to PELV and SELV circuits	The external signal communication interface are considered as SELV	P
7.3.2.6/RD	Working voltage and DVC	See below	P
7.3.2.6.1/RD	General	Considered	P
7.3.2.6.2/RD	AC working voltage (see Figure 2)	Considered	P
7.3.2.6.3/RD	DC working voltage (see Figure 3)	Considered	P
7.3.2.6.4/RD	Pulsating working voltage (see Figure 4)	Not considered	N/A
7.3.3/RD	Protective separation	See below	P
	Protective separation shall be achieved by:	See below	P





URS PRODUCTS AND TESTING PRIVATE LIMITED

A-29, Sector-5, Noida-201301
 T +91 (120) 4516264-65 F +91 (120) 4750296
 E info@urs-labs.com W www.urs-labs.com
 CIN NO U21014UP1987PTC008956



Report No- SC25SPI00626_1

IS 16221 (Part 2) : 2015/ IEC 62109-2 : 2011

Page 39 of 89

Dated : 17/04/2025

Clause	Requirement + Test	Result - Remark	Verdict
	- double or reinforced insulation, or	Double or reinforced insulation was provided	P
	- protective screening, i.e. by a conductive screen connected to earth by protective bonding in the PCE, or connected to the protective earth conductor itself, whereby the screen is separated from live parts by at least basic insulation, or	All accessible metal parts were earthed and separated from live parts by at least basic insulation	P
	- protective impedance comprising limitation of current per 7.3.5.3 and of discharged energy per 7.3.5.4, or	No such device	N/A
	- limitation of voltage according to 7.3.5.4.	No such device	N/A
	The protective separation shall be fully and effectively maintained under all conditions of intended use of the PCE	Complies	P
7.3.4/RD	Protection against direct contact	See below	P
7.3.4.1/RD	General	See below	P
	Protection against direct contact is employed to prevent persons from touching live parts that do not meet the requirements of 7.3.5 and shall be provided by one or more of the measure given in 7.3.4.2 (enclosures and barriers) and 7.3.4.3 (insulation).	Complies with the required of cl. No. 7.3.4.2 and 7.3.4.3.	P
	Open type sub-assemblies and devices do not require protective measures against direct contact but the instruction provided with the equipment must indicate that such measures must be provided in the end equipment or in the installation.	No such device	N/A
	Product intended for installation in CLOSED ELECTRICAL OPERATING AREAS, (see 3.9) need not have protective measures against direct contact, except as required by 7.3.4.2.4.	No such device	N/A
7.3.4.2/RD	Protection by means of enclosures and barriers	See below	P
	The following requirements apply where protection against contact with live parts is provided by enclosures or barriers, not by insulation in accordance with 7.3.4.3	Enclosure provided	P
7.3.4.2.1/RD	General	See below	P
	Parts of enclosures and barriers that provide protection in accordance with these requirements shall not be removable without the use of a tool (see 7.3.4.2.3).	Not removable without a tool and secured by screw.	P
	Polymeric materials used to meet these requirements shall also meet the requirements of 13.6	Certified connector used outside the enclosure and meeting the requirements of cl. 13.6.	P
7.3.4.2.2 / RD	Access probe criteria	See below	P
	Protection is considered to be achieved when the separation between the test probes and live parts, when tested as described below, is as follows:	Complies	P
	a) decisive voltage classification A, (DVC A) - the probe may touch the live parts	The communication interface is considered as DVC A and probe may touch such parts.	P

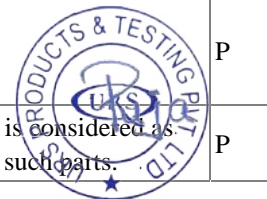



URS PRODUCTS AND TESTING PRIVATE LIMITED

A-29, Sector-5, Noida-201301
 T +91 (120) 4516264-65 F +91 (120) 4750296
 E info@urs-labs.com W www.urs-labs.com
 CIN NO U21014UP1987PTC008956



Report No- SC25SPI00626_1

IS 16221 (Part 2) : 2015/ IEC 62109-2 : 2011

Page 40 of 89

Dated : 17/04/2025

Clause	Requirement + Test	Result - Remark	Verdict
	b) decisive voltage classification B, (DVC B) - the probe must not touch bare live parts	The DVC B circuit is not accessible by probe.	P
	c) decisive voltage classification C, (DVC C) – the probe must have adequate clearance to live parts, based on the clearance for Basic insulation using the recurring peak working voltage involved,	The DVC C circuit is not accessible by probe	P
7.3.4.2.3/RD	Access probe tests	See below	P
	Compliance with 7.3.4.2.1 is checked by all of the following:	Complies	P
	a) Inspection; and	Complies	P
	b) Tests with the test finger (Figure D.1) and test pin (Figure D.2) of 0E, the results of which shall comply with the requirements of 7.3.4.2.1 a), b), and c) as applicable. Probe tests are performed on openings in the enclosures after removal of parts that can be detached or opened by an operator without the use of a tool, including fuseholders, and with operator access doors and covers open. It is permitted to leave lamps in place for this test. Connectors that can be separated by an operator without use of a tool, shall also be tested during and after disconnection. Any movable parts are to be put in the most unfavourable position.	Complies	P
	The test finger and the test pin are applied as above, without appreciable force, in every possible position, except that floor-standing equipment having a mass exceeding 40 kg is not tilted	Complies	P
	Equipment intended for building-in or rack mounting, or for incorporation in larger equipment, is tested with access to the equipment limited according to the method of mounting detailed in the installation instructions.	Not a building-in and rack mounting equipment	N/A
	c) Openings preventing the entry of the jointed test finger (Figure E-1 of 0E) during test b) above, are further tested by means of straight unjointed test finger (Figure E-3 of 0E), applied with a force of 30 N. If the unjointed finger enters, the test with the jointed finger is repeated except that the finger is applied using any necessary force up to 30 N.	Complies	P
	d) In addition to a) – c) above, top surfaces of enclosure shall be tested with the IP3X probe of IEC 60529. The test probe shall not penetrate the top surface of the enclosure when probed from the vertical direction $\pm 5^\circ$ only.	No opening in top surfaces	N/A
7.3.4.2.4/RD	Service access areas	The EUT is not allowed to remove the covers during installation and maintenance when EUT energized. Symbol 21 of Annex C are marked on EUT and explained in user manual.	N/A
7.3.4.3/RD	Protection by means of insulation of live parts	Complies	P

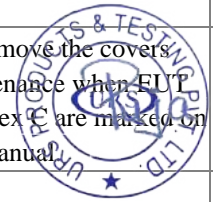



URS PRODUCTS AND TESTING PRIVATE LIMITED

A-29, Sector-5, Noida-201301
 T +91 (120) 4516264-65 F +91 (120) 4750296
 E info@urs-labs.com W www.urs-labs.com
 CIN NO U21014UP1987PTC008956



Report No- SC25SPI00626_1

IS 16221 (Part 2) : 2015/ IEC 62109-2 : 2011

Page 41 of 89

Dated : 17/04/2025

Clause	Requirement + Test	Result - Remark	Verdict
	Where the requirements of 7.3.4.2 are not met, live parts shall be provided with insulation if:	Communication ports provided with decisive voltage class A.	P
	– their working voltage is greater than the maximum limit of decisive voltage class A, or	See above	P
	– for a DVC A or B circuit, protective separation from adjacent circuit of DVC C is not provided (see note “†” under Table 7)	See above	P
7.3.5/RD	Protection in case of direct contact	See below	P
	Protection in case of direct contact is required to ensure that contact with live parts does not produce a shock hazard.	Complies	P
	The protection against direct contact according to 7.3.4 is not required if the circuit contacted is separated from other circuits according to 7.3.2.3, and:	See below	P
	– is of decisive voltage class A and complies with 7.3.5.2, or	Only DVC-A classified circuits can be touch directly	P
	– is provided with protective impedance according to 7.3.5.3, or	No such parts	N/A
	– is limited in voltage according to 7.3.5.4	No such parts	N/A
	In addition to the measures as given in 7.3.5.2 to 7.3.5.4, it shall be ensured that in the event of error or polarity reversal of connectors no voltages that exceed DVC A can be connected into a circuit with protective separation. This applies for example to plug-in-sub-assemblies or other plug-in devices which can be plugged-in without the use of a tool (key) or which are accessible without the use of a tool.	Complies	P
	Compliance is checked by visual inspection and trial insertion.	Complies	P
7.3.5.2/RD	Protection using decisive voltage class A	Complies	P
7.3.5.3/RD	Protection by means of protective impedance	No such parts	N/A
	Circuits and conductive parts do not require protection against direct contact if any connection to circuits of DVCB or DVC-C is through protective impedance, and the accessible circuit or part is otherwise provided with protective separation from circuits of DVC-B or DVC-C according 7.3.3	See above cl. no. 7.3.5.3	N/A
7.3.5.3.1/RD	Limitation of current through protective impedance	No such parts	N/A
	The current available through protective impedance to earth and between simultaneously accessible parts, measured at the accessible live parts, shall not exceed a value of 3,5 mA a.c. or 10 mA d.c. under normal and single-fault conditions.	See above cl. no. 7.3.5.3.1	N/A
7.3.5.3.2 /RD	Limitation of discharging energy through protective impedance	No such parts	N/A
	The discharging energy available between simultaneously accessible parts protected by protective impedance shall not	See above cl. no. 7.3.5.3.2	N/A





URS PRODUCTS AND TESTING PRIVATE LIMITED

A-29, Sector-5, Noida-201301
T +91 (120) 4516264-65 F +91 (120) 4750296
E info@urs-labs.com W www.urs-labs.com
CIN NO U21014UP1987PTC008956



Report No- SC25SPI00626_1

IS 16221 (Part 2) : 2015/ IEC 62109-2 : 2011

Page 42 of 89

Dated : 17/04/2025

Clause	Requirement + Test	Result - Remark	Verdict
	exceed the charging voltage and capacitance limits given in Table 9, which applies to both wet and dry locations, under normal and single fault conditions. Refer to figure 8		
7.3.5.4/RD	Protection by means of limited voltages	No such parts	N/A
	That portion of a circuit that has its voltage reduced to DVC-A by a voltage divider that complies with the following requirements, and that is otherwise provided with protective separation from circuits of DVC-B or DVCC according to 7.3.3, does not require protection against direct contact.	See above cl. no. 7.3.5.4	N/A
	The voltage divider shall be designed so that under normal and single fault conditions, including faults in the voltage division circuit, the voltage across the output of the voltage divider does not exceed the limit for DVC-A.	See above cl. no. 7.3.5.4	N/A
	This type of protection shall not be used in case of protective class II or unearthed circuits, because it relies on protective earth being connected.	See above cl. no. 7.3.5.4	N/A
7.3.6/ RD	Protection against indirect contact	See below	P
7.3.6.1/ RD	General	See below	P
	Protection against indirect contact is required to prevent shock- hazardous current being accessible from conductive parts during an insulation failure. This protection shall comply with the requirements for protective class I (basic insulation plus protective earthing), class II (double or reinforced insulation) or class III (limitation of voltages)	Protective Class I	P
	That part of a PCE meets the requirements of 7.3.6.2 and 7.3.6.3 is defined as protective class I	Class I	P
	That part of a PCE meets the requirements of 7.3.6.4 is defined as protective class II.	Class I	N/A
	That part of PCE which meets the requirements of decisive voltage class A and in which no hazardous voltages are derived, is defined as protective class III. No shock hazard is present in such circuits	Class I	N/A
	Where protection against indirect contact is dependent on means provided during installation, the installation instructions shall provide details of the required means and shall indicate the associated hazards.	Information provided	P
7.3.6.2/ RD	Insulation between live parts and accessible conductive parts	See below	P
	Accessible conductive parts of equipment shall be separated from live parts by insulation meeting the requirements of Table 7 or by clearances as specified in 7.3.7.4 and creepages as specified in 7.3.7.5	Complies. See Cl. 7.3.7.4 and Cl. 7.3.7.5	P
7.3.6.3 / RD	Protective class I – Protective bonding and earthing	See below	P





URS PRODUCTS AND TESTING PRIVATE LIMITED

A-29, Sector-5, Noida-201301
 T +91 (120) 4516264-65 F +91 (120) 4750296
 E info@urs-labs.com W www.urs-labs.com
 CIN NO U21014UP1987PTC008956



Report No- SC25SPI00626_1

IS 16221 (Part 2) : 2015/ IEC 62109-2 : 2011

Page 43 of 89

Dated : 17/04/2025

Clause	Requirement + Test	Result - Remark	Verdict
7.3.6.3.1/ RD	General	See below	P
	Equipment of protective class I shall be provided with protective earthing, and with protective bonding to ensure electrical contact between accessible conductive parts and the means of connection for the external protective earthing conductor, except bonding is not required for:	External protective earthing is to be connected to terminal near AC terminal block, refer to installation manual	P
	a) accessible conductive parts that are protected by one of the measures in 7.3.5.2 to 7.3.5.4, or	DVC A circuit considered	P
	b) accessible conductive parts are separated from live parts of DVC-B or -C using double or reinforced insulation.	Communication circuit are separated from live parts used doubled or reinforced insulation	P
7.3.6.3.2/RD	Requirements for protective bonding	See below	P
	Electrical contact with the means of connection of the external protective earthing conductor shall be achieved by one or more of the following means:	See below	P
	a) through direct metallic contact;	The connection of external protective earthing conductor is direct metal contact via terminal with screw.	P
	b) through other conductive parts which are not removed when the PCE or sub-units are used as intended ;	See above a)	N/A
	c) through a dedicated protective bonding conductor;	Complies	P
	d) through other metallic components of the PCE	See above a)	N/A
	Where direct metallic contact is used and one or both of the parts involved is painted or coated, the paint or coating shall be removed in the area of contact, or reliably penetrated, to ensure metal to metal contact.	No painted and coated	N/A
	For moving or removable parts, hinges or sliding contacts designed and maintained to have a low resistance are examples of acceptable means if they comply with the requirements of 7.3.6.3.3.	No such parts	N/A
	Metal ducts of flexible or rigid construction and metallic sheaths shall not be used as protective bonding conductors, unless the device or material has been investigated as suitable for protective bonding purposes.	No such parts	N/A
7.3.6.3.3/ RD	Rating of protective bonding	See cl. no. 7.3.6.3.5	N/A
	Protective bonding shall withstand the highest thermal and dynamic stresses that can occur to the PCE item(s) concerned when they are subjected to a fault connecting live parts to accessible conductive parts. The protective bonding shall remain effective for as long as a fault to the accessible conductive parts persists or until an upstream protective device removes power from the part.	See above	N/A
	Protective bonding shall meet following requirements:	See above	N/A





URS PRODUCTS AND TESTING PRIVATE LIMITED

A-29, Sector-5, Noida-201301
 T +91 (120) 4516264-65 F +91 (120) 4750296
 E info@urs-labs.com W www.urs-labs.com
 CIN NO U21014UP1987PTC008956



Report No- SC25SPI00626_1

IS 16221 (Part 2) : 2015/ IEC 62109-2 : 2011

Page 44 of 89

Dated : 17/04/2025

Clause	Requirement + Test	Result - Remark	Verdict
	a) For PCE with an overcurrent protective device rating of 16 A or less, the impedance of the protective bonding means shall not exceed 0,1 Ω during or at the end of the test below	See above	N/A
	b) For PCE with an overcurrent protective device rating of more than 16 A, the voltage drop in the protective bonding test shall not exceed 2,5 V during or at the end of the test below.	See above	N/A
7.3.6.3.3/ RD 5	As alternative to a) and b) the protective bonding may designed according to the requirements for the external protective earthing conductor in 7.3.6.3.5, in which case no testing is required.	See above	N/A
	The impedance of protective bonding means shall be checked by passing a test current through the bond for a period of time as specified below. The test current is based on the rating of the overcurrent protection for the equipment or part of the equipment under consideration, as follows:	See above	N/A
	a) For pluggable equipment type A, the overcurrent protective device is that provided external to the equipment (for example, in the building wiring, in the mains plug or in an equipment rack);	pluggable equipment type B	N/A
	b) For pluggable equipment type B and fixed equipment, the maximum rating of the overcurrent protective device specified in the equipment installation instructions to be provided external to the equipment;	Not pluggable equipment type B	N/A
	c) For a circuit or part of the equipment for which an overcurrent protective device is provided as part of the equipment, the rating of the provided overcurrent device.	See above	N/A
7.3.6.3.3.1/RD	Test current, duration, and acceptance criteria	See cl. no. 7.3.6.3.5	N/A
	The test current, duration of the test and acceptance criteria are as follows:	See above	N/A
	The test current, duration of the test and acceptance criteria are as follows:	See above	N/A
	a) For PCE with an overcurrent protective device rating of 16 A or less, the test current is 200% of the overcurrent protective device rating, but not less than 32 A, applied for 120s. The impedance of the protective bonding means during and at the end of the test shall not exceed 0,1 Ω .	See above	N/A
	b) For PCE with an overcurrent protective device rating of more than 16 A, the test current is 200% of the overcurrent protective device rating and the duration of the test is as shown in Table 10 below. The voltage drop in the protective bonding means, during and at the end of the test, shall not exceed 2,5 V.	See above	N/A





URS PRODUCTS AND TESTING PRIVATE LIMITED

A-29, Sector-5, Noida-201301
 T +91 (120) 4516264-65 F +91 (120) 4750296
 E info@urs-labs.com W www.urs-labs.com
 CIN NO U21014UP1987PTC008956



Report No- SC25SPI00626_1

IS 16221 (Part 2) : 2015/ IEC 62109-2 : 2011

Page 45 of 89

Dated : 17/04/2025

Clause	Requirement + Test	Result - Remark	Verdict
	c) During and after the test, there shall be no melting, loosening, or other damage that would impair the effectiveness of the protective bonding means.	See above	N/A
	The test current is derived from an a.c or d.c supply source, the output of which is not earthed.	See above	N/A
	As an alternative to Table 10, where the timecurrent characteristic of the overcurrent protective device that limits the fault current in the protective bonding means is known because the device is either provided in the equipment or fully specified in the installation instructions, the test duration may be based on that specific device's time-current characteristic,. The tests are conducted for a duration corresponding to the 200% current value on the time-current characteristic	See above	N/A
7.3.6.3.4/RD	Protective bonding impedance (routine test)	See above	N/A
	If the continuity of the protective bonding is achieved at any point by a single means only (for example a single conductor or single fastener), or if the PCE is assembled at the installation location, then the impedance of the protective bonding shall also be tested as a routine test. The test shall be as in 7.3.6.3.3, except for the following:	See above	N/A
	- the test current may be reduced to any convenient value greater than 10 A sufficient to allow measurement or calculation of the impedance of the protective bonding means:	See above	N/A
	- the test duration may be reduced to no less than 2 s	See above	N/A
	For equipment subject to the type test in 7.3.6.3.3.1a), the impedance during the routine test shall not exceed 0,1Ω.	See above	N/A
7.3.6.3.4/RD 5	For equipment subject to the type test in 7.3.6.3.3.1b) the impedance during the routine test shall not exceed 2,5 V divided by the test current required by 7.3.6.3.3.1b).	See above	N/A
7.3.6.3.5/ RD	External protective earthing conductor	See below	P
	A protective earthing conductor shall be connected at all times when power is supplied to PCE of protective class I. Unless local wiring regulations state otherwise, the protective earthing conductor cross-sectional area shall be determined from Table 11 or by calculation according to IEC 60364- 5-54.	Instruction regarding connection of earthing conductor provided in user manual.	P
	If the external protective earthing conductor is routed through a plug and socket or similar means of disconnection, it shall not be possible to disconnect it unless power is simultaneously removed from the part to be protected.	No such construction.	N/A
	- 2,5 mm ² if mechanical protection is provided;	See below	N/A
	- 4 mm ² if mechanical protection is not provided.	Refer user manual.	P





URS PRODUCTS AND TESTING PRIVATE LIMITED

A-29, Sector-5, Noida-201301
 T +91 (120) 4516264-65 F +91 (120) 4750296
 E info@urs-labs.com W www.urs-labs.com
 CIN NO U21014UP1987PTC008956



Report No- SC25SPI00626_1

IS 16221 (Part 2) : 2015/ IEC 62109-2 : 2011

Page 46 of 89

Dated : 17/04/2025

Clause	Requirement + Test	Result - Remark	Verdict
	For cord-connected equipment, provisions shall be made so that the external protective earthing conductor in the cord shall, in the case of failure of the strain-relief mechanism, be the last conductor to be interrupted	Not a cord-connected equipment	N/A
7.3.6.3.6/ RD	Means of connection for the external protective earthing conductor	External protective earthing conductor connected to enclosure body	P
7.3.6.3.6.1 / RD	General	Properly connected	P
	The means of connection for the protective earthing conductor shall be permanently marked with:	See below	P
	- symbol 7 of Annex C; or	Earthing symbol marked “ ”	P
	- the colour coding green-yellow	See above	N/A
	Marking shall not be done on easily changeable parts such as screws.	Complies	P
7.3.6.3.7/ RD	Touch current in case of failure of the protective earthing conductor	See below	P
	For pluggable equipment type A, the touch current measured in accordance with 7.5.4 shall not exceed 3,5 mA a.c. or mA d.c.	Not a pluggable equipment type A	P
	For all other PCE, one or more of the following measure shall be applied, unless the touch current measured in accordance with 7.5.4 using the test network of IEC 60990 test figure 4 shall not exceed 3,5 mA a.c. or 10 mA d.c.	Not exceeding the limit of 3.5mA ac. (See appended table 7.3.6.3.7)	P
	a) Permanently connected wiring, and:	See above	N/A
	- a cross-section of the protective earthing conductor of at least 10 mm ² Cu or 16 mm ² Al; or	See above	N/A
	- automatic disconnection of the supply in case of discontinuity of the protective earthing conductor; or	See above	N/A
	- provision of an additional terminal for a second protective earthing conductor of the same crosssectional area as the original protective earthing conductor and installation instruction requiring a second protective earthing conductor to be installed or	See above	N/A
	b) Connection with an industrial connector according to IEC 60309 and a minimum protective earthing conductor cross-section of 2,5 mm ² as part of a multi-conductor power cable. Adequate strain relief shall be provided.	See above	N/A
7.3.6.4/ RD	Protective Class II – Double or Reinforced Insulation	Protective Class I	N/A
	Equipment or parts of equipment designed for protective class II shall have insulation between live parts and accessible surfaces in accordance with 7.3.4.3. The following requirements also apply:	No such application	N/A





URS PRODUCTS AND TESTING PRIVATE LIMITED

A-29, Sector-5, Noida-201301
 T +91 (120) 4516264-65 F +91 (120) 4750296
 E info@urs-labs.com W www.urs-labs.com
 CIN NO U21014UP1987PTC008956



Report No- SC25SPI00626_1

IS 16221 (Part 2) : 2015/ IEC 62109-2 : 2011

Page 47 of 89

Dated : 17/04/2025

Clause	Requirement + Test	Result - Remark	Verdict
	- Equipment designed to protective class II shall not have means of connection for the external protective earthing conductor. However this does not apply if the external protective earthing conductor is passed through the equipment to equipment series-connected beyond it. In the latter event, the external protective earthing conductor and its means for connection shall be insulated with basic insulation from the accessible surface of the equipment and from circuits that employ protective separation, extra-low voltage, protective impedance and limited discharging energy, according to 7.3.5. This basic insulation shall correspond to the rated voltage of the seriesconnected equipment;	No such application	N/A
	- metal-encased equipment of protective class II may have provision on its enclosure for the connection of an equipotential bonding conductor;	No such application	N/A
	- equipment of protective class II may have provision for the connection of an earthing conductor for functional reasons or for damping of overvoltages; it shall, however, be insulated as though it is a live part;	No such application	N/A
	- equipment employing protective class II shall be marked according to 5.1.8.	No such application	N/A
7.3.7/RD	Insulation Including Clearance and Creepage Distance	See below	P
7.3.7.1/RD	General	Considered	P
	Insulation shall be selected after consideration of the following influences:	Considered	P
	pollution degree	PD3	P
	overvoltage category	The mains circuit: III, PV circuit : II	P
	supply earthing system	For TN system only.	P
	insulation voltage	insulation voltage Considered	P
	location of insulation	Considered	P
	type of insulation	Considered	P
	Compliance of insulation, creepage distances, and clearance distances, shall be verified by measurement or visual inspection, and the tests of 7.5.	Considered	P
7.3.7.1.3/RD	Supply earthing systems	See below	P
	Three basic types of earthing system are described in IEC 60364-1. They are:	See below	P
	TN system: has one point directly earthed, the accessible conductive parts of the installation being connected to that point by protective conductors. Three types of TN systems, TN-C, TN-S and TN-C-S, are defined according to the arrangement of the neutral and protective conductor.	For TN system only	P





URS PRODUCTS AND TESTING PRIVATE LIMITED

A-29, Sector-5, Noida-201301
 T +91 (120) 4516264-65 F +91 (120) 4750296
 E info@urs-labs.com W www.urs-labs.com
 CIN NO U21014UP1987PTC008956



Report No- SC25SPI00626_1

IS 16221 (Part 2) : 2015/ IEC 62109-2 : 2011

Page 48 of 89

Dated : 17/04/2025

Clause	Requirement + Test	Result - Remark	Verdict
	TT system: has one point directly earthed, the accessible conductive parts of the installation being connected to earth electrodes electrically independent of the earth electrodes of the power system;	See above	N/A
	IT system: has all live parts isolated from earth or one point connected to earth through an impedance, the accessible conductive parts of the installation being earthed independently or collectively to the earthing system.	See above	N/A
7.3.7.1.4 /RD	Insulation voltages	See appended table 7.5/RD	P
7.3.7.2/RD	Insulation between a circuit and its surroundings	See below	P
7.3.7.2.1 / RD	General	Considered	P
7.3.7.2.2 / RD	Circuits connected directly to the mains	Clearances and solid insulation required according to the impulse voltage, temporary overvoltage, or working voltage, whichever gives the most severe requirement.	P
7.3.7.2.3/ RD	Circuits other than mains circuits	Clearances and solid insulation required according to the impulse voltage and recurring peak voltage.	P
7.3.7.2.4/RD	Insulation between circuits	Clearances and solid insulation according to the higher impulse voltages. Creepage according to the r.m.s. working voltage	P
7.3.7.3/ RD	Functional insulating	Considered	P
7.3.7.4/RD	Clearance distances	See appended table 7.3.7.4	P
7.3.7.4.1/RD	Determination	Altitude: 4000m.	P
7.3.7.4.2 /RD	Electric field homogeneity	Not considered	N/A
7.3.7.4.3/RD	Clearance to conductive enclosures	Refer to subclause 7.3.7.4.1 and 13.7.	P
7.3.7.5/RD	Creepage distances	See appended table 7.3.7.5	P
7.3.7.5.1 /RD	General	See below	P
7.3.7.5.2 / RD	Voltage	The max. voltage: (240V)/550Vdc	P
7.3.7.5.3/ RD	Materials	Insulating material group IIIb	P
7.3.7.6/ RD	Coating	No such parts	N/A
7.3.7.7/ RD	PWB spacings for functional insulating	Certified PCB used	P
7.3.7.8/ RD	Solid insulating	Certified component used	P
7.3.7.8.1/ RD	General	See above cl. no. 7.3.7.8	P
7.3.7.8.2/ RD	Requirements for electrical withstand capability of solid insulation	See below	P
7.3.7.8.2.1/ RD	Basic, supplemental, reinforced, and double insulation	Passed the impulse withstand voltage and a.c or d.c. voltage tests.(See appended table 7.5.1, 7.5.2 & 7.5.3)	P
7.3.7.8.2.2/ RD	Functional insulation	Complies	P
7.3.7.8.3/ RD	Thin sheet or tape material	See below	P





URS PRODUCTS AND TESTING PRIVATE LIMITED

A-29, Sector-5, Noida-201301
 T +91 (120) 4516264-65 F +91 (120) 4750296
 E info@urs-labs.com W www.urs-labs.com
 CIN NO U21014UP1987PTC008956



Report No- SC25SPI00626_1

IS 16221 (Part 2) : 2015/ IEC 62109-2 : 2011

Page 49 of 89

Dated : 17/04/2025

Clause	Requirement + Test	Result - Remark	Verdict
7.3.7.8.3.1/RD	General	The transformer primary and secondary windings were separated by thin insulation sheet	P
7.3.7.8.3.2/ RD	Material thickness not less than 0,2 mm	See appended table 7.3.7	P
7.3.7.8.3.3/ RD	Material thickness less than 0,2 mm	Not used.	N/A
7.3.7.8.3.4/ RD	Compliance	See appended table 7.5.1, 7.5.2 & 7.5.3	P
7.3.7.8.4/ RD	Printed wiring boards	Certified PCB used	P
7.3.7.8.4.1/ RD	General	See above cl. no. 7.3.7.8.4	P
7.3.7.8.4.2/ RD	Use of coating materials	No coating material used.	N/A
7.3.7.8.5/ RD	Wound components	No such wound components.	N/A
7.3.7.8.6/ RD	Potting materials	No potting material used	N/A
7.3.7.9/ RD	Insulation requirements above 30 kHz	Considered	P
7.3.8/ RD	Residual Current-operated protective (RCD) or monitoring (RCM) device compatibility	The RCD is inbuilt within EUT	P
7.3.9/ RD	Protection against shock hazard due to stored energy	Considered	P
7.3.9.1/ RD	Operator access area	See below	P
	Equipment shall be so designed that there is no risk of electric shock in operator access areas from charge stored on capacitors after disconnection of the PCE.	The pins of connector cannot be touch by test finger due to design protection	P
7.3.9.2/RD	Service access areas	See below	P
	Capacitors located behind panels that are removable for servicing, installation, or disconnection shall present no risk of electric shock or energy hazard from charge stored on capacitors after disconnection of the PCE.	The symbol 21 of annex C with 10min was provided on the label.	P
7.3.10	Additional requirements for stand-alone inverters	Not a stand-alone inverter	N/A
	One circuit conductor bonded to earth to create a grounded conductor and an earthed system.	See above cl. no. 7.3.10	N/A
	The means used to bond the grounded conductor to protective earth provided within the inverter or	See above cl. no. 7.3.10	N/A
	as part of the installation	See above cl. no. 7.3.10	N/A
	If not provided integral to the inverter, the required means shall be described in the installation instructions as per 5.3.2.8.	See above cl. no. 7.3.10	N/A
	The means used to bond the grounded conductor to protective earth shall comply with the requirements for protective bonding in Part 1,	See above cl. no. 7.3.10	N/A
	If the bond can only ever carry fault currents in standalone mode, the maximum current for the bond is determined by the inverter maximum output fault current.	See above cl. no. 7.3.10	N/A
	Output circuit bonding arrangements shall ensure that in any mode of operation, the system only has the grounded circuit conductor bonded to earth in one place at a time..	See above cl. no. 7.3.10	N/A





URS PRODUCTS AND TESTING PRIVATE LIMITED

A-29, Sector-5, Noida-201301
 T +91 (120) 4516264-65 F +91 (120) 4750296
 E info@urs-labs.com W www.urs-labs.com
 CIN NO U21014UP1987PTC008956



Report No- SC25SPI00626_1

IS 16221 (Part 2) : 2015/ IEC 62109-2 : 2011

Page 50 of 89

Dated : 17/04/2025

Clause	Requirement + Test	Result - Remark	Verdict
	Switching arrangements may be used, in which case the switching device used is to be subjected to the bond impedance test along with the rest of the bonding path	See above cl. no. 7.3.10	N/A
	Inverters intended to have a circuit conductor bonded to earth shall not impose any normal current on the bond except for leakage current.	See above cl. no. 7.3.10	N/A
	Outputs that are intentionally floating with no circuit conductor bonded to ground, must not have any voltages with respect to ground that are a shock hazard in accordance with Clause 7 of Parts 1 and 2.	See above cl. no. 7.3.10	N/A
	The documentation for the inverter shall indicate that the output is floating as per 5.3.2.8.	See above cl. no. 7.3.10	N/A
7.3.11	Functionally grounded arrays	No such parts	N/A
	All PV conductors in a functionally grounded array shall be treated as being live parts with respect to protection against electric shock.	No such parts	N/A
7.4/RD	Protection against energy hazards	See below	P
7.4.1/RD	Determination of hazardous energy level	Hazardous energy level not present.	N/A
	A hazardous energy level is considered to exist if	See below	N/A
	a) The voltage is 2 V or more, and power available after 60 s exceeds 240 VA.	No such hazardous energy level exist.	N/A
	b) The stored energy in a capacitor is at a voltage. U of 2 V or more, and the stored energy. E, calculated from the following equation, exceeds 20J: $E = 0,5 CU^2$	No such hazardous energy level exist.	N/A
7.4.2/ RD	Operator Access Areas	See below	P
	Equipment shall be so designed that there is no risk of energy hazard in operator access areas from accessible circuits.	All hazardous energy parts were enclosed within earthed heat sink	P
7.4.3/ RD	Services Access Areas	The symbol 21 of annex C with 10 min was provided on the label	P
7.5/ RD	Electrical tests related to shock hazard	See below	P
7.5.1/ RD	Impulse voltage test (type test)	During the test no puncture, flashover, or spark over occurs. (See appended table 7.5)	P
7.5.2/ RD	Voltage test (dielectric strength test)	See below	P
7.5.2.1 / RD	Purpose of test	To verify the clearances and solid insulation and of assembled PCE has adequate dielectric strength to resist overvoltage's	P
7.5.2.2/ RD	Value and type of test voltage	See appended table 7.5	P
7.5.2.3/ RD	Humidity pre-conditioning	Test performed as per cl. no. 4.5	P
7.5.2.4 / RD	Performing the voltage test	See appended table 7.5	P
7.5.2.5/ RD	Duration of the a.c. or d.c. voltage test	Tested for 60s	P





URS PRODUCTS AND TESTING PRIVATE LIMITED

A-29, Sector-5, Noida-201301
 T +91 (120) 4516264-65 F +91 (120) 4750296
 E info@urs-labs.com W www.urs-labs.com
 CIN NO U21014UP1987PTC008956



Report No- SC25SPI00626_1

IS 16221 (Part 2) : 2015/ IEC 62109-2 : 2011

Page 51 of 89

Dated : 17/04/2025

Clause	Requirement + Test	Result - Remark	Verdict
7.5.2.6/ RD	Verification of the a.c. or d.c. voltage test	No electrical breakdown occurs and no abnormal current flow during the test	P
7.5.3/ RD	Partial discharge test	Certified component used	P
7.5.3/ RD	Partial discharge test	Certified component used	P
7.5.4/ RD	Touch current measurement (type test)	See below	P
	The touch current shall be measured if required by 7.3.6.3.7 and shall not be greater than 3.5 mA a.c. or 10 mA d.c. or special measures of protection as given in 7.3.6.3.7 are required.	See appended table 7.3.6.3.7	P
	For type tests on PCE for which wet locations requirements apply according to 6.1, the humidity preconditioning of 4.5 shall be performed immediately prior to the touch current test	See appended table 7.3.6.3.7	P
7.5.5/RD	Equipment with multiple sources of supply	No multiple source of supply used	N/A
8	Protection against mechanical hazards	See below	O
8.1/ RD	General	See below	P
	Operation shall not lead to a mechanical HAZARD in NORMAL CONDITION or SINGLE FAULT CONDITION. Edges, projections, corners, openings, guards, handles and the like, that are accessible to the operator shall be smooth and rounded so as not to cause injury during normal use of the equipment.	No mechanical hazards under normal and single Fault condition	P
	Conformity is checked as specified in 8.2 to 8.6	See 8.2 to 8.6	P
8.2/ RD	Moving parts	See below	P
	Moving parts shall not be able to crush, cut or pierce parts of the body of an OPERATOR likely to contact them, nor severely pinch the OPERATOR's skin. Hazardous moving parts of equipment, that is moving parts which have the potential to cause injury, shall be so arranged, enclosed or guarded as to provide adequate protection against the risk of personal injury.	No moving parts are accessible from outside	P
8.2.1/ RD	Protection of service persons	No such parts	N/A
	Protection shall be provided such that unintentional contact with hazardous moving parts is unlikely during servicing operations. If a guard over a hazardous moving part may need to be removed for servicing, the marking of symbol 15 of Table D-1 shall be applied on or near the guard.	See above cl. no. 8.2.1	N/A
8.3/ RD	Stability	The EUT for wall mounting	N/A
	Equipment and assemblies of equipment not secured to the building structure before operation shall be physically stable in NORMAL USE.	See above cl. no. 8.3	N/A
8.4/ RD	Provisions for lifting and carrying	See below	P





URS PRODUCTS AND TESTING PRIVATE LIMITED

A-29, Sector-5, Noida-201301
 T +91 (120) 4516264-65 F +91 (120) 4750296
 E info@urs-labs.com W www.urs-labs.com
 CIN NO U21014UP1987PTC008956



Report No- SC25SPI00626_1

IS 16221 (Part 2) : 2015/ IEC 62109-2 : 2011

Page 52 of 89

Dated : 17/04/2025

Clause	Requirement + Test	Result - Remark	Verdict
	If carrying handles or grips are fitted to, or supplied with, the equipment, they shall be capable of withstanding a force of four times the weight of the equipment	After the test there shall not be break loose from the equipment and there shall not be any permanent distortion, cracking or other evidence of failure	P
	Equipment or parts having a mass of 18 kg or more shall be provided with a means for lifting and carrying or directions shall be given in the manufacturer's documentation.	Refer user manual	P
8.5/ RD	Wall mounting	See below	P
	Mounting brackets on equipment intended to be mounted on a wall or ceiling shall withstand a force of four times the weight of the equipment.	No any damage after the test	P
8.6/RD	Expelled parts	See below	N/A
	Equipment shall contain or limit the energy of parts that could cause a HAZARD if expelled in the event of a fault.	No such parts	N/A
9	Protection against fire hazards	See below	P
9.1/ RD	Resistance to fire	Considered	P
	This subclause specifies requirements intended to reduce the risk of ignition and the spread of flame, both within the equipment and to the outside, by the appropriate use of materials and components and by suitable construction.	Components are verified at normal and abnormal tests	P
9.1.1/RD	Reducing the risk of ignition and spread of flame	Use of material with required flammability classes	P
	For equipment or a portion of equipment, there are two alternative methods of providing protection against ignition and spread of flame that could affect materials, wiring, wound components and electronic components such as integrated circuits, transistors, thyristors, diodes, resistors and capacitors.	Method 1 is used	P
9.1.2/RD	Conditions for a fire enclosure	See below	P
	A FIRE ENCLOSURE is required for equipment or parts of equipment for which Method 2 is not fully applied and complied with.	Fire enclosure is used	P
9.1.2.1/ RD	Parts requiring a fire enclosure	See below	P
	Except where Method 2 is used, or as permitted in 9.1.2.2, the following are considered to have a risk of ignition and, therefore, require a FIRE ENCLOSURE:	Considered	P
	- components in PRIMARY CIRCUITS	Considered	P
	- components in SECONDARY CIRCUITS supplied by power sources which exceed the limits for a LIMITED POWER SOURCE as specified in 9.2;	Considered	P
	- components in SECONDARY CIRCUITS supplied by a LIMITED POWER SOURCE as specified in 9.2, but not mounted on a material of FLAMMABILITY CLASS V-1;	No such devices	N/A





URS PRODUCTS AND TESTING PRIVATE LIMITED

A-29, Sector-5, Noida-201301
 T +91 (120) 4516264-65 F +91 (120) 4750296
 E info@urs-labs.com W www.urs-labs.com
 CIN NO U21014UP1987PTC008956



Report No- SC25SPI00626_1

IS 16221 (Part 2) : 2015/ IEC 62109-2 : 2011

Page 53 of 89

Dated : 17/04/2025

Clause	Requirement + Test	Result - Remark	Verdict
	- components within a power supply unit or assembly having a limited power output complying with the criteria for a LIMITED POWER SOURCE as specified in 9.2, including overcurrent protective devices, limiting impedances, regulating networks and wiring, up to the point where the LIMITED POWER SOURCE output criteria are met;	No such devices	N/A
	- components having unenclosed arcing parts, such as open switch and relay contacts and commutators, in a circuit at HAZARDOUS VOLTAGE or at a HAZARDOUS ENERGY LEVEL; and	No such devices	N/A
	- insulated wiring, except as permitted in 9.1.2.2	No such devices	N/A
9.1.2.2/ RD	Parts not requiring a fire enclosure	Connectors.	P
9.1.3/RD	Materials requirements for protection against fire hazard	See below	P
9.1.3.1/RD	General	See below	P
9.1.3.1/RD 1	ENCLOSURES, components and other parts shall be so constructed, or shall make use of such materials, that the propagation of fire is limited.	Metal enclosure and certified components used.	P
9.1.3.2/ RD	Materials for fire enclosures	Metal enclosure is used.	P
	If an enclosure material is not classified as specified below, a test may be performed on the final enclosure or part of the enclosure, in which case the material shall additionally be subjected to periodic SAMPLE testing.	See above cl. no. 9.1.3.2	P
9.1.3.3/ RD	Materials for components and other parts outside fire enclosures	Certified component used	P
	Except as otherwise noted below, materials for components and other parts (including MECHANICAL ENCLOSURES, ELECTRICAL ENCLOSURES and DECORATIVE PARTS); located outside FIRE ENCLOSURES, shall be of FLAMMABILITY CLASS HB.	No such parts	N/A
9.1.3.4/ RD	Materials for components and other parts inside fire enclosures	Components and materials have adequate flammability classification, V-0 class PCB used	P
9.1.3.5/ RD	Materials for air filter assemblies	No such material used	N/A
9.1.4/ RD	Openings in fire enclosures	See below	P
9.1.4.1/ RD	General	Complies	P
	For equipment that is intended to be used or installed in more than one orientation as specified in the product documentation, the following requirements apply in each orientation.	Information related to Installation provided in user manual	P
	These requirements are in addition to those in the following sections:	See below	P
	- 7.3.4, Protection against direct contact;	Refer cl 7.3.4	P
	- 7.4, Protection against energy hazards;	Refer cl 7.4	P





URS PRODUCTS AND TESTING PRIVATE LIMITED

A-29, Sector-5, Noida-201301
 T +91 (120) 4516264-65 F +91 (120) 4750296
 E info@urs-labs.com W www.urs-labs.com
 CIN NO U21014UP1987PTC008956



Report No- SC25SPI00626_1

IS 16221 (Part 2) : 2015/ IEC 62109-2 : 2011

Page 54 of 89

Dated : 17/04/2025

Clause	Requirement + Test	Result - Remark	Verdict
	13.5, Openings in enclosures	No such openings	N/A
9.1.4.2 / RD	Side openings treated as bottom openings	No side opening	N/A
9.1.4.3/ RD	Openings in the bottom of a fire enclosure	No bottom opening	N/A
	The bottom of a FIRE ENCLOSURE or individual barriers, shall provide protection against emission of flaming or molten material under all internal parts, including partially enclosed components or assemblies, for which Method 2 of 9.1.1 has not been fully applied and complied with.	See above cl. no. 9.1.4.3	N/A
9.1.4.4/ RD	Equipment for use in a CLOSED ELECTRICAL OPERATING AREA	Not intend use at this area	N/A
	The requirements of 9.1.4.3 do not apply to FIXED EQUIPMENT intended only for use in a CLOSED ELECTRICAL OPERATING AREA and to be mounted on a concrete floor or other noncombustible surface. Such equipment shall be marked as follows:	See above 9.1.4.4	N/A
	WARNING: FIRE HAZARD SUITABLE FOR MOUNTING ON CONCRETE OR OTHER NONCOMBUSTIBLE SURFACE ONLY	See above 9.1.4.4	N/A
9.1.4.5/ RD	Doors or covers in fire enclosures	No any door or covers in fire enclosure	N/A
9.1.4.6/ RD	Additional requirements for openings in transportable equipment	Not a transportable equipment	N/A
9.2/ RD	LIMITED POWER SOURCES	No limited power source used.	N/A
9.2/ RD	LIMITED POWER SOURCES	No limited power source used.	N/A
9.2.1/ RD	General	See above cl. no. 9.2	N/A
9.2.2/ RD	Limited power source tests	See above cl. no. 9.2	N/A
9.3	Short-circuit and overcurrent protection	See below	P
9.3.1/ RD	General	Considered	P
	The PCE shall not present a hazard, under shortcircuit or overcurrent conditions at any port, including phase-to-phase, phase-to-earth and phase-to-neutral, and adequate information shall be provided to allow proper selection of external wiring and external protective devices.	The short circuit and over current are protected by circuit design. When short-circuit or over current of components occurred. the EUT will shut down from grid immediately	P
9.3.2/ RD	Protection against short-circuits and over currents shall be provided for all input circuits, and for output circuits that do not comply with the requirements for limited power sources in 9.2, except for circuits in which no over current hazard is presented by short circuits and overloads.	See above cl. no. 9.3	P
9.3.3/ RD	Protective devices provided or specified shall have adequate breaking capacity to interrupt the maximum short circuit current specified for the port to which they are connected. If protection that is provided integral to the PCE for an input port is not rated for the short-circuit current of the circuit in	See above cl. no. 9.3	P





URS PRODUCTS AND TESTING PRIVATE LIMITED

A-29, Sector-5, Noida-201301
 T +91 (120) 4516264-65 F +91 (120) 4750296
 E info@urs-labs.com W www.urs-labs.com
 CIN NO U21014UP1987PTC008956



Report No- SC25SPI00626_1

IS 16221 (Part 2) : 2015/ IEC 62109-2 : 2011

Page 55 of 89

Dated : 17/04/2025

Clause	Requirement + Test	Result - Remark	Verdict
	which it is used, the installation instructions shall specify that an upstream protective device, rated for the prospective short-circuit current of that port, shall be used to provide backup protection.		
9.3.4	Inverter backfeed current onto the array	See below	P
	The backfeed current testing and documentation requirements in Part 1 apply, including but not limited to the following.	See below	P
	Inverter backfeed current onto the PV array maximum value	<0A	P
	This inverter backfeed current value shall be provided in the installation instructions regardless of the value of the current, in accordance with Table 33.	0A, Provided in user manual	P
10	Protection against sonic pressure hazards	See below	P
10.1/RD	General	See below	P
	The equipment shall provide protection against the effect of sonic pressure. Conformity tests are carried out if the equipment is likely to cause such HAZARDS.	No sonic pressure hazards.	P
10.2/ RD	Sonic pressure and Sound level	See below	P
10.2.1/ RD	Hazardous noise levels	Less than 80dB	P
11	Protection against liquid hazards	No liquid containment system used	N/A
11.1/RD	Liquid Containment, Pressure and Leakage	See above cl. no. 11	N/A
	The liquid containment system components shall be compatible with the liquid to be used.	See above cl. no. 11	N/A
	There shall be no leakage of liquid onto live parts as a result of:	See above cl. no. 11	N/A
	a) Normal operation, including condensation;	See above cl. no. 11	N/A
	b) Servicing of the equipment; or	See above cl. no. 11	N/A
	c) Inadvertent loosening or detachment of hoses or other cooling system parts over time.	See above cl. no. 11	N/A
11.2/RD	Fluid pressure and leakage	See above cl. no. 11	N/A
11.2.1/RD	Maximum pressure	See above cl. no. 11	N/A
11.2.2/RD	Leakage from parts	See above cl. no. 11	N/A
11.2.3/RD	Overpressure safety device	See above cl. no. 11	N/A
11.3/ RD	Oil and grease	See above cl. no. 11	N/A
12	Protection against Chemical Hazards	No chemical hazards	N/A
12.1/ RD	General	See above cl. no. 12	N/A
13	Physical requirements	See below	P
13.1/RD	Handles and manual controls	Complies	P
	Handles, knobs, grips, levers and the like shall be reliably fixed so that they will not work loose in normal use, if this	Complies	P





URS PRODUCTS AND TESTING PRIVATE LIMITED

A-29, Sector-5, Noida-201301
 T +91 (120) 4516264-65 F +91 (120) 4750296
 E info@urs-labs.com W www.urs-labs.com
 CIN NO U21014UP1987PTC008956



Report No- SC25SPI00626_1

IS 16221 (Part 2) : 2015/ IEC 62109-2 : 2011

Page 56 of 89

Dated : 17/04/2025

Clause	Requirement + Test	Result - Remark	Verdict
	might result in a hazard. Sealing compounds and the like, other than self-hardening resins, shall not be used to prevent loosening. If handles, knobs and the like are used to indicate the position of switches or similar components, it shall not be possible to fix them in a wrong position if this might result in hazard.		
13.1.1/ RD	Adjustable controls	No adjustable control	N/A
13.2/RD	Securing of parts	All screws locked with star washer	P
13.3/RD	Provisions for external connections	See below	P
13.3.1/ RD	General	Complies	P
13.3.2/RD	Connection to an a.c. Mains supply	An industrial AC connector used and it is detachable with tool	P
13.3.2.1/RD	General	Certified PV connector are used. Installation manual provide information for the disconnection means	P
	For safe and reliable connection to a MAINS supply, equipment shall be provided with one of the following:	See below	P
	– terminals or leads or a non-detachable power supply cord for permanent connection to the supply; or	Screw terminal for permanent connection to supply	P
	– an appliance inlet for connection of a detachable power supply cord; or	See above	N/A
	– a mains plug that is part of direct plug-in equipment as in 13.3.8	See above	N/A
13.3.2.2/ RD	Permanently connected equipment	Terminal block with junction box is used for AC connection	P
13.3.2.3/ RD	Appliance inlets	No appliance inlet used	N/A
13.3.2.4/ RD	Power supply cord	No such supply cord used	N/A
13.3.2.5/RD	Cord anchorages and strain relief	No such supply cord used	N/A
	For equipment with a non-detachable power supply cord, a cord anchorage shall be supplied such that:	See above cl. no. 13.3.2.5	N/A
	– the connecting points of the cord conductors are relieved from strain; and	See above cl. no. 13.3.2.5	N/A
	– the outer covering of the cord is protected from abrasion.	See above cl. no. 13.3.2.5	N/A
13.3.2.6/ RD	Protection against mechanical damage	See above cl. no. 13.3.2.5	N/A
13.3.3/RD	Wiring terminals for connection of external conductors	See below	P
13.3.3.1/ RD	Wiring terminals	The terminal can accommodate the conductors which specified in the user manual and the temperature rise did not exceed manufacturer's rating.	P
13.3.3.2/ RD	Screw terminals	A ring terminal washer used to each external power supply conductor	P

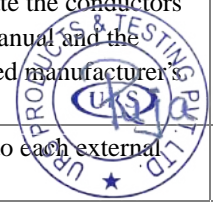



URS PRODUCTS AND TESTING PRIVATE LIMITED

A-29, Sector-5, Noida-201301
 T +91 (120) 4516264-65 F +91 (120) 4750296
 E info@urs-labs.com W www.urs-labs.com
 CIN NO U21014UP1987PTC008956



Report No- SC25SPI00626_1

IS 16221 (Part 2) : 2015/ IEC 62109-2 : 2011

Page 57 of 89

Dated : 17/04/2025

Clause	Requirement + Test	Result - Remark	Verdict
13.3.3.3/ RD	Wiring terminal sizes	Complies	P
13.3.3.4/ RD	Wiring terminal design	Terminal design with appropriate fixing hardware for conductor so that can't slip out	P
13.3.3.5/ RD	Grouping of wiring terminals	Input and output terminals located in proximity to each other.	P
13.3.3.6/ RD	Stranded wire	Not used.	N/A
13.3.4/ RD	Supply wiring space	Complies	P
13.3.5/RD	Wire bending space for wires 10 mm ² and greater	No such application	N/A
13.3.6/RD	Disconnection from supply sources	Installation manual instruct the disconnect device shall be provided before connecting AC mains and PV array	P
13.3.7/RD	Connectors, plugs and sockets	Certified PV connector used. Plug and sockets not used.	P
13.3.8/RD	Direct plug-in equipment	Not a direct plug-in equipment	N/A
13.4/RD	Internal wiring and connections	See below	P
13.4.1/RD	General	All wires were used suitably and are fixed well to prevent mechanical damaged during installation	P
13.4.2/RD	Routing	All wires were routed away from all parts which would abrade the insulation of wires	P
13.4.3/RD	Colour coding	Green/yellow wire only used for protective earthing conductor	P
13.4.4/RD	Splices and connections	All wire with core cable ends.	P
13.4.5/RD	Interconnections between parts of the PCE	Special construction of connectors to prevent from misconnection.	P
13.5/RD	Openings in enclosures	See below	P
	Openings in the top and sides of ENCLOSURES shall be so located or constructed that it is unlikely that objects will enter the openings and create hazards by contacting bare conductive parts	Complies	P
13.6/RD	Polymeric Materials	Metal enclosure used and Certified connector, DC Switch outside the enclosure.	P
13.6.1/RD	General	See above cl. no. 13.6	P
13.6.1.1/RD	Thermal index or capability	See above cl. no. 13.6	P
13.6.2/RD	Polymers serving as enclosures or barriers preventing access to hazards	See above cl. no. 13.6	N/A
13.6.2.1/RD	Stress relief test	No shrinkage or distortion observed after the test	P
13.6.3/RD	Polymers serving as solid insulation	See above cl. no. 13.6	P
13.6.3.1/RD	Resistance to arcing	See above cl. no. 13.6	P
13.6.4/RD	UV resistance	Certified PV connector used outside the enclosure	P

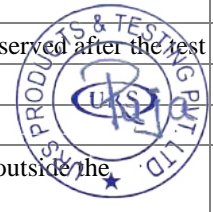



URS PRODUCTS AND TESTING PRIVATE LIMITED

A-29, Sector-5, Noida-201301
 T +91 (120) 4516264-65 F +91 (120) 4750296
 E info@urs-labs.com W www.urs-labs.com
 CIN NO U21014UP1987PTC008956



Report No- SC25SPI00626_1

IS 16221 (Part 2) : 2015/ IEC 62109-2 : 2011

Page 58 of 89

Dated : 17/04/2025

Clause	Requirement + Test	Result - Remark	Verdict
	Polymeric parts of an OUTDOOR ENCLOSURE required for compliance with this standard shall be sufficiently resistance to degradation by ultra-violet (UV) radiation	See above cl. no. 13.6.4	P
13.7/RD	Mechanical resistance to deflection, impact, or drop	See below	P
13.7.1/RD	General	Complies	P
13.7.2/RD	250-N deflection test for metal enclosures	No hazard occurred	P
13.7.3/RD	7-J impact test for polymeric enclosures	No such enclosure	N/A
13.7.4/RD	Drop test	Not a hand-held, direct-plug in and transportable equipment	N/A
13.8/RD	Thickness requirements for metal enclosures	Complies with 13.7	N/A
13.8.1/RD	General	See above cl. no. 13.8	N/A
13.8.2/RD	Cast metal	See above cl. no. 13.8	N/A
13.8.3/RD	Sheet metal	See above cl. no. 13.8	N/A
13.9	Fault indication	See below	P
	Where this Part 2 requires the inverter to indicate a fault, both of the following shall be provided:	LCD and interface connected to PC as fault indication	P
	a) a visible or audible indication, integral to the inverter, and detectable from outside the inverter, and	LCD and interface connected to PC as fault indication	P
	b) an electrical or electronic indication that can be remotely accessed and used.	LCD display shows fault indication	P
	The installation instructions shall include information regarding how to properly make connections (where applicable) and use the electrical or electronic means in b) above, in accordance with 5.3.2.10.	The instructions are specified in the manual	P
	– a non-detachable power supply cord for connection to the supply by means of a plug	See above	N/A
14	Components	See below	P
14.1/RD	General	Considered	P
	Where safety is involved, components shall be used in accordance with their specified RATINGS unless a specific exception is made. They shall conform to one of the following:	See below	P
	a) applicable safety requirements of a relevant IEC standard. Conformity with other requirements of the component standard is not required. If necessary for the application, components shall be subjected to the test of this standard, except that it is not necessary to carry out identical or equivalent tests already performed to check conformity with the component standard;	Certified component used according to their relevant safety standards. (see list of critical component)	P
	b) the requirements of this standard and, where necessary for the application, any additional applicable safety requirements	Certified component used (see list of critical component)	P





URS PRODUCTS AND TESTING PRIVATE LIMITED

A-29, Sector-5, Noida-201301
 T +91 (120) 4516264-65 F +91 (120) 4750296
 E info@urs-labs.com W www.urs-labs.com
 CIN NO U21014UP1987PTC008956



Report No- SC25SPI00626_1

IS 16221 (Part 2) : 2015/ IEC 62109-2 : 2011

Page 59 of 89

Dated : 17/04/2025

Clause	Requirement + Test	Result - Remark	Verdict
	of the relevant IEC component standard;		
	c) if there is no relevant IEC standard, the requirements of this standard;	Certified component used and also verified/tested according to this standard. (see list of critical component)	P
	d) applicable safety requirements of a non-IEC standard which are at least as high as those of the applicable IEC standard, provided that the component has been approved to the non-IEC standard by a recognized testing authority.	Certified component used which are harmonized to relevant IEC standards. (see list of critical component)	P
	Components such as optocouplers, capacitors, transformers, and relays connected across basic, supplemental, reinforced, or double insulation shall comply with the requirements applicable for the grade of insulation being bridged, and if not previously certified to the applicable component safety standard shall be subjected to the voltage test of 7.5.2 as routine test.	Certified component used (see list of critical component)	P
14.2/RD	Motor Over temperature Protection	No motor used	N/A
	Motors which, when stopped or prevented from starting (see 4.4.4.3), would present an electric shock HAZARD, a temperature HAZARD, or a fire HAZARD, shall be protected by an over temperature or thermal protection device meeting the requirements of 14.3.	See above	N/A
14.3/RD	Over temperature protection devices	See above	N/A
14.4/RD	Fuse holders	No such device	N/A
14.5/RD	MAINS voltage selecting devices	See below	P
14.6/RD	Printed circuit boards	V-0 class of PCBs used	P
	Printed circuit boards shall be made of material with a flammability classification of V-1 of IEC 60707 or better	See above	P
	This requirement does not apply to thin-film flexible printed circuit boards that contain only circuits powered from limited power sources meeting the requirements of 9.2.	No such PCBs used	N/A
	Conformity of the flammability RATING is checked by inspection of data on the materials. Alternatively, conformity is checked by performing the V-1 tests specified in IEC 60707 on three samples of the relevant parts.	See cl. no. 14.6	P
14.7/RD	Circuits or components used as transient overvoltage limiting devices	Certified components used.	P
	If control of transient overvoltage is employed in the equipment, any overvoltage limiting component or circuit shall be tested with the applicable impulse withstand voltage of Table 7-10 using the test method from 7.5.1 except 10 positive and 10 negative impulses are to be applied and may be spaced up to 1 min apart.	See above	N/A





URS PRODUCTS AND TESTING PRIVATE LIMITED

A-29, Sector-5, Noida-201301
T +91 (120) 4516264-65 F +91 (120) 4750296
E info@urs-labs.com W www.urs-labs.com
CIN NO U21014UP1987PTC008956



Report No- SC25SPI00626_1

IS 16221 (Part 2) : 2015/ IEC 62109-2 : 2011

Page 60 of 89

Dated : 17/04/2025

Clause	Requirement + Test	Result - Remark	Verdict
14.8/RD	Batteries	No battery used	N/A
	Equipment containing batteries shall be designed to reduce the risk of fire, explosion and chemical leaks under normal conditions and after a single fault in the equipment including a fault in circuitry within the equipment battery pack.	See above cl. no. 14.8	N/A
14.8.1/RD	Battery Enclosure Ventilation	See above cl. no. 14.8	N/A
14.8.1.1/RD	Ventilation requirements	See above cl. no. 14.8	N/A
14.8.1.2/RD	Ventilation testing	See above cl. no. 14.8	N/A
14.8.1.3/RD	Ventilation instructions	See above cl. no. 14.8	N/A
14.8.2/ RD	Battery Mounting	See above cl. no. 14.8	N/A
	Compliance is verified by the application of the force to the battery's mounting surface. The test force is to be increased gradually so as to reach the required value in 5 to 10 s, and is to be maintained at that value for 1 min. A non-metallic rack or tray shall be tested at the highest normal condition operating temperature	See above cl. no. 14.8	N/A
14.8.3/RD	Electrolyte spillage	See above cl. no. 14.8	N/A
	Battery trays and cabinets shall have an electrolyte resistant coating.	See above cl. no. 14.8	N/A
14.8.4/RD	Battery Connections	See above cl. no. 14.8	N/A
	Reverse battery connection of the terminals shall be prevented if reverse connection could result in a hazard within the meaning of this Standard	See above cl. no. 14.8	N/A
14.8.5/RD	Battery maintenance instructions	See above cl. no. 14.8	N/A
	The information and instructions listed in 5.3.4.1 shall be included in the operator manual for equipment in which battery maintenance is performed by the operator, or in the service manual if battery maintenance is to be performed by service personnel only.	See above cl. no. 14.8	N/A
14.8.6/RD	Battery accessibility and maintainability	See above cl. no. 14.8	N/A
	Battery terminals and connectors shall be accessible for maintenance with the correct TOOLS. Batteries with liquid electrolyte, requiring maintained shall be so located that the battery cell caps are accessible for electrolyte tests and readjusting of electrolyte levels.	See above cl. no. 14.8	N/A





URS PRODUCTS AND TESTING PRIVATE LIMITED

A-29, Sector-5, Noida-201301
T +91 (120) 4516264-65 F +91 (120) 4750296
E info@urs-labs.com W www.urs-labs.com
CIN NO U21014UP1987PTC008956



Report No- SC25SPI00626_1

IS 16221 (Part 2) : 2015/ IEC 62109-2 : 2011

Page 61 of 89

Dated : 17/04/2025

Clause	Requirement + Test	Result - Remark	Verdict
--------	--------------------	-----------------	---------

4.2.2.6/4.7 RD	TABLE: mains supply electrical data in normal condition/ Electrical ratings tests					P
Type	U (V) DC	I (A) DC	P (kW) DC	U (V) AC	I (A) AC	P (kW) AC
KSY-6.2KW-1P-22A	254	9.781	2.482	207.38	11.48	2.37
				230.34	10.38	2.38
				253.35	9.58	2.41
	438	14.46	6.336	207.35	29.91	5.579
				230.34	26.52	6.094
				253.33	24.12	6.093

Supplementary information: Nil





URS PRODUCTS AND TESTING PRIVATE LIMITED

A-29, Sector-5, Noida-201301
 T +91 (120) 4516264-65 F +91 (120) 4750296
 E info@urs-labs.com W www.urs-labs.com
 CIN NO U21014UP1987PTC008956



Report No- SC25SPI00626_1

IS 16221 (Part 2) : 2015/ IEC 62109-2 : 2011

Page 62 of 89

Dated : 17/04/2025

Clause	Requirement + Test	Result - Remark				Verdict
4.3/RD	TABLE: Thermal Testing					P
Type/Model:	KSY-6.2KW-1P-22A					--
Temperature t of part/at t 1(°C): 55, t 2(°C): 55					Permitted t (°C)	
Test Condition	DC Input: 254Vdc AC Output: 207.38Vac	DC Input: 254Vdc AC Output: 253.35Vac	DC Input: 438Vdc AC Output: 207.35Vac	DC Input: 438Vdc AC Output: 253.33Vac	--	
Ambient (°C)	55	55	55	55	--	
Metallic Enclosure	63	62	65	64	70	
DC connector	65	67	66	68	85	
AC connector	72	71	73	71	85	
PCB	78	75	76	77	130	
Boost Inductor	82	81	83	85	130	
Power Inductor	85	84	86	88	130	
AC Current sensor (HCT501)	71	72	75	74	85	
GFCI inductor (CT702)	78	79	82	81	130	
Transformer (EC401)	79	77	76	82	110	
Isolated transformer (L601)	82	81	83	80	110	
DC Common-mode Inductor (CT101)	87	88	86	85	110	
AC common-mode inductor (CT501)	88	85	89	88	110	
AC output relay (RY501)	74	75	76	77	85	
X capacitor (C520)	72	73	71	72	85	
Y capacitor (C105)	73	71	72	70	85	

Supplementary information: Temperature test of transformer winding is determined by thermocouple t1 is start temperature t2 is end temperature.





URS PRODUCTS AND TESTING PRIVATE LIMITED

A-29, Sector-5, Noida-201301
 T +91 (120) 4516264-65 F +91 (120) 4750296
 E info@urs-labs.com W www.urs-labs.com
 CIN NO U21014UP1987PTC008956



Report No- SC25SPI00626_1 Page 63 of 89
 Dated : 17/04/2025 IS 16221 (Part 2) : 2015/ IEC 62109-2 : 2011

Clause	Requirement + Test	Result - Remark	Verdict			
4.4.4	TABLE: Single fault condition to be applied		P			
	Ambient temperature (°C).....:	25°C	--			
	Power source for EUT: Manufacturer, model/type, output rating.....:	KSOLARE ENERGY PVT LTD, KSY-6.2KW-1P-22A, 6.2kW	--			
4.4.4.15.1	Fault-tolerance of residual current monitoring					
Component No.	Fault	Supply voltage (V)	Test time	Fuse #	Fuse current (A)	Observation
Input	Reversed	PV input :254Vdc AC output: 230.34Vac	14min	---	---	Unit can't start up. Error message display on the LED + LCD screen No damage, no hazard, no fire
Output	Overload	PV input :438Vdc AC output: 253.33Vac	11min	---	---	Unit works in fault mode, Error message display on the LED + LCD screen. No damage, no hazard, no fire.
Printed circuit board	Short circuited	PV input :438Vdc AC output: 230.33Vac	6min	---	---	Unit shutdown, No damage, no hazard, no fire.
Check that the residual current monitoring operates properly						Yes
Supplementary information: Nil						





URS PRODUCTS AND TESTING PRIVATE LIMITED

A-29, Sector-5, Noida-201301
 T +91 (120) 4516264-65 F +91 (120) 4750296
 E info@urs-labs.com W www.urs-labs.com
 CIN NO U21014UP1987PTC008956



Report No- SC25SPI00626_1

IS 16221 (Part 2) : 2015/ IEC 62109-2 : 2011

Page 64 of 89

Dated : 17/04/2025

Clause	Requirement + Test	Result - Remark	Verdict
4.4.4.17	Cooling system failure – Blanketing test		P
Test voltage (Vdc).....:		438V	---
Test current (Idc)		9.781A	---
Test voltage (Vac).....:		230.34V	---
Test current (Iac)-----:		26.52A	---
t_{amb1} (°C).....:		25	---
t_{amb2} (°C).....:		25	---
maximum temperature T of part/at::		T (°C)	T_{max} (°C)
Enclosure top		72	90
Enclosure side		70	90
Enclosure bottom		75	90
Mounting surface		65	90
Supplementary information: Nil			





URS PRODUCTS AND TESTING PRIVATE LIMITED

A-29, Sector-5, Noida-201301
T +91 (120) 4516264-65 F +91 (120) 4750296
E info@urs-labs.com W www.urs-labs.com
CIN NO U21014UP1987PTC008956



TC-6468

Report No- SC25SPI00626_1

IS 16221 (Part 2) : 2015/ IEC 62109-2 : 2011

Page 65 of 89

Dated : 17/04/2025

Clause	Requirement + Test	Result - Remark	Verdict
4.7.4	TABLE: Steady state Inverter AC output voltage and frequency		N/A
	Nominal DC input (V) Nominal output AC voltage (V) :	----	
AC output U (V)	Frequency (Hz)	Condition/status	Comments
----	----	Without load	----
----	----	Resistive load application	----
----	----	Resistive load removal	----
Supplementary information: The PCE is not a standalone unit; therefore, the Steady State Inverter AC output voltage and frequency is not deemed applicable.			





URS PRODUCTS AND TESTING PRIVATE LIMITED

A-29, Sector-5, Noida-201301
 T +91 (120) 4516264-65 F +91 (120) 4750296
 E info@urs-labs.com W www.urs-labs.com
 CIN NO U21014UP1987PTC008956



Report No- SC25SPI00626_1 IS 16221 (Part 2) : 2015/ IEC 62109-2 : 2011 Page 66 of 89
 Dated : 17/04/2025

Clause	Requirement + Test	Result - Remark			Verdict
4.8.2	TABLE: Array insulation resistance detection for inverters for ungrounded and functionally grounded arrays			P	
4.8.2.1	Array insulation resistance detection for inverters for ungrounded arrays			P	
DC Voltage below minimum operating voltage (V)	DC Voltage for inverter begin operation (V)	Resistance between ground and PV input terminal (kΩ)	Required Insulation resistance R = (VMAX PV/ 30mA) (kΩ)	Result	
DC+					
65	254	16.50	18.33	Unit can't start up, Error message on display Isolation fault	
65	363	16.50	18.33	Unit can't start up, Error message on display Isolation fault	
65	438	16.50	18.33	Unit can't start up, Error message on display Isolation fault	
DC-					
65	254	16.50	18.33	Unit can't start up, Error message on display Isolation fault	
65	363	16.50	18.33	Unit can't start up, Error message on display Isolation fault	
65	438	16.50	18.33	Unit can't start up, Error message on display Isolation fault	
<p>Note: For isolated inverters, shall indicate a fault in accordance with 13.9 (operation is allowed); the fault indication shall be maintained until the array insulation resistance has recovered to a value higher than the limit above For non-isolated inverters, or inverters with isolation not complying with the leakage current limits in the minimum inverter isolation requirements in Table 30, shall indicate a fault in accordance with 13.9, and shall not connect to the mains; the inverter may continue to make the measurement, may stop indicating a fault and may connect to the mains if the array insulation resistance has recovered to a value higher than the limit above. It is not required to test all PV input terminals if analysis of the design indicates that one or more terminals can be expected to have the same result, for example where multiple PV string inputs are in parallel.</p>					
Supplementary information: Nil					





URS PRODUCTS AND TESTING PRIVATE LIMITED

A-29, Sector-5, Noida-201301
 T +91 (120) 4516264-65 F +91 (120) 4750296
 E info@urs-labs.com W www.urs-labs.com
 CIN NO U21014UP1987PTC008956



Report No- SC25SPI00626_1

IS 16221 (Part 2) : 2015/ IEC 62109-2 : 2011

Page 67 of 89

Dated : 17/04/2025

Clause	Requirement + Test	Result - Remark	Verdict
4.8.3.2	TABLE: 30mA touch current type test for isolated inverters		N/A
	Condition	Current (mA)	Limit (30mA)
	DC+ to PE	---	---
	DC- to PE	---	---
Supplementary information:			
<ul style="list-style-type: none"> • The touch current measurement circuit of IEC60990, Figure 4 is connected from each terminal of the array to ground, one at a time. • The EUT is non-isolated inverter 			

Clause	Requirement + Test	Result - Remark	Verdict
4.8.3.3	TABLE: Fire hazard residual current type test for isolated inverters		N/A
	Condition	Current (mA)	Limit (300mA or 10mA per kVA)
	DC+ to PE	---	---
	DC- to PE	---	---
Supplementary information: The EUT is non-isolated inverter			





URS PRODUCTS AND TESTING PRIVATE LIMITED

A-29, Sector-5, Noida-201301
 T +91 (120) 4516264-65 F +91 (120) 4750296
 E info@urs-labs.com W www.urs-labs.com
 CIN NO U21014UP1987PTC008956



Report No- SC25SPI00626_1 IS 16221 (Part 2) : 2015/ IEC 62109-2 : 2011 Page 68 of 89
 Dated : 17/04/2025

Clause	Requirement + Test	Result - Remark	Verdict
--------	--------------------	-----------------	---------

4.8.3.5	TABLE: Protection by residual current monitoring		P
---------	---	--	----------

Test conditions:	Output power (W): 62000 Input voltage (VDC): 438 Frequency (Hz): 50 Output AC Voltage (VAC): 230.34
-------------------------	---

4.8.3.5.2	Test for detection of excessive continuous residual current		P
-----------	--	--	----------

Fault Current (mA)		Disconnection time (ms)	
Measured Fault Current	Limit	Measured Disconnection time	Limit
+ PV to N:			
84	300	72	300
76	300	61	300
126	300	45	300
152	300	42	300
158	300	74	300
- PV to N:			
72	300	56	300
86	300	72	300
98	300	47	300
141	300	56	300
156	300	37	300

Note:

- maximum 300mA for inverters with continuous output power rating $\leq 30\text{kVA}$;
- maximum 10mA per kVA of rated continuous output power for inverters with continuous output power rating $> 30\text{kVA}$.

This test shall be repeated 5 times, and for all 5 tests the time to disconnect shall not exceed 0.3s.
 The test is repeated for each PV input terminal. It is not required to test all PV input terminals if analysis of the design indicates that one or more terminals can be expected to have the same result, for example where multiple PV string inputs are in parallel.

Supplementary information: Nil





URS PRODUCTS AND TESTING PRIVATE LIMITED

A-29, Sector-5, Noida-201301
 T +91 (120) 4516264-65 F +91 (120) 4750296
 E info@urs-labs.com W www.urs-labs.com
 CIN NO U21014UP1987PTC008956



Report No- SC25SPI00626_1

IS 16221 (Part 2) : 2015/ IEC 62109-2 : 2011

Page 69 of 89

Dated : 17/04/2025

Clause	Requirement + Test	Result - Remark	Verdict
4.8.3.5.3	TABLE: Test for detection of sudden changes in residual current		P
	+PV to N		
Limit (mA)	U_N		Limit(ms)
	Disconnection time (ms)		
30	125		300
30	121		300
30	189		300
30	142		300
30	119		300
60	75		150
60	94		150
60	78		150
60	72		150
60	74		150
150	28		40
150	29		40
150	24		40
150	12		40
150	19		40
	-PV to N		
Limit (mA)	U_N		Limit(ms)
	Disconnection time (ms)		
30	185		300
30	152		300
30	174		300
30	141		300
30	126		300
60	74		150
60	76		150
60	68		150
60	69		150
60	64		150
150	24		40
150	29		40
150	14		40
150	26		40

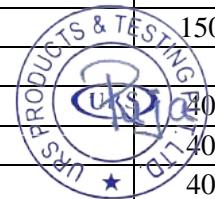



URS PRODUCTS AND TESTING PRIVATE LIMITED

A-29, Sector-5, Noida-201301
T +91 (120) 4516264-65 F +91 (120) 4750296
E info@urs-labs.com W www.urs-labs.com
CIN NO U21014UP1987PTC008956



Report No- SC25SPI00626_1

IS 16221 (Part 2) : 2015/ IEC 62109-2 : 2011

Page 70 of 89

Dated : 17/04/2025

Clause	Requirement + Test	Result - Remark	Verdict
150		18	40
Note: The capacitive current is risen until disconnection.			
Test condition: $I_c + 30/60/150\text{mA} \leq I_{c\text{max}}$. R_1 is set that 30/60/150mA Flow and switch S is closed.			
Supplementary information:			





URS PRODUCTS AND TESTING PRIVATE LIMITED

A-29, Sector-5, Noida-201301
T +91 (120) 4516264-65 F +91 (120) 4750296
E info@urs-labs.com W www.urs-labs.com
CIN NO U21014UP1987PTC008956



Report No- SC25SPI00626_1

IS 16221 (Part 2) : 2015/ IEC 62109-2 : 2011

Page 71 of 89

Dated : 17/04/2025

Clause	Requirement + Test	Result - Remark	Verdict
--------	--------------------	-----------------	---------

7.3.6.3.3/RD	TABLE: Protective equipotential bonding		N/A
--------------	---	--	-----

Measured between	Test Current (A)	Voltage drop (V)	Resistance (mOhm)	Result
--	--	--	--	--

Supplementary information: Protective equipotential bonding requirements complies with cl. No.7.6.3.3.5. Instruction regarding connection of earthing conductor provided in user manual.

7.3.6.3.7/RD	TABLE: Touch current measurement			P
--------------	----------------------------------	--	--	---

Measured between	Measured (mA)	Limit (mA)	Comments/Conditions
External protective earthing conductor and earthing terminal of PCE	1.21	3.5	---

Supplementary information: Nil





URS PRODUCTS AND TESTING PRIVATE LIMITED

A-29, Sector-5, Noida-201301
 T +91 (120) 4516264-65 F +91 (120) 4750296
 E info@urs-labs.com W www.urs-labs.com
 CIN NO U21014UP1987PTC008956



Report No- SC25SPI00626_1

IS 16221 (Part 2) : 2015/ IEC 62109-2 : 2011

Page 72 of 89

Dated : 17/04/2025

Clause	Requirement + Test	Result - Remark					Verdict
7.3.7/RD	TABLE: Clearance and creepage measurements					P	
Measured between	Up (V)	U r.m.s (V)	Required cl (mm)	cl (mm)	Required cr (mm)	Cr (mm)	
PV1- to PV1+ (FI)	550	---	3.0	8.83	3.0	8.83	
Line to ground (BI)	326	230	3.0	10.89	3.0	10.89	
Line to neutral (FI)	326	230	3.0	5.02	3.0	5.02	
PV circuit to ground across (BI)	550	--	3.0	11.88	3.0	11.88	
Primary pin to secondary pin of Transformer (EC401)(RI)	326	230	5.5	14.18	5.5	14.18	
Supplementary information: FI: Functional insulation, BI: Basic insulation, RI: Reinforced insulation							

7.3.7/RD	TABLE: Distance through insulation measurement				P
Distance through insulation	U r.m.s (V)	Test volatge (V)	Required di (mm)	Di (mm)	
Transformer (EC401) Insulating Sheet	230	3000	>0.2	>0.2	
Supplementary information: Nil					





URS PRODUCTS AND TESTING PRIVATE LIMITED

A-29, Sector-5, Noida-201301
T +91 (120) 4516264-65 F +91 (120) 4750296
E info@urs-labs.com W www.urs-labs.com
CIN NO U21014UP1987PTC008956



Report No- SC25SPI00626_1

IS 16221 (Part 2) : 2015/ IEC 62109-2 : 2011

Page 73 of 89

Dated : 17/04/2025

Clause	Requirement + Test	Result - Remark			Verdict
7.5/RD	TABLE: electric strength measurements, impulse voltage test and partial discharge test			P	
	Test voltage applied between	Test volatge (V)	Impulse withstand voltage (V)	Partial discharge voltage (V)	Results
	PV terminal to ground (BI)	1500	4000	---	Pass
	AC terminal to ground (BI)	1500	4000	---	Pass
	LN shorted together and accessible panel (RI)	3000	6000	---	Pass
	PV circuit to SELV circuit (RI)	3000	6000	---	Pass
Supplementary information: BI: Basic insulation, RI: Reinforced insulation					





URS PRODUCTS AND TESTING PRIVATE LIMITED

A-29, Sector-5, Noida-201301
T +91 (120) 4516264-65 F +91 (120) 4750296
E info@urs-labs.com W www.urs-labs.com
CIN NO U21014UP1987PTC008956



Report No- SC25SPI00626_1

IS 16221 (Part 2) : 2015/ IEC 62109-2 : 2011

Page 74 of 89

Dated : 17/04/2025

Clause	Requirement + Test	Result - Remark	Verdict	
9.2/RD	TABLE: Limited power sources		N/A	
Circuit output tested				
Components	Uoc (V)	Isc (A)		VA
		Meas.	Limit	
---	---	---	---	---
Supplementary information: No such circuit				





URS PRODUCTS AND TESTING PRIVATE LIMITED

A-29, Sector-5, Noida-201301
 T +91 (120) 4516264-65 F +91 (120) 4750296
 E info@urs-labs.com W www.urs-labs.com
 CIN NO U21014UP1987PTC008956



Report No- SC25SPI00626_1

IS 16221 (Part 2) : 2015/ IEC 62109-2 : 2011

Page 75 of 89

Dated : 17/04/2025

Clause	Requirement + Test		Result - Remark		Verdict
14	TABLE: List of critical components				P
Object/Part No	Manufacturer/Trademark	Type/Model	Technical Data	Standard	Marks of Conformity1
Mettallic Enclosure	Suzhu Gangwang Metal Technology Co., Ltd	Aluminium alloy	thickness: 2,6mm	IS 16221 (Part 2) : 2015/ IEC 62109-2 : 2011	Tested with equipment
Plastic window	Suzhou Omay Optical Materials Co., Ltd.	UV11	Size 1 using on the model without LCD: 118,5*34,5*0,5; Size 1 using on the model without LCD: 167,3*62,1*0,5; flammability: V-2	UL 94 (Harmonized with IEC 60695-11-10)	UL E249605
Alternate	Coverstro Deutschland AG	DE 6-2	Size 1 using on the model without LCD: 118,5*34,5*0,5; Size 1 using on the model without LCD: 167,3*62,1*0,5; flammability: V-2	UL 94 (Harmonized with IEC 60695-11-10)	UL E168120
DC connector	Phoenix Contact GmbH & Co.KG	PV-CF-S 2,5-6(+)	1100V/40A	IEC/EN 62852:2014	TUV R60126961
Alternate	Phoenix Contact GmbH & Co.KG	PV-CM-S 2,5-6(-)	1100V/40A	IEC/EN 62852:2014	TUV R60126961
Alternate	Amphenol Technology (Shenzhen)Co., Ltd.	H4CMB4TM	1000V/39A	IEC/EN 62852:2014	TUV R50388083
Alternate	Amphenol Technology (Shenzhen)Co., Ltd.	H4CFB4TM	1000V/39A	IEC/EN 62852:2014	TUV R50388083
DC conneceting wires	3Q wire&cable Co.,Ltd.	12071	12AWG, 1000V	UL 758 (Harmonized IEC standard not available)	UL E341104
Alternate	3Q wire&cable Co.,Ltd.	10269	12AWG, 1000V	UL 758 (Harmonized IEC standard not available)	UL E341104
AC Current sensor (HCT501)	LEM	LESR 25NP or CASR 25NP	-85A...85A, Secondary supply	UL 508 (Harmonized IEC	UL E189713

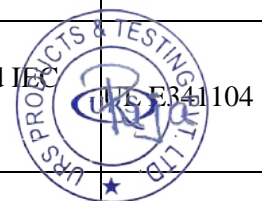



URS PRODUCTS AND TESTING PRIVATE LIMITED

A-29, Sector-5, Noida-201301
 T +91 (120) 4516264-65 F +91 (120) 4750296
 E info@urs-labs.com W www.urs-labs.com
 CIN NO U21014UP1987PTC008956



Report No- SC25SPI00626_1

IS 16221 (Part 2) : 2015/ IEC 62109-2 : 2011

Page 76 of 89

Dated : 17/04/2025

Clause	Requirement + Test		Result - Remark	Verdict
			voltage: 5Vdc	standard not available)
Alternate	Tamura Corp	F02P025S05L	-85A...85A, Secondary supply voltage: 5Vdc	UL 508 (Harmonized IEC standard not available) UL E243511
AC output relay (RY501~RY504)	Xiamen Hongfa	HF161F-W/12-HF	12Vdc,250Vac, 31A , contact gap>1.8mm	IEC/EN 61810-1:2015 VDE 40031410
Alternate	FCL COMPONENTS LIMITED	FTR-K3AB012W-PS	12Vdc,250Vac, 32A , contact gap>1.8mm	IEC/EN 61810-1:2015 VDE 40011330
X capacitor (C508,C509)	Xiamen Faratronic Co.,Ltd	C45S1334M91C350	X1, 440Vac, 0.33µF	IEC/UL 60384-14 UL E186600
X capacitor (C106,C122)	Xiamen Faratronic Co.,Ltd	C3D3L105	1.0 µF; rated operation voltage:1200Vdc	UL810 (Harmonized IEC standard not available) UL E256238
X capacitor (C107,C123)	Xiamen Faratronic Co.,Ltd	C3D2K146	capacitance : 14uf; rated operation voltage:800Vdc	IEC/EN 61071:2007 IEC/EN 61881-1:2010 TUV R 50266108
X capacitor (C510)	Xiamen Faratronic Co.,Ltd	C4BQ2475KFWC450	X2, 305Vac, 4.7 µF	IEC/UL 60384-14 UL E186600
X capacitor (C520)	Xiamen Faratronic Co.,Ltd	C4BQ2335MBWC450	X2, 305Vac, 3.3 µF	IEC/UL 60384-14:2014 UL E186600
Y capacitor (C103,C115,C119)	Xiamen Faratronic Co.,Ltd	C47S1102	Y1, capacitance: 0.001 µF; rated operation voltage:400Vac, 50/60Hz	IEC/UL 60384-14 UL E186600
Y capacitor (C105,C117,C121)	Xiamen Faratronic Co.,Ltd	C47H2472	Y1,capacitance: 0.0047 µF; rated operation voltage:500Vac, 50/60Hz	IEC/UL 60384-14 UL E186600
Y capacitor (C513, C514)	Xiamen Faratronic Co.,Ltd	C43Q1473M6SC450	Y2, 300Vac, 0.047 µF	IEC/UL 60384-14 UL E186600
Y capacitor (C521, C522)	Xiamen Faratronic Co.,Ltd	C47S1222M60C350	Y1, 440Vac, 2.2nF,	IEC/UL 60384-14 UL E186600
Y capacitor (C523,C524)	Vishay	BFC233860223	Y2, 300Vac,0.022nF	IEC/UL 60384-14 UL E354331

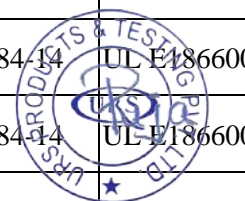



URS PRODUCTS AND TESTING PRIVATE LIMITED

A-29, Sector-5, Noida-201301
 T +91 (120) 4516264-65 F +91 (120) 4750296
 E info@urs-labs.com W www.urs-labs.com
 CIN NO U21014UP1987PTC008956



Report No- SC25SPI00626_1

IS 16221 (Part 2) : 2015/ IEC 62109-2 : 2011

Page 77 of 89

Dated : 17/04/2025

Clause	Requirement + Test	Result - Remark	Verdict
DC Common-mode Inductor (CT101)	wuxi jinglei electronic co.,ltd	H561-11000-00 Class B	IS 16221 (Part 2) : 2015/ IEC 62109-2 : 2011 Tested with Equipment
Bobbin	SUMITOMO BAKELITE Co.,Ltd	PM-9823 150°C	UL 94 (Harmonized with IEC 60695-11-10) UL E41429
Tubing	KINGBOARD LAMINATES HOLDINGS LTD	KB-150 155°C	UL 224 (Harmonized IEC Standard not available) UL E123995
Varnishe	SUZHOU TAIHU ELECTRIC ADVANCED MATERIAL CO LTD	T-4260(a) 200°C	UL 1446 (Harmonized IEC standard not available) UL E228349
Boost Inductor	Huizhou Inductance Electronic Technology Co., Ltd.	H561-10002-00 Class F	IS 16221 (Part 2) : 2015/ IEC 62109-2 : 2011 Tested with Equipment
Magnet wire	Jung Shing wire Co., ltd	EISVW, ESVR(b) 180°C	UL 1446 (Harmonized IEC Standard not available) UL E174837
Alternate	TAI-I ELECTRIC WIRE & CABLE CO LTD	EIW 180°C	UL 1446 (Harmonized IEC Standard not available) UL E85640
Alternate	PACIFIC ELECTRIC WIRE & CABLE (SHENZHEN) CO LTD	PEWH/U 180°C	UL 1446 (Harmonized IEC Standard not available) UL E201757
Alternate	Guangdong Jinyan Electrotechnics Joint Stock Co Ltd	xEIW 180°C	UL 1446 (Harmonized IEC Standard not available) UL E238500
Alternate	DONGGUAN YIDA INDUSTRIAL CO LTD	*EIW 180°C	UL 1446 (Harmonized IEC Standard not available) UL E344055
Alternate	Tongling Jingda Special Magnet Wire Co Ltd	QZY-2/180 180°C	UL 1446 (Harmonized IEC Standard not available) UL E223994

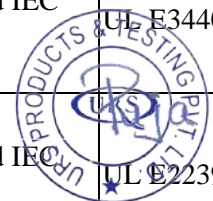



URS PRODUCTS AND TESTING PRIVATE LIMITED

A-29, Sector-5, Noida-201301
 T +91 (120) 4516264-65 F +91 (120) 4750296
 E info@urs-labs.com W www.urs-labs.com
 CIN NO U21014UP1987PTC008956



Report No- SC25SPI00626_1

IS 16221 (Part 2) : 2015/ IEC 62109-2 : 2011

Page 78 of 89

Dated : 17/04/2025

Clause	Requirement + Test		Result - Remark		Verdict
Insulating Tape	JINGJIANG YAHUA PRESSUER SENSITIVE GLUE CO LTD	CT* (b)(g)	130°C	UL 510 (Harmonized IEC Standard not available)	UL E165111
Alternate	CHANG SHU LIANG YI TAPE INDUSTRY CO LTD	LY-XX*	130°C	UL 510 (Harmonized IEC Standard not available)	UL E246820
Margin Tape	JINGJIANG YAHUA PRESSUER SENSITIVE GLUE CO LTD	WFF(f)	130°C	UL 510 (Harmonized IEC Standard not available)	UL E165111
Alternate	CHANG SHU LIANG YI TAPE INDUSTRY CO LTD	LY19-02-*	130°C	UL 510 (Harmonized IEC Standard not available)	UL E246820
Varnish	ZHUHAI CHANGX IANNEW MATERLALS TECHNOLOGY CO LTD	E962	130°C	UL 1446 (Harmonized IEC Standard not available)	UL E335405
Lead wire	3Q WIRE&CABLE CO LTD	1015	600V, 105°C	UL 758 (Harmonized IEC Standard not available)	UL E341104
Alternate	GUANGDONG HAERKN NEW ENERGY CO LTD	1015	600V, 105°C	UL 758 (Harmonized IEC Standard not available)	UL E300956
Alternate	LTK ELECTRIC WIRE (HUIZHOU) LTD	1015	600V, 105°C	UL 758 (Harmonized IEC Standard not available)	UL E148000
Alternate	DONGGUAN WENCHANG ELECTRONIC CO LTD	1015	600V, 105°C	UL 758 (Harmonized IEC Standard not available)	UL E214500
Tube	SHENZHEN WOER HEAT-SHRINKABLE	RSFR-H	125°C	UL 224 (Harmonized IEC	UL E203950

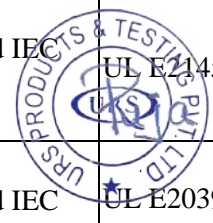



URS PRODUCTS AND TESTING PRIVATE LIMITED

A-29, Sector-5, Noida-201301
 T +91 (120) 4516264-65 F +91 (120) 4750296
 E info@urs-labs.com W www.urs-labs.com
 CIN NO U21014UP1987PTC008956



Report No- SC25SPI00626_1

IS 16221 (Part 2) : 2015/ IEC 62109-2 : 2011

Page 79 of 89

Dated : 17/04/2025

Clause	Requirement + Test		Result - Remark		Verdict
	MATERIAL CO LTD			Standard not available)	
Power Inductor	Qingdao Yunlu Energy Technology Co., Ltd	00-43-001	Class C	IS 16221 (Part 2) : 2015/ IEC 62109-2 : 2011	Tested with Equipment
Magnet Wire	Tongling jingda	Q(ZY/XY)-2/200	200°C	UL 1446 (Harmonized IEC Standard not available)	UL E174580
Alternate	liaoning donggang	Q(ZY/XY)-2/220(L)	200°C	UL 1446 (Harmonized IEC Standard not available)	UL E229247
lead wire	LTK ELECTRIC WIRE	10269	1000V, 12AWG	UL 758 (Harmonized IEC Standard not available)	UL E148000
Alternate	JIAXING TITION WIRE CO LTD	10269	1000V, 12AWG	UL 758 (Harmonized IEC Standard not available)	UL E320271
Alternate	3Q WIRE	10269	1000V, 12AWG	UL 758 (Harmonized IEC Standard not available)	UL E341104
Tube	SHENZHEN WOER HEAT-SHRINKABLE MATERIAL CO LTD	RSFR-H	125°C	UL 224 (Harmonized IEC Standard not available)	UL E203950
Alternate	JINGJIANG JINGYI ADHESIVE PRODUCT CO LTD	JY25-A (b)	130°C	UL 224 (Harmonized IEC Standard not available)	UL E246950
Tape	Qingyuan Better New Materials Co Ltd	Better 116(n)	155°C	UL 510 (Harmonized IEC Standard not available)	UL E316816
Varnishes	SUZHOU TAIHU ELECTRIC ADVANCED MATERIAL CO LTD	T-4260(a)	180°C	UL 1446 (Harmonized IEC Standard not available)	UL E228349

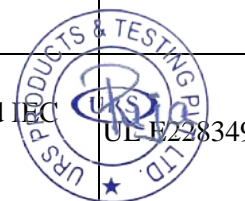



URS PRODUCTS AND TESTING PRIVATE LIMITED

A-29, Sector-5, Noida-201301
 T +91 (120) 4516264-65 F +91 (120) 4750296
 E info@urs-labs.com W www.urs-labs.com
 CIN NO U21014UP1987PTC008956



Report No- SC25SPI00626_1

IS 16221 (Part 2) : 2015/ IEC 62109-2 : 2011

Page 80 of 89

Dated : 17/04/2025

Clause	Requirement + Test		Result - Remark	Verdict
AC common-mode inductor (CT501)	Wuxi jinglei electronic co.,ltd	561-11001-00	Class B	IS 16221 (Part 2) : 2015/ IEC 62109-2 : 2011 Tested with Equipment
Bobbin	SUMITOMO BAKELITE Co.,Ltd	PM-9823	150°C	UL 94 (Harmonized with IEC 60695-11-10) UL E41429
Tubing	KINGBOARD LAMINATES HOLDINGS LTD	KB-150	155°C	UL 224 (Harmonized IEC Standard not available) UL E123995
Varnishe	SUZHOU TAIHU ELECTRIC ADVANCED MATERIAL CO LTD	T-4260(a)	200°C	UL 1446 (Harmonized IEC standard not available) UL E228349
GFCI inductor (CT702)	Wuxi Jinglei Electronic Co., ltd	560-20003-00	Class F	IS 16221 (Part 2) : 2015/ IEC 62109-2 : 2011 Tested with equipment
Bobbin	SUMITOMO BAKELITE Co.,Ltd	PM-9823	150°C	UL 94 (Harmonized with IEC 60695-11-10) UL E41429
Tubing	SHENZHEN WOER HEAT-SHRINKABLE MATERIAL CO LTD	RSFR-H	200°C	UL 224 (Harmonized IEC Standard not available) UL E203950
Magnet Wire	jiangsu dartong M&E Co.,ltd	MW75-C	130°C	UL 1446 (Harmonized IEC Standard not available) UL E237377
Transformer (EC401)	wuxi jinglei electronic co.,ltd	H560-00000-00	Class B	IS 16221 (Part 2) : 2015/ IEC 62109-2 : 2011 Tested with equipment
Bobbin	SUMITOMO BAKELITE Co.,Ltd	PM-9823	150°C	UL 94 (Harmonized IEC Standard not available) UL E41429
Magnet Wire	jiangsu dartong M&E Co.,ltd	MW75-C	130°C	UL 1446 (Harmonized IEC Standard not available) UL E237377
Alternate	COSMOLINK CO.,LTD	TIW-M	130°C	UL 1446 (Harmonized IEC Standard not available) UL E213764

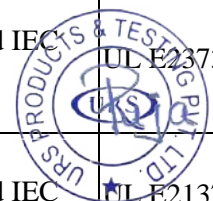



URS PRODUCTS AND TESTING PRIVATE LIMITED

A-29, Sector-5, Noida-201301
 T +91 (120) 4516264-65 F +91 (120) 4750296
 E info@urs-labs.com W www.urs-labs.com
 CIN NO U21014UP1987PTC008956



Report No- SC25SPI00626_1

IS 16221 (Part 2) : 2015/ IEC 62109-2 : 2011

Page 81 of 89

Dated : 17/04/2025

Clause	Requirement + Test		Result - Remark	Verdict
			available)	
INSULATION TAPE	JINGJIANG YAHUA PRESSURE SENSITIVE GLUE CO LTD	CT* (c)(g)	130 °C	UL 510 (Harmonized IEC Standard not available) UL E165111
Alternate	JINGJIANG YAHUA ELECTRONIC SCIENCE&TECHNOLOGY CO LTD	WF-2901	130°C	UL 510 (Harmonized IEC Standard not available) UL E165111
TUBE	Great holding industrial co.,ltd	TFT	200°C	UL 224 (Harmonized IEC Standard not available) UL E156256
Epoxy	DONGGUAN EATTO ELECTRONIC MATERIAL CO LTD	3300A-1/3300B-1	V-0, 130°C	UL 94 (Harmonized with IEC 60695-11-10) UL E218090
Varnish	wujiang taihu insulating materials co.,ltd	T-4260(a)	155°C	UL 1446 (Harmonized IEC Standard not available) UL E228349
Isolated transformer (L601)	Huizhou Inductance Electronics Technology Co.,Ltd	H560-00003-00	Class B	IS 16221 (Part 2) : 2015/ IEC 62109-2 : 2011 Tested with Equipment
Bobbin	CHANG CHUN PLASTICS CO.,LTD	T375J(G5)(G6)	150°C	UL 94 (Harmonized with IEC 60695-11-10) UL E59481
Magnet wire	HUIZHOU HUILI INDUSTRIAL CO LTD	MIW-B(x)	130°C	UL 1446 (Harmonized IEC Standard not available) UL E322908
TIW	SUZHOU YUSHENG ELECTRONIC CO LTD	FLW-B-SB*	130°C	UL 2353 (No Harmonized IEC standard available) UL E332529
Insulating Tape	JINGJIANG YAHUA PRESSUER SENSITIVE GLUE CO LTD	CT* (b)(g)	0,05mm, 130°C	UL 510 (Harmonized IEC Standard not available) UL E165111
Alternate	CHANG SHU LIANG YI TAPE INDUSTRY CO LTD	LY-XX*	130°C	UL 510 (Harmonized IEC Standard not available) UL E246820

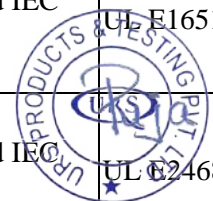



URS PRODUCTS AND TESTING PRIVATE LIMITED

A-29, Sector-5, Noida-201301
 T +91 (120) 4516264-65 F +91 (120) 4750296
 E info@urs-labs.com W www.urs-labs.com
 CIN NO U21014UP1987PTC008956



Report No- SC25SPI00626_1

IS 16221 (Part 2) : 2015/ IEC 62109-2 : 2011

Page 82 of 89

Dated : 17/04/2025

Clause	Requirement + Test		Result - Remark	Verdict
Varnish	ZHUHAI CHANGXIAN NEW MATERLALS TECHNOLOGY CO LTD	E962	130°C	UL 1446 (Harmonized IEC Standard not available) UL E335405
Optocoupler (U807,U808, U1202,U1203)	VISHAY INFRARED COMPONENTS INC	SFH615A*	clearance≥7mm, Maximum rated withstanding isolation voltage: 4470Vrms	UL1577 (Harmonized IEC Standard not available) UL E52744
Digital isolator (U1105)	Suzhou Novosense Microelectronics Co.,Ltd	NSi8130W1	clearance≥7.8mm, Maximum rated withstanding isolation voltage: 5000Vrms	UL1577 (Harmonized IEC Standard not available) UL E500602
AC Connector	Dongguan Vaconn Electronic Technology Co., Ltd.	VPAC07EW-3S	300Vac, 30A	IEC/EN 61984:2009 TUV Rh. R50235418
Alternate	Suzhou Exceedconn technology Co.,Ltd	EN030-1026-0001	250Vac, 25A,	IEC/EN 61535:2009/A1:2013 TUV B151177046018
Alternate	Suzhou Exceedconn technology Co.,Ltd	EN030-1128-1001	250Vac, 32A	IEC/EN 61535:2009/A1:2013 TUV B180477046050
AC output wires	3Q wire&cable Co.,Ltd.	12071	1000V, 12AWG	UL 758 (Harmonized IEC Standard not available) UL E341104
Alternate	3Q wire&cable Co.,Ltd.	10269	1000V, 12AWG	UL 758 (Harmonized IEC Standard not available) UL E341104
PCB	TONGLING ONBOLE PCB CO LTD	D1	V-0, 130°C	UL 796 (Harmonized IEC Standard not available) UL E488128
Alternate	NAN YA PLASTICS CORP CCL DEPT ELECTRONIC MATERIAL DIV	NP-155FR	V-0, 130°C	UL 796 (Harmonized IEC Standard not available) UL E98983
ISO relay (K701)	Xiamen Hongfa Electroacoustic Co., Ltd.	HFD3-V/12-SR	maixmum cut off voltage:1000Vdc, clearance ≥1.5mm	IEC 61810-1:2015 VDE 140018867
Insulation sheet under IGBT/NTC thermistor	Bergquist	K-10#	VTM-0, 6000Vac	UL 94 (Harmonized with IEC 60695-11-10) UL E59150

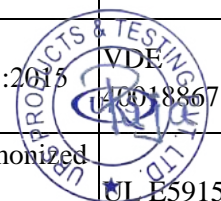



URS PRODUCTS AND TESTING PRIVATE LIMITED

A-29, Sector-5, Noida-201301
T +91 (120) 4516264-65 F +91 (120) 4750296
E info@urs-labs.com W www.urs-labs.com
CIN NO U21014UP1987PTC008956



Report No- SC25SPI00626_1

IS 16221 (Part 2) : 2015/ IEC 62109-2 : 2011

Page 83 of 89

Dated : 17/04/2025

Clause	Requirement + Test	Result - Remark			Verdict
Alternate	Mylar Hongji Films Foshan Co Ltd	EM	VTM-2, 6000Vac	UL 94 (Harmonized with IEC 60695-11-10)	UL E241830

Supplementary Information: ¹Evidence provided by the manufacturer for the listed components are verified by us and the evidence are conforming to the requirement of relevant standard.





URS PRODUCTS AND TESTING PRIVATE LIMITED

A-29, Sector-5, Noida-201301
T +91 (120) 4516264-65 F +91 (120) 4750296
E info@urs-labs.com W www.urs-labs.com
CIN NO U21014UP1987PTC008956



Report No- SC25SPI00626_1

IS 16221 (Part 2) : 2015/ IEC 62109-2 : 2011

Page 84 of 89

Dated : 17/04/2025

Clause	Requirement + Test	Result - Remark	Verdict
--------	--------------------	-----------------	---------

Attachment-1



Front View





URS PRODUCTS AND TESTING PRIVATE LIMITED

A-29, Sector-5, Noida-201301
T +91 (120) 4516264-65 F +91 (120) 4750296
E info@urs-labs.com W www.urs-labs.com
CIN NO U21014UP1987PTC008956



Report No- SC25SPI00626_1

IS 16221 (Part 2) : 2015/ IEC 62109-2 : 2011

Page 85 of 89

Dated : 17/04/2025

Clause	Requirement + Test	Result - Remark	Verdict
--------	--------------------	-----------------	---------



Rear View





URS PRODUCTS AND TESTING PRIVATE LIMITED

A-29, Sector-5, Noida-201301
T +91 (120) 4516264-65 F +91 (120) 4750296
E info@urs-labs.com W www.urs-labs.com
CIN NO U21014UP1987PTC008956



Report No- SC25SPI00626_1

IS 16221 (Part 2) : 2015/ IEC 62109-2 : 2011

Page 86 of 89

Dated : 17/04/2025

Clause	Requirement + Test	Result - Remark	Verdict
--------	--------------------	-----------------	---------



Port View





URS PRODUCTS AND TESTING PRIVATE LIMITED

A-29, Sector-5, Noida-201301
T +91 (120) 4516264-65 F +91 (120) 4750296
E info@urs-labs.com W www.urs-labs.com
CIN NO U21014UP1987PTC008956



Report No- SC25SPI00626_1

IS 16221 (Part 2) : 2015/ IEC 62109-2 : 2011

Page 87 of 89

Dated : 17/04/2025

Clause	Requirement + Test	Result - Remark	Verdict
--------	--------------------	-----------------	---------



Internal View





URS PRODUCTS AND TESTING PRIVATE LIMITED

A-29, Sector-5, Noida-201301
T +91 (120) 4516264-65 F +91 (120) 4750296
E info@urs-labs.com W www.urs-labs.com
CIN NO U21014UP1987PTC008956



TC-6468

Report No- SC25SPI00626_1

IS 16221 (Part 2) : 2015/ IEC 62109-2 : 2011

Page 88 of 89

Dated : 17/04/2025

Clause	Requirement + Test	Result - Remark	Verdict
--------	--------------------	-----------------	---------



PCB Front View





URS PRODUCTS AND TESTING PRIVATE LIMITED

A-29, Sector-5, Noida-201301
T +91 (120) 4516264-65 F +91 (120) 4750296
E info@urs-labs.com W www.urs-labs.com
CIN NO U21014UP1987PTC008956



Report No- SC25SPI00626_1

IS 16221 (Part 2) : 2015/ IEC 62109-2 : 2011

Page 89 of 89

Dated : 17/04/2025

Clause	Requirement + Test	Result - Remark	Verdict
--------	--------------------	-----------------	---------

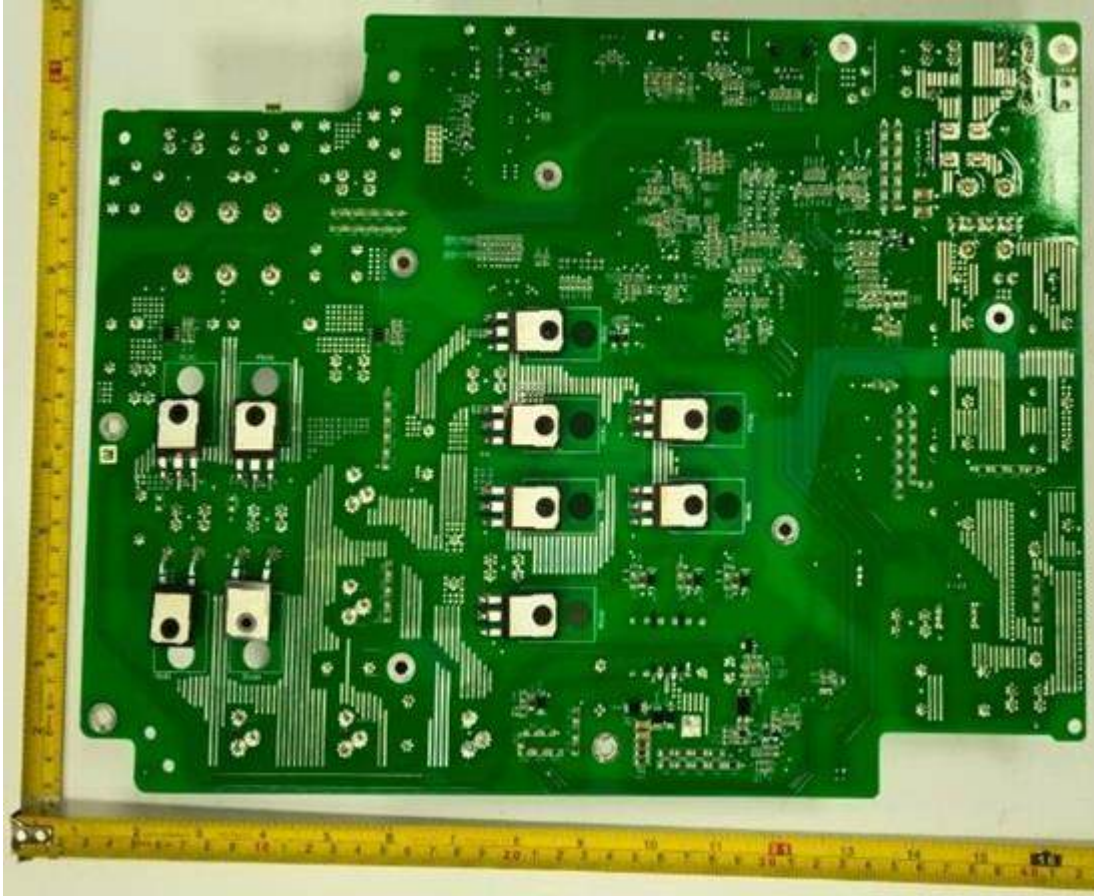

PCB Rear View

-----END OF THE REPORT-----

