



SUMMARY OF TEST REPORT

TEST REPORT NO: HPLI/Test/2204003401

DATE: 16/06/2022

(Number of Pages in Test Report: Page no. 1 to 28)

TEST FORMAT AS PER IS 16169: 2014/IEC 62116:2008

1. Name of the Manufacturer: **KSOLARE ENERGY PVT LTD.**
2. Product: Power Invertors for use in photovoltaic power system (Solar Grid Tied inverter)
3. Model: **KSY-22KW-3P (Representative model)**
KSY-20KW-3P, KSY-18KW-3P, KSY-15KW-3P, KSY-12KW-3P, KSY-10KW-3P,
KSY-8KW-3P, KSY-6KW-3P, KSY-5KW-3P, KSY-3KW-3P (**Series models**)
4. Model differences provided (if applicable): Yes
5. Model differences verified as per MNRE Guidelines for series formulation: Yes
6. Test Results:

SL. NO.	TEST REQUIREMENT	CLAUSE	VERDICT
1.	Test for single or multi-phase inverter	6.0	P
2.	Islanding as it applies to PV systems (Informative)	Annex A	P
3.	Test for independent islanding detection device	Annex B	N/A

General Information:

1. The conformity certificates of critical components are verified to ensure complete testing of apparatus under test and details regarding harmonized IEC standards (where IEC standards are not available) are also provided in the list of critical components.

CONCLUSION:

1. Sample meets all relevant requirements of IS 16169: 2014/IEC 62116:2008
2. ~~Sample fails to meet the following test requirements:~~

I, hereby undertake that the verdict stated in the test reports for all the test matches with the test results. The sample meets all relevant requirements of IS 16169:2014/IEC62116:2008 ~~does not meet the requirements stated above.~~

Date: 16/06/2022

HI PHYSIX LABORATORY INDIA PVT. LTD.
(Signature of Authorized person with Stamp)
[Signature]
(General Manager, Electronics Division)



TC-5100

TEST REPORT IS 16169: 2014/IEC 62116:2008 Test Procedure of Islanding Prevention Measures for Utility-Interconnected-Photovoltaic Inverters	
ULR-TC510022000000495F Discipline: Electronics Testing Group: Miscellaneous Products (Power Conversion Equipment)	
Report Reference No.....: HPLI/Test/2204003401 Date of issue.....: 16/06/2022 Total number of pages.....: 28	
Testing Laboratory.....: HI PHYSIX LABORATORY INDIA PRIVATE LIMITED Address: B-32/1/2, MIDC, RANJANGAON, PUNE, MAHARASHTRA, PIN-412220.	
Applicant's name.....:	KSOLARE ENERGY PVT LTD.
Address.....:	SR NO.62, HISSA NO. 3, MANGADEWADI, KATRAJ, PUNE SATARA ROAD, PUNE, MAHARASHTRA-411046
Test specification	
Standard	IS 16169: 2014/ IEC 62116:2008
Test procedure.....:	BIS Compliance Report
Non-standard test method	N/A
Test Report Form No.:	IS 16169:2014/IEC62116:2008_V1.0
Test Report Form Originator	BIS
MASTER TRF.....:	Dated: 05.04.2018
Test item description	Power Invertors for use in photovoltaic power system (Solar Grid Tied inverter)

HI PHYSIX LABORATORY INDIA PVT. LTD.

(General Manager - Electronics Division)





TC-5100

Trade mark	
Manufacturer	KSOLARE ENERGY PVT LTD.
Factory.....	SR NO.62, HISSA NO. 3, MANGADEVADI, KATRAJ, PUNE SATARA ROAD, PUNE, MAHARASTRA-411046
Model/Type reference.....	KSY-22KW-3P (Representative model) KSY-20KW-3P, KSY-18KW-3P, KSY-15KW-3P, KSY-12KW-3P, KSY-10KW-3P, KSY-8KW-3P, KSY-6KW-3P, KSY-5KW-3P, KSY-3KW-3P (Series models)
Ratings.....	DC Input: Max. input voltage: 1000Vdc, MPPT voltage range: 200-1000Vdc, Max. input current: 2*26A, Nominal DC input voltage: 620Vdc, Isc: 2*40A. AC Output: Vac: 400V, Fac nominal: 50Hz, Max. output current: 31.79A, Rated ac output power: 22000W, Operating Temp. range: -25 to 60°C (Representative model) (For Series model see copy of marking plate)

Testing procedure and testing location:

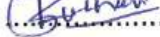
Testing Laboratory.....: HI PHYSIX LABORATORY INDIA PRIVATE LIMITED
Testing location/ address.....: B-32/1/2, MIDC, RANJANGAON, PUNE, MAHARASHTRA, PIN-412220.

Tested by (name + signature): Lalbahadur Chaudhari 

Reviewed & Approved by /
Authorized Signatory.....: Dr. M.N. Awatade 
(*Chief Engineer, Electronics Division*)

Issued by (Name+ signature):: K. K. Jayaswal 





TC-5100

ULR-TC510022000000495F

Page 3 of 28

Report No. HPLI/Test/2204003401

Summary of testing:	
Tests performed (name of test and test clause):	
All applicable tests	
Test for single or multi-phase inverter	6.0
Documentation	7.0
Unintentional Islanding	
Testing location:	
HI PHYSIX LABORATORY INDIA PRIVATE LIMITED	
B-32/1/2, MIDC, RANJANGAON, PUNE, MAHARASHTRA, PIN-412220.	

IS 16169/ IEC 62116_V1.0

HI PHYSIX LABORATORY INDIA PVT. LTD.

Dr. V. Awatade
(General Manager, Electronics Division)



TC-5100

Copy of marking plate of the equipment (Representative model)



5G-PRO
KSY-22KW-3P Solar GTI

Max. input voltage	1000Vdc
MPPT voltage range	200-1000V
Max. input current	2*26A
Nominal DC input voltage	620V
Isc PV	2*40A
Vac/Fac Nominal	400Vac/50Hz
Max. output current	31.78A
Rated AC output power	22000W
MFG Date	18/02/22
Power Factor	>0.99
Operating Temp. range	-25- +60 degree C
Deg. of protection	IP 65



SN: KSY0422HT0033

IEC61683,61727,60068,61727,61000,62109



KSOLARE ENERGY PVT. LTD.
SR NO 62, HISSA NO 3, MANGADEVADI,
KATRAJ PUNE SATARA ROAD, PUNE - 411046, INDIA
www.ksolare.com



5G-PRO
KSY-22KW-3P Solar GTI

Max. input voltage	1000Vdc
MPPT voltage range	200-1000V
Max. input current	2*26A
Nominal DC input voltage	620V
Isc PV	2*40A
Vac/Fac Nominal	400Vac/50Hz
Max. output current	31.78A
Rated AC output power	22000W
MFG Date	18/02/22
Power Factor	>0.99
Operating Temp. range	-25- +60 degree C
Deg. of protection	IP 65



SN: KSY0422HT0034

IEC61683,61727,60068,61727,61000,62109

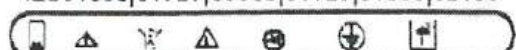

KSOLARE ENERGY PVT. LTD.
SR NO 62, HISSA NO 3, MANGADEVADI,
KATRAJ PUNE SATARA ROAD, PUNE - 411046, INDIA
www.ksolare.com



TC-5100

Copy of marking plate of series models



5G-PRO

KSY-20KW-3P Solar GTI

Max. input voltage	1000Vdc
MPPT voltage range	200-1000V
Max. input current	2*26A
Nominal DC input voltage	620V
Isc PV	2*40A
Vac/Fac Normal	400Vac/50Hz
Max. output current	28.8A
Rated AC output power	20000W
MFG Date	18/02/22
Power Factor	>0.99
Operating Temp. range	-25- +60 degree C
Deg. of protection	IP 65



SN: KSY0422HS0048

IEC61683,61727,60068,61727,61000,62109

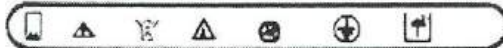

KSOLARE ENERGY PVT. LTD.
SR NO 52, HISSA NO 3, MANGADEWADI,
KATRAJ, PUNE SATARA ROAD, PUNE - 411045, INDIA
www.ksolare.com



5G-PRO

KSY-18KW-3P Solar GTI

Max. input voltage	1000Vdc
MPPT voltage range	200-1000V
Max. input current	2*26A
Nominal DC input voltage	620V
Isc PV	2*40A
Vac/Fac Normal	400Vac/50Hz
Max. output current	26.01A
Rated AC output power	18000W
MFG Date	18/02/22
Power Factor	>0.99
Operating Temp. range	-25- +60 degree C
Deg. of protection	IP 65



SN: KSY0422HS0047

IEC61683,61727,60068,61727,61000,62109



KSOLARE ENERGY PVT. LTD.
SR NO 52, HISSA NO 3, MANGADEWADI,
KATRAJ, PUNE SATARA ROAD, PUNE - 411045, INDIA
www.ksolare.com

HI PHYSIX LABORATORY INDIA PVT. LTD.
(Signature)
D. V. Awatade
(General Manager - Electronics Division)



TC-5100

Copy of marking plate of series models



5G-PRO
KSY-15KW-3P Solar GTI

Max. input voltage	1000Vdc
MPPT voltage range	200-1000V
Max. input current	2*26A
Nominal DC input voltage	620V
Isc PV	2*40A
Vac/Fac Normal	400Vac/50Hz
Max. output current	21.67A
Rated AC output power	15000W
MFG Date	18/02/22
Power Factor	>0.99
Operating Temp. range	-25- +60 degree C
Deg. of protection	IP 65



SN: KSY0422HS0045

IEC61683,61727,60068,61727,61000,62109

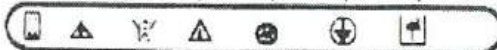

K SOLARE ENERGY PVT. LTD.
SR NO 52, HISSA NO 3, MANGADEWADI,
KATRAJ, PUNE SATARA ROAD, PUNE - 411045, INDIA
www.ksolare.com



5G-PRO
KSY-12KW-3P Solar GTI

Max. input voltage	1000Vdc
MPPT voltage range	200-1000V
Max. input current	2*13A
Nominal DC input voltage	620V
Isc PV	2*15A
Vac/Fac Normal	400Vac/50Hz
Max. output current	17.34A
Rated AC output power	12000W
MFG Date	18/02/22
Power Factor	>0.99
Operating Temp. range	-25- +60 degree C
Deg. of protection	IP 65



SN: KSY0422HS0044

IEC61683,61727,60068,61727,61000,62109

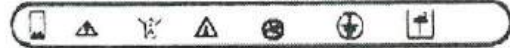

K SOLARE ENERGY PVT. LTD.
SR NO 52, HISSA NO 3, MANGADEWADI,
KATRAJ, PUNE SATARA ROAD, PUNE - 411045, INDIA
www.ksolare.com



TC-5100

Copy of marking plate of series models



5G-PRO

KSY-10KW-3P Solar GTI

Max. input voltage	1000Vdc
MPPT voltage range	200-1000V
Max. input current	2*13A
Nominal DC input voltage	620V
Isc PV	2*15A
Vac/Fac Normal	400Vac/50Hz
Max. output current	14.5A
Rated AC output power	10000W
MFG Date	18/02/22
Power Factor	>0.99
Operating Temp. range	-25- +60 degree C
Deg. of protection	IP 65



SN: KSY0422HS0043

IEC61683,61727,60068,61727,61000,62109

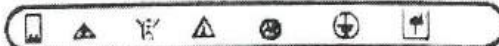

KSOLARE ENERGY PVT. LTD
SP NO 62, HISSA NO 3, MANGADEWADI,
KATRAJ, PUNE SATARA ROAD, PUNE - 411045, INDIA
www.ksolare.com



5G-PRO

KSY-8KW-3P Solar GTI

Max. input voltage	1000Vdc
MPPT voltage range	200-1000V
Max. input current	2*13A
Nominal DC input voltage	620V
Isc PV	2*15A
Vac/Fac Normal	400Vac/50Hz
Max. output current	11.56A
Rated AC output power	8000W
MFG Date	18/02/22
Power Factor	>0.99
Operating Temp. range	-25- +60 degree C
Deg. of protection	IP 65



SN: KSY0422HS0040

IEC61683,61727,60068,61727,61000,62109



KSOLARE ENERGY PVT. LTD
SP NO 62, HISSA NO 3, MANGADEWADI,
KATRAJ, PUNE SATARA ROAD, PUNE - 411045, INDIA
www.ksolare.com

(Signature)
S. Awatade
(General Manager - Electronics Division)



TC-5100

Copy of marking plate of series models



KSY-6KW-3P Solar GTI

Max. input voltage	1000Vdc
MPPT voltage range	200-1000V
Max. input current	2*13A
Nominal DC input voltage	620V
Isc PV	2*15A
Vac/Fac Normal	400Vac/50Hz
Max. output current	8.67A
Rated AC output power	6000W
MFG Date	18/02/22
Power Factor	>0.99
Operating Temp. range	-25- +60 degree C
Deg. of protection	IP 65



SN: KSY0422HS0038

IEC61683,61727,60068,61727,61000,62109



KSOLARE ENERGY PVT. LTD.
SR NO 52, HISSA NO 3, MANGADEWADI,
KATRAJ, PUNE SATARA ROAD, PUNE - 411046, INDIA
www.ksolare.com



KSY-5KW-3P Solar GTI

Max. input voltage	1000Vdc
MPPT voltage range	200-1000V
Max. input current	2*13A
Nominal DC input voltage	620V
Isc PV	2*15A
Vac/Fac Normal	400Vac/50Hz
Max. output current	7.22A
Rated AC output power	5000W
MFG Date	18/02/22
Power Factor	>0.99
Operating Temp. range	-25- +60 degree C
Deg. of protection	IP 65



SN: KSY0422HS0037

IEC61683,61727,60068,61727,61000,62109

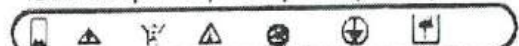

KSOLARE ENERGY PVT. LTD.
SR NO 52, HISSA NO 3, MANGADEWADI,
KATRAJ, PUNE SATARA ROAD, PUNE - 411046, INDIA
www.ksolare.com

(Signature)
Mangade
(General Manager - Electronics Division)



TC-5100

Copy of marking plate of series model



5G-PRO

KSY-3KW-3P Solar GTI

Max. input voltage	1000Vdc
MPPT voltage range	200-1000V
Max. input current	2*13A
Nominal DC input voltage	620V
Isc PV	2*15A
Vac/Fac Normal	400Vac/50Hz
Max. output current	4.3A
Rated AC output power	3000W
MFG Date	18/02/22
Power Factor	>0.99
Operating Temp. range	-25- +60 degree C
Deg. of protection	IP 65

SN: KSY0422HS0035

IEC61683,61727,60068,61727,61000,62109

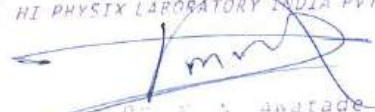

KSOLARE ENERGY PVT. LTD.
SR NO 52, HISSA NO 3 MANGADEWADI,
KATRAJ PUNE SATARA ROAD PUNE - 411045, INDIA
www.ksolare.com

HI PHYSIX LABORATORY INDIA PVT. LTD.

General Manager - Electronics Division



TC-5100

<p>Test case verdicts</p> <p>Test case does not apply to the test object: N/A</p> <p>Test item does meet the requirement.....: P(Pass)</p> <p>Test item does not meet the requirement.....: F(Fail)</p>
<p>Testing</p> <p>Date of receipt of test item.....: 13-04-2022</p> <p>Date(s) of performance of test.....: 25-04-2022 to 14/06/2022</p>

GENERAL INFORMATION	
Test item particulars:	See below
Accessories and detachable parts included in the evaluation	N/A
Options included	N/A
Abbreviations used in the report	See below
EUT – Equipment Under Test	MPPT – Maximum Power Point Tracking
Qf – Quality factor	W - Utility Real Power
Var – Utility Reactive Power	VDC – DC Voltage
VEUT – AC Voltage of EUT	tR – Run on time
IR – Resistive load current	IL – Inductive load current
IC – Capacitive load current	PAC – Utility Real Power
QAC – Utility Reactive Power	IAC – Utility Current
Possible test case verdicts:	N/A
test case does not apply to the test object	
test object does meet the requirement	Pass (P)
test object does not meet the requirement	Fail (F)

HI PHYSIX LABORATORY INDIA PVT. LTD.

 P. V. Awatade
 (General Manager - Electronics Division)



TC-5100

Manufacturer's Declaration per Standard:

Similarities between the models:

- 1) Same rated Input/ Output voltage: 620VDC/400VAC
- 2) Same frequency: 50Hz
- 3) Number of Phases at output: Three-phase
- 4) Same PCB design and layout: Same
- 5) Same Power Stage topology: Non-isolated
- 6) Same Insulation Class: Transformer less
- 7) Same Control Algorithm/firmware: V1.0, Firmware Version Name: Ver 1.0, Hardware Version Name: KSY
- 8) Same Cabinet Design: IP65
- 9) Class of construction: Class II

Differences between the models:

Model description, Electrical rating (as mentioned in marking plate), Dimensions & weight.

General remarks:

The test results presented in this report relate only to the object tested.
This report shall not be reproduced except in full, without the written approval of the Issuing testing laboratory.
The Management System is maintained in accordance with IS/ISO/IEC 17025:2017 and testing Standards/Instruments are traceable to National / International Standards.
"(See Enclosure #)" refers to additional information appended to the report.
"(See appended table)" refers to a table appended to the report.
Throughout this report a point is used as the decimal separator.



TC-5100

General Product Information:
Product Electrical Ratings

Parameter	Value		Remarks
1) Rating			
a) Maximum output power	W	22000	---
b) DC voltage range	Vdc	200-1000Vdc	---
c) DC current limits	Idc	2*26Adc	---
d) AC voltage range	Vac	400Vac	---
e) Frequency range	Hz	50Hz	---
f) AC current limits	A	31.79Aac	---
g) Efficiency	%	98.2%	---
h) Voltage trip settings (magnitude and timing)	V	195.5 (each phase relative to the Neutral Line) <2s (Under voltage) 254 (each phase relative to the Neutral Line) <2s (over voltage)	---
i) Frequency trip settings (magnitude and timing)	Hz	48.5 (Under frequency) for <1s 50.5 (Over frequency) for <1s	---
i) Other software settings	---	Refer user manual	---
j) Firmware version	---	V1.0, Firmware Version Name: Ver 1.0, Hardware Version Name: KSY	---
2) Others	---	---	---
a) Displays	---	LED with LCD display	---
b) Temperature range	°C	-25°C to +60°C	---
c) Humidity	%	0% to 100%	---
Sample code by online request is "SC22SPI00246"			

IS 16169/ IEC 62116_V1.0

HI PHYSIX LABORATORY INDIA PVT. LTD.
(Signature)
Awatade
(General Manager - Electronics Division)



TC-5100

IS 16169:2014 /IEC 62116:2008			
Clause	Requirement + Test	Result – Remark	Verdict
4	Testing circuit	See below	P
	The testing circuit shown in Figure 1 is employed.	See below	P
	Similar circuits are used for three-phase output.	Three-phase output	P
	Parameters to be measured are shown in Table 1 and Figure 1. Parameters to be recorded in the test report are discussed in Clause 7.	Parameters measured according to clause 7 and recorded in the test report	P
5	Testing equipment	See below	P
5.1	Measuring instruments	See below	P
	The waveform measurement/capture device is able to record the waveform from the beginning of the islanding test until the EUT ceases to energize the island.	For waveform measurement digital oscilloscope is used.	P
	For multi-phase EUT, all phases are monitored.	Three phase EUT & all phases monitored	P
	A waveform monitor designed to detect and calculate the run-on time may be used.	Complies	P
	For multi-phase EUT, the test and measurement equipment is recorded each phase current and each phase-to-neutral or phase-to-phase voltage, as appropriate, to determine fundamental frequency active and reactive power flow over the duration of the test.	Complies	P
	A sampling rate of 10 kHz or higher is recommended. The minimum measurement accuracy is 1 % or less of rated EUT nominal output voltage and 1 % or less of rated EUT output current	Complies	P
	Current, active power, and reactive power measurements through switch S1 used to determine the circuit balance conditions report the fundamental (50 Hz or 60 Hz) component.	Complies	P
5.2	DC power source	See below	P
5.2.1	General	See below	P
	A PV array or PV array simulator (preferred) may be used. If the EUT can operate in utility- interconnected mode from a storage battery, a DC power source may be used in lieu of a battery as long as the DC power source is not the limiting device as far as the maximum EUT input current is concerned.	PV array simulator is used	P

IS 16169/ IEC 62116_V1.0

HI PHYSIX LABORATORY INDIA PVT. LTD.
(Signature)
Grade
(Generator Electronics Division)



TC-5100

IS 16169:2014 /IEC 62116:2008			
Clause	Requirement + Test	Result – Remark	Verdict
	The DC power source provides voltage and current necessary to meet the testing requirements described in Clause 6.	Complies	P
5.2.2	PV array simulator	See below	P
	The tests are conducted at the input voltage defined in Table 2 below, and the current is limited to 1.5 times the rated photovoltaic input current, except when specified otherwise by the test requirements.	Complies	P
	A PV array simulator is recommended, however, any type of power source may be used if it does not influence the test results.	PV array simulator is used	P
5.2.3	Current and voltage limited DC power supply with series resistance	Array simulator is used	N/A
	A DC power source used as the EUT input source is capable of EUT maximum input power (so as to achieve EUT maximum output power) at minimum and maximum EUT input operating voltage.	See above	N/A
	The power source provides adjustable current and voltage limit, set to provide the desired short circuit current and open circuit voltage when combined with the series and shunt resistance described below.	See above	N/A
	A series resistance (and, optionally, a shunt resistance) is selected to provide a fill factor within the range: Output power: Sufficient to provide maximum EUT output power and other levels specified by test conditions of table 5. Response speed: The response time of a simulator to a step in output voltage, due to a 5% load change, results in a settling of the output current to within 10% of its final value in less than 1ms. Stability: Excluding the variations caused by the EUT MPPT, simulator output power remains stable within 2 % of specified power level over the duration of the test: from the point where load balance is achieved until the island condition is cleared or the allowable run-on time is exceeded. Power factor: 0.25 to 0.8	See above	N/A
5.2.4	PV array	Array simulator is used	N/A

IS 16169/ IEC 62116_V1.0

HI PHYSIX LABORATORY INDIA PVT. LTD.
(Signature)
S. Awatade
(General Manager - Electronics Division)



TC-5100

IS 16169:2014 /IEC 62116:2008				
Clause	Requirement + Test	Result – Remark	Verdict	
	A PV array used as the EUT input source is capable of EUT maximum input power at minimum and maximum EUT input operating voltage.	See above	N/A	
	Testing is limited to times when the irradiance varies by no more than 2 % over the duration of the test as measured by a silicon-type pyranometer or reference device. It may be necessary to adjust the array configuration to achieve the input voltage and power levels prescribed in 6.1.	See above	N/A	
5.3	AC power source			
	The utility grid or other AC power source may be used as long as it meets the conditions specified in Table 4.	Meets the conditions specified in Table 4.	P	
	Table 4 – AC power source requirements			
	Items			Conditions
	Voltage			Nominal $\pm 2.0\%$
	Voltage THD			<2.5%
	Frequency			Nominal ± 1 Hz
	Phase angle distance ¹⁾			
	¹⁾ Three-phase case only			
5.4	AC loads	See below	P	
	On the AC side of the EUT, variable resistance, capacitance, and inductance are connected in parallel as loads between the EUT and the AC power source. Other sources of load, such as electronic loads, may be used if it can be shown that the source does not cause results that are different than would be obtained with passive resistors, inductors, and capacitors.	Variable RLC (AC)load used	P	
	All AC loads are rated for and adjustable to all test conditions. The equations for Qf are based upon an ideal parallel RLC circuit. For this reason, non- inductive resistors, low loss (high Qf) inductors, and capacitors with low effective series resistance and effective series inductance are utilized in the test circuit. Iron core inductors, if used, are not exceed a current THD of 2 % when operated at nominal voltage. Load components are conservatively rated for the voltage and power levels expected. Resistor power ratings are chosen so as to minimize thermally-induced drift in Resistance values during the course of the test.	Meeting the requirement	P	

IS 16169/ IEC 62116_V1.0

HI PHYSIX LABORATORY INDIA PVT. LTD.
(Signature)
awarade
(General Manager - Electronics Division)



TC-5100

IS 16169:2014 /IEC 62116:2008			
Clause	Requirement + Test	Result – Remark	Verdict
	Active and reactive power is calculated (using the measurements provided in Table 1) in each of the R, L and C legs of the load so that these parasitic parameters (and parasitics introduced by variacs or autotransformers) are properly accounted for when calculating Qf	Complies	P
6	Test for single or multi-phase inverter	See below	P
6.1	Test procedure	See below	P
	The test uses an RLC load, resonant at the EUT nominal frequency (50 Hz or 60 Hz) and matched to the EUT output power.	Variable RLC (AC) load used*	P
	For multi-phase EUT, the load is balanced across all phases and the switch S1 as in Figure 1 opens all phases	Complies	P
	This test is performed with the EUT conditions as in Table 5, where power and voltage values are given as a percent of EUT full output rating.	See below	P
	a) Determine EUT test output power	See appended table 6.1	P
	b) Adjusting the DC input source	See appended table 6.1	P
	c) Turn off the EUT and open S1	See appended table 6.1	P
	d) Adjust the RLC circuit to have $Q_f = 1.0 \pm 0.05$	See appended table 6.1	P
	e) Connect the RLC load configured in step d) to the EUT by closing S2	See appended table 6.1	P
	f) Open the utility-disconnect switch S1 to initiate the test, Run-on time is recorded.	See appended table 6.1	P
	g) For test condition A, adjust the real load and only one of the reactive load components to each of the load imbalance conditions shown in the shaded portion of table 6. If any of the recorded run-on times are longer than the one recorded for the rated balance condition, then the non-shaded parameter combinations also Require testing.	See appended table 6.1	P
	h) For test condition B and C, adjust the only one reactive load components by approximately 1.0% per test, within a total range of 95% to 105% of the operating point. If run-on times are still increasing at the 95% or 105% points, additional 1% increments have to be taken until run-on times begin decreasing.	See appended table 6.1	P
6.2	Pass/fail criteria	See below	P

IS 16169/ IEC 62116_V1.0

HI PHYSIX LABORATORY INDIA PVT. LTD.
[Signature]
M. S. S. Awasthi
(General Manager, Quality Assurance Division)



TC-5100

IS 16169:2014 /IEC 62116:2008			
Clause	Requirement + Test	Result – Remark	Verdict
	An EUT is considered to comply with the requirements for islanding protection when each case of recorded run-on time is less than 2 s or meets the requirements of local codes.	See appended table 6.1	P
7	Documentation	See below	P
	At a minimum, the following information is recorded and maintained in the test report.	See below	P
	a) Specifications of EUT. Table 8 provides an example of the type of information that is provided.	See attached data sheet on page no. 27	P
	b) Measurement results. Table 9 provides an example of the type of information that is provided. Actual measured values are to be recorded.	See appended table 6.1	P
	c) Block diagram of test circuit.	See page no. 28	P
	d) Specifications of the test and measurement equipment. Table 10 provides an example of the type of information that is provided.	Complies	P
	e) Any test configuration or procedure details such as methods of achieving specified load and EUT output conditions.	Complies	P
	f) Any additional information required by the testing laboratory's accreditation.	Nil	N/A
	g) Specify the evaluation criterion from clause 6.2 that was utilized to determine if the product passed or failed the test.	Comply with the criteria	P
Annex A	Islanding as it applies to PV systems(Informative)	Complies	P
A.1	General	See above Annex A	P
A.2	Impact of distortion on islanding	See above Annex A	P
Annex B	Test for independent islanding detection device (relay)(Informative)	No such application	N/A
B.1	Introduction	See above	N/A
B.2	Testing circuit	See above	N/A
B.3	Testing equipment	See above	N/A
B.4	Testing procedure	See above	N/A
B.5	Documentation	See above	N/A

IS 16169/ IEC 62116_V1.0

HI PHYSIX LABORATORY INDIA PVT. LTD.

 M. Awatade
 (Electronics Division)



TC-5100

IS 16169:2014 /IEC 62116:2008

Clause	Requirement + Test	Result – Remark	Verdict
--------	--------------------	-----------------	---------

6.1 Table: Tested condition and run-on time												
Sr. No.	P _{EUT} (% of EUT rating)	Reactive load (% of Q _L)	P _{AC} (% of nominal)	Q _{AC} (% of nominal)	Run on time (ms)	P _{EUT} (KW)	Pr (Resistive) (W)	PI (Inductive) (Var)	Pc (Capacitive) (Var)	Actual Q _f	VD C	Remarks
1	100	100	0	0	396.0	22.00	L1:7351 L2:7356 L3:7366	L1:7376 L2:7404 L3:7399	L1:7336 L2:7340 L3:7348	L1: 1.000 L2: 1.000 L3: 1.000	740	Test A at BL
2	66	66	0	0	284.0	14.52	L1:4851 L2:4856 L3:4874	L1:4896 L2:4879 L3:4897	L1:4811 L2:4854 L3:4854	L1:1.001 L2:1.002 L3:1.000	500	Test B at BL
3	33	33	0	0	206.0	7.26	L1:2426 L2:2434 L3:2455	L1:2481 L2:2487 L3:2488	L1:2387 L2:2413 L3:2425	L1:1.003 L2:1.006 L3:1.001	260	Test C at BL
4	100	100	-5	-5	340.0	22.00	L1:7718 L2:7724 L3:7734	L1:7745 L2:7771 L3:7769	L1:7736 L2:7340 L3:7348	L1:0.976 L2:0.978 L3:0.976	740	Test A at IB
5	100	100	-5	0	366.0	22.00	L1:7673 L2:7663 L3:7673	L1:7376 L2:7401 L3:7399	L1:7336 L2:7340 L3:7348	L1:0.959 L2:0.962 L3:0.961	740	Test A at IB
6	100	100	-5	5	377.0	22.00	L1:7696 L2:7685 L3:7701	L1:7007 L2:7031 L3:7029	L1:7336 L2:7340 L3:7348	L1:0.932 L2:0.935 L3:0.933	740	Test A at IB
7	100	100	0	-5	350.0	22.00	L1:7351 L2:7356 L3:7366	L1:7740 L2:7760 L3:7758	L1:7336 L2:7340 L3:7348	L1:1.025 L2:1.026 L3:1.025	740	Test A at IB
8	100	100	0	5	371.0	22.00	L1:7351 L2:7356 L3:7366	L1:6997 L2:7021 L3:7021	L1:7336 L2:7340 L3:7348	L1:0.974 L2:0.975 L3:0.974	740	Test A at IB
9	100	100	5	-5	370.0	22.00	L1:6983 L2:6988 L3:6997	L1:7715 L2:7743 L3:7740	L1:7336 L2:7340 L3:7348	L1:1.077 L2:1.079 L3:1.078	740	Test A at IB
10	100	100	5	0	365.0	22.00	L1:6976 L2:6976 L3:6985	L1:7376 L2:7401 L3:7399	L1:7336 L2:7340 L3:7348	L1:1.054 L2:1.057 L3:1.056	740	Test A at IB
11	100	100	5	5	368.0	22.00	L1:6981 L2:6980 L3:6996	L1:7012 L2:7031 L3:7037	L1:7336 L2:7340 L3:7348	L1:1.027 L2:1.029 L3:1.028	740	Test A at IB
12	100	100	-10	10	373.0	22.00	L1:7786 L2:7796 L3:7813	L1:6843 L2:6879 L3:6897	L1:7336 L2:7340 L3:7348	L1:0.910 L2:0.910 L3:0.911	740	Test A at IB
13	100	100	-5	10	379.0	22.00	L1:7657 L2:7644 L3:7647	L1:6868 L2:6904 L3:6936	L1:7336 L2:7340 L3:7348	L1:0.927 L2:0.931 L3:0.934	740	Test A at IB

HI PHYSIX LABORATORY INDIA PVT. LTD.

(Signature)
Dr. S. S. Awastade
(General Manager, Electronics Division)

IS 16169/ IEC 62116_V1.0



TC-5100

IS 16169:2014 /IEC 62116:2008												
Clause	Requirement + Test						Result – Remark				Verdict	
14	100	100	0	10	383.0	22.00	L1:7362 L2:7367 L3:7384	L1:6859 L2:6897 L3:6926	L1:7336 L2:7340 L3:7348	L1:0.964 L2:0.966 L3:0.966	740	Test A at IB
15	100	100	10	10	333.0	22.00	L1:6601 L2:6601 L3:6604	L1:6654 L2:6680 L3:6690	L1:7336 L2:7340 L3:7348	L1:1.058 L2:1.061 L3:1.062	740	Test A at IB
16	100	100	10	5	387.0	22.00	L1:6627 L2:6632 L3:6643	L1:7033 L2:7056 L3:7067	L1:7336 L2:7340 L3:7348	L1:1.084 L2:1.085 L3:1.085	740	Test A at IB
17	100	100	10	0	355.0	22.00	L1:6608 L2:6608 L3:6628	L1:7376 L2:7401 L3:7399	L1:7336 L2:7340 L3:7348	L1:1.113 L2:1.115 L3:1.112	740	Test A at IB
18	100	100	10	-5	359.0	22.00	L1:6619 L2:6622 L3:6647	L1:7715 L2:7743 L3:7740	L1:7336 L2:7340 L3:7348	L1:1.137 L2:1.138 L3:1.134	740	Test A at IB
19	100	100	10	-10	369.0	22.00	L1:6591 L2:6593 L3:6626	L1:7698 L2:7740 L3:7684	L1:7336 L2:7340 L3:7348	L1:1.140 L2:1.143 L3:1.134	740	Test A at IB
20	100	100	5	-10	330.0	22.00	L1:7066 L2:7071 L3:7096	L1:7713 L2:7758 L3:7715	L1:7336 L2:7340 L3:7348	L1:1.065 L2:1.067 L3:1.061	740	Test A at IB
21	100	100	0	-10	364.0	22.00	L1:7351 L2:7356 L3:7366	L1:7701 L2:7743 L3:7708	L1:7336 L2:7340 L3:7348	L1:1.023 L2:1.025 L3:1.022	740	Test A at IB
22	100	100	-5	-10	341.0	22.00	L1:7687 L2:7679 L3:7692	L1:7718 L2:7762 L3:7733	L1:7336 L2:7340 L3:7348	L1:0.979 L2:0.983 L3:0.980	740	Test A at IB
23	100	100	-10	-10	337.0	22.00	L1:7801 L2:7815 L3:7838	L1:7703 L2:7743 L3:7724	L1:7336 L2:7340 L3:7348	L1:0.964 L2:0.965 L3:0.961	740	Test A at IB
24	100	100	-10	-5	328.0	22.00	L1:7762 L2:7773 L3:7773	L1:7731 L2:7760 L3:7765	L1:7336 L2:7340 L3:7348	L1:0.970 L2:0.971 L3:0.972	740	Test A at IB
25	100	100	-10	0	324.0	22.00	L1:7733 L2:7746 L3:7741	L1:7376 L2:7401 L3:7399	L1:7336 L2:7340 L3:7348	L1:0.951 L2:0.951 L3:0.952	740	Test A at IB
26	100	100	-10	5	319.0	22.00	L1:7697 L2:7709 L3:7692	L1:7068 L2:7087 L3:7112	L1:7336 L2:7340 L3:7348	L1:0.936 L2:0.936 L3:0.940	740	Test A at IB
27	66	66	0	-5	258.0	14.52	L1:4851 L2:4856 L3:4874	L1:5143 L2:5131 L3:5156	L1:4811 L2:4854 L3:4854	L1:1.025 L2:1.028 L3:1.026	500	Test B at IB

IS 16169/ IEC 62116_V1.0

HI PHYSIX LABORATORY INDIA PVT. LTD.
(Signature)
Awatade
(General Manager - Electronics Division)



TC-5100

IS 16169:2014 /IEC 62116:2008

Clause	Requirement + Test						Result – Remark				Verdict	
28	66	66	0	-4	236.0	14.52	L1:4851 L2:4856 L3:4874	L1:5092 L2:5075 L3:5093	L1:4811 L2:4854 L3:4854	L1:1.020 L2:1.022 L3:1.020	500	Test B at IB
29	66	66	0	-3	233.0	14.52	L1:4851 L2:4856 L3:4874	L1:5043 L2:5026 L3:5044	L1:4811 L2:4854 L3:4854	L1:1.015 L2:1.017 L3:1.015	500	Test B at IB
30	66	66	0	-2	230.0	14.52	L1:4851 L2:4856 L3:4874	L1:4994 L2:4977 L3:4995	L1:4811 L2:4854 L3:4854	L1:1.010 L2:1.012 L3:1.010	500	Test B at IB
31	66	66	0	-1	239.0	14.52	L1:4851 L2:4856 L3:4874	L1:4945 L2:4928 L3:4946	L1:4811 L2:4854 L3:4854	L1:1.005 L2:1.007 L3:1.005	500	Test B at IB
32	66	66	0	1	245.0	14.52	L1:4851 L2:4856 L3:4874	L1:4848 L2:4831 L3:4849	L1:4811 L2:4854 L3:4854	L1:0.995 L2:0.997 L3:0.995	500	Test B at IB
33	66	66	0	2	255.0	14.52	L1:4851 L2:4856 L3:4874	L1:4799 L2:4782 L3:4800	L1:4811 L2:4854 L3:4854	L1:0.990 L2:0.992 L3:0.990	500	Test B at IB
34	66	66	0	3	261.0	14.52	L1:4851 L2:4856 L3:4874	L1:4750 L2:4733 L3:4751	L1:4811 L2:4854 L3:4854	L1:0.985 L2:0.987 L3:0.985	500	Test B at IB
35	66	66	0	4	243.0	14.52	L1:4851 L2:4856 L3:4874	L1:4701 L2:4684 L3:4702	L1:4811 L2:4854 L3:4854	L1:0.980 L2:0.982 L3:0.980	500	Test B at IB
36	66	66	0	5	249.0	14.52	L1:4851 L2:4856 L3:4874	L1:4652 L2:4636 L3:4653	L1:4811 L2:4854 L3:4854	L1:0.975 L2:0.977 L3:0.975	500	Test B at IB
37	33	33	0	-5	150.0	7.26	L1:2426 L2:2434 L3:2455	L1:2605 L2:2611 L3:2612	L1:2387 L2:2413 L3:2425	L1:1.028 L2:1.031 L3:1.025	260	Test C at IB
38	33	33	0	-4	195.0	7.26	L1:2426 L2:2434 L3:2455	L1:2580 L2:2586 L3:2587	L1:2387 L2:2413 L3:2425	L1:1.023 L2:1.026 L3:1.020	260	Test C at IB
39	33	33	0	-3	222.0	7.26	L1:2426 L2:2434 L3:2455	L1:2555 L2:2561 L3:2562	L1:2387 L2:2413 L3:2425	L1:1.018 L2:1.021 L3:1.015	260	Test C at IB
40	33	33	0	-2	215.0	7.26	L1:2426 L2:2434 L3:2455	L1:2530 L2:2536 L3:2537	L1:2387 L2:2413 L3:2425	L1:1.013 L2:1.016 L3:1.010	260	Test C at IB
41	33	33	0	-1	211.0	7.26	L1:2426 L2:2434 L3:2455	L1:2506 L2:2512 L3:2513	L1:2387 L2:2413 L3:2425	L1:1.008 L2:1.011 L3:1.006	260	Test C at IB
42	33	33	0	1	214.0	7.26	L1:2426 L2:2434 L3:2455	L1:2456 L2:2462 L3:2463	L1:2387 L2:2413 L3:2425	L1:0.998 L2:1.001 L3:0.996	260	Test C at IB

IS 16169/ IEC 62116_V1.0

HI PHYSIX TESTING & CALIBRATION LAB. LTD.
(Signature)
Electronics Division



TC-5100

ULR-TC510022000000495F

Page 21 of 28

Report No. HPLI/Test/2204003401

IS 16169:2014 /IEC 62116:2008

Clause	Requirement + Test						Result – Remark				Verdict
--------	--------------------	--	--	--	--	--	-----------------	--	--	--	---------

43	33	33	0	2	235.0	7.26	L1:2426 L2:2434 L3:2455	L1:2431 L2:2437 L3:2438	L1:2387 L2:2413 L3:2425	L1:0.993 L2:0.996 L3:0.990	260	Test C at IB
44	33	33	0	3	205.0	7.26	L1:2426 L2:2434 L3:2455	L1:2406 L2:2412 L3:2413	L1:2387 L2:2413 L3:2425	L1:0.988 L2:0.991 L3:0.985	260	Test C at IB
45	33	33	0	4	197.0	7.26	L1:2426 L2:2434 L3:2455	L1:2382 L2:2387 L3:2388	L1:2387 L2:2413 L3:2425	L1:0.983 L2:0.986 L3:0.980	260	Test C at IB
46	33	33	0	5	195.0	7.26	L1:2426 L2:2434 L3:2455	L1:2357 L2:2362 L3:2363	L1:2387 L2:2413 L3:2425	L1:0.978 L2:0.981 L3:0.975	260	Test C at IB

a PEUT: EUT output power.

b PAC: Active power flow at S1 in figure 1. Positive means power from EUT to utility. Nominal is the 0% test condition value.

c QAC: Reactive power flow at S1 in figure 1. Positive means power from EUT to utility. Nominal is the 0% test condition value.

D BL: balance condition, IB: imbalance condition.

HI PHYSIX LABORATORY INDIA PVT. LTD.
[Signature]
General Manager - Electronics Division

IS 16169/ IEC 62116_V1.0



TC-5100

ULR-TC510022000000495F

Page 22 of 28

Report No. HPLI/Test/2204003401

IS 16169:2014 / IEC 62116:2008			
Clause	Requirement + Test	Result – Remark	Verdict

Appendix A

Photograph

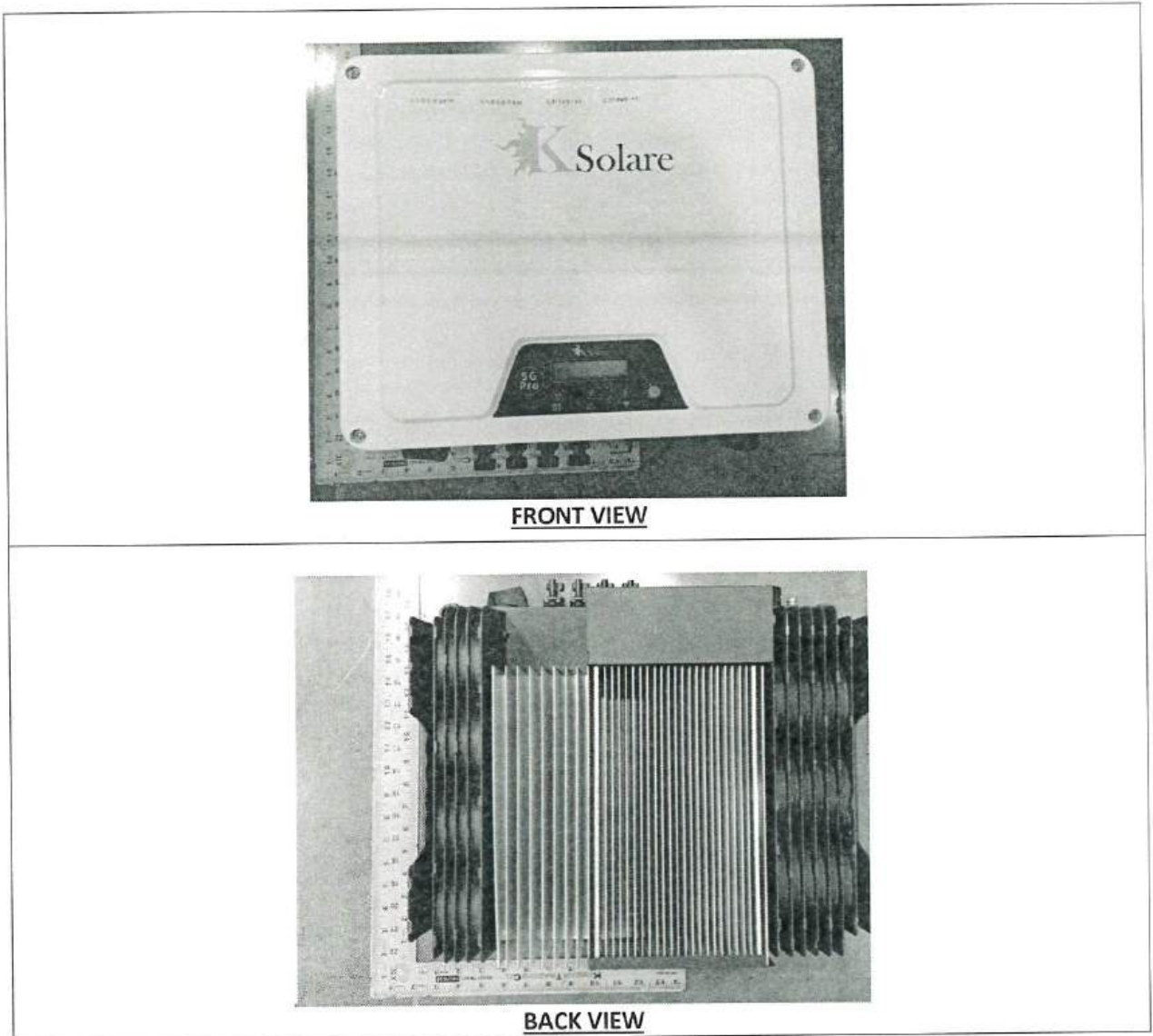

FRONT VIEW

BACK VIEW

IS 16169/ IEC 62116_V1.0

HI PHYSIX LABORATORY INDIA PVT. LTD.

 Anirudh Awatade
 (General Manager - Electronics Division)



TC-5100

ULR-TC510022000000495F

Page 23 of 28

Report No. HPLI/Test/2204003401

IS 16169:2014 /IEC 62116:2008			
Clause	Requirement + Test	Result – Remark	Verdict

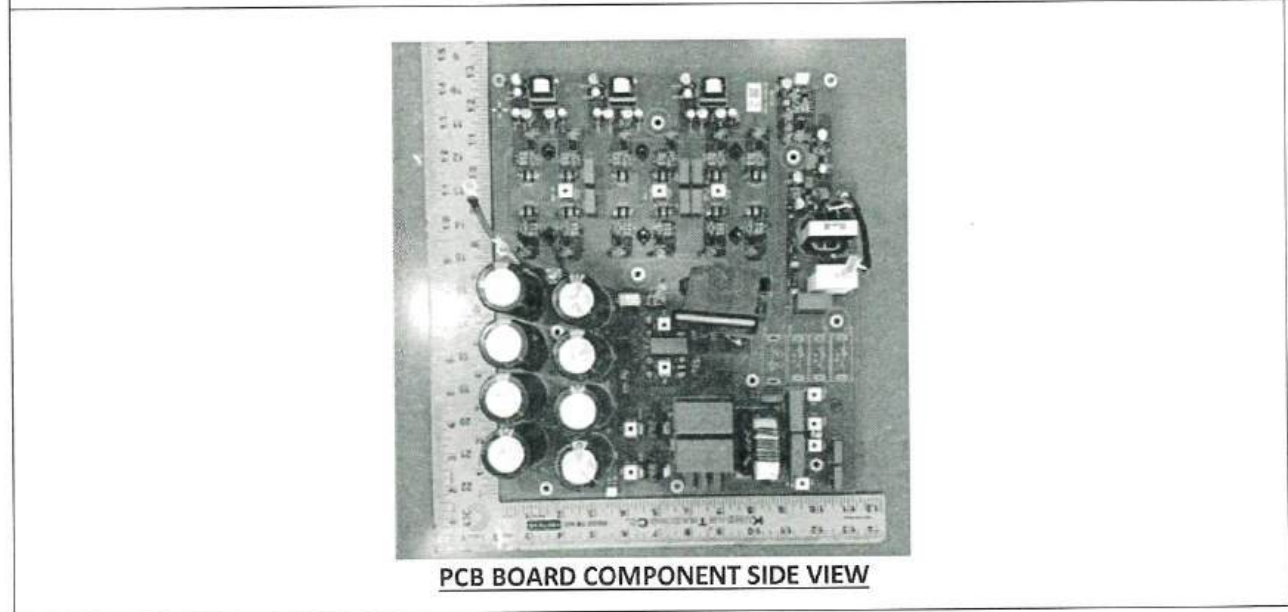
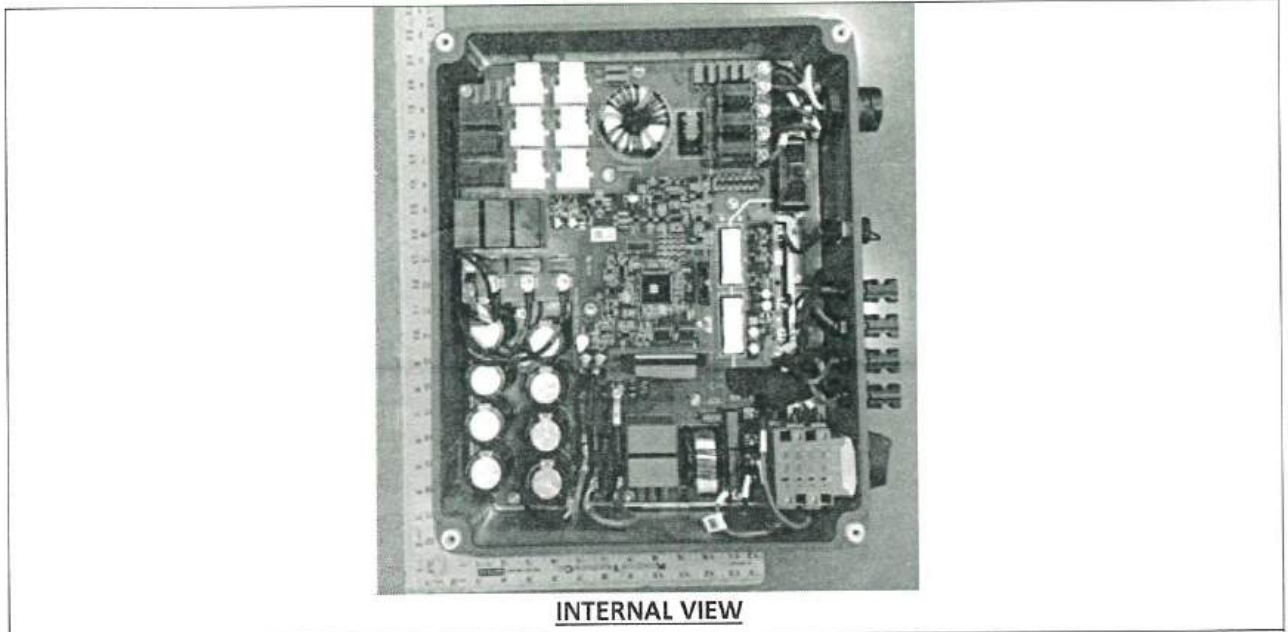

IS 16169/ IEC 62116_V1.0

HI PHYSIX LABORATORY INDIA PVT. LTD.

 Anirade
 (General Manager - Electronics Division)

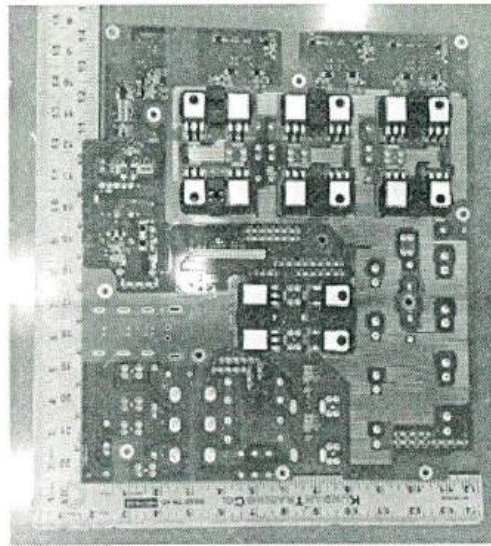

TC-5100

IS 16169:2014 /IEC 62116:2008			
Clause	Requirement + Test	Result – Remark	Verdict



PCB BOARD SOLDER SIDE VIEW

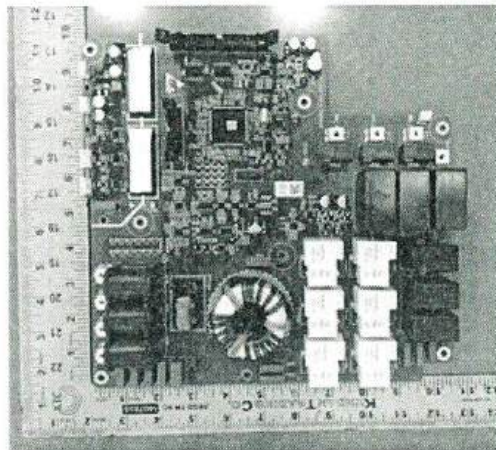

PCB BOARD COMPONENT SIDE VIEW

IS 16169/ IEC 62116_V1.0

HI PHYSIX LABORATORY INDIA PVT. LTD.

[Signature]
B. N. S. Awasthi
(General Manager - Electronics Division)



TC-5100

ULR-TC510022000000495F

Page 25 of 28

Report No. HPLI/Test/2204003401

IS 16169:2014 /IEC 62116:2008			
Clause	Requirement + Test	Result – Remark	Verdict

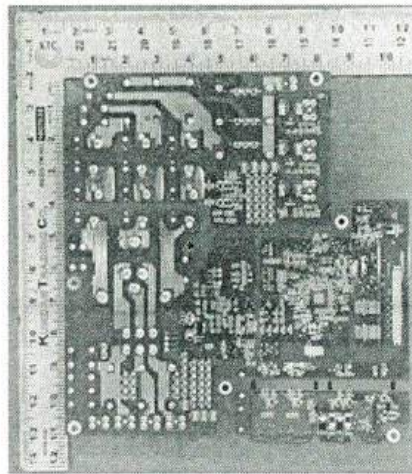

PCB BOARD SOLDER SIDE VIEW

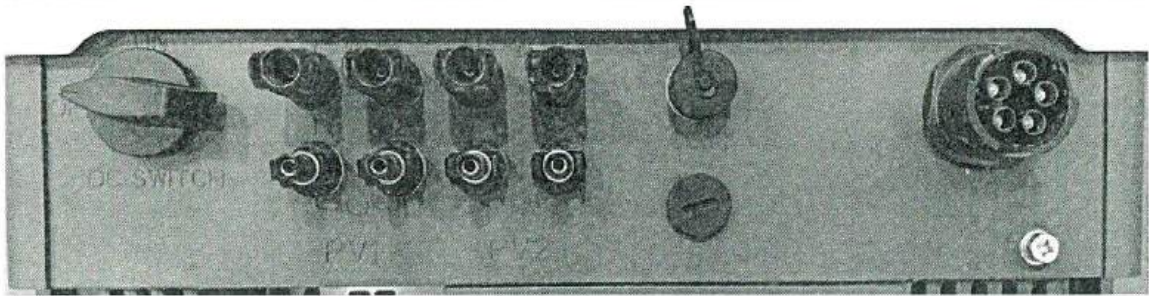

DC SWITCH, PV CONNECTOS, COM PORT AND AC OUTPUT PORT

IS 16169/ IEC 62116_V1.0

HI PHYSIX LABORATORY INDIA PVT. LTD.
[Signature]
Awatade
(General Manager - Electronics Division)



TC-5100

IS 16169:2014 /IEC 62116:2008			
Clause	Requirement + Test	Result - Remark	Verdict

Waveforms:

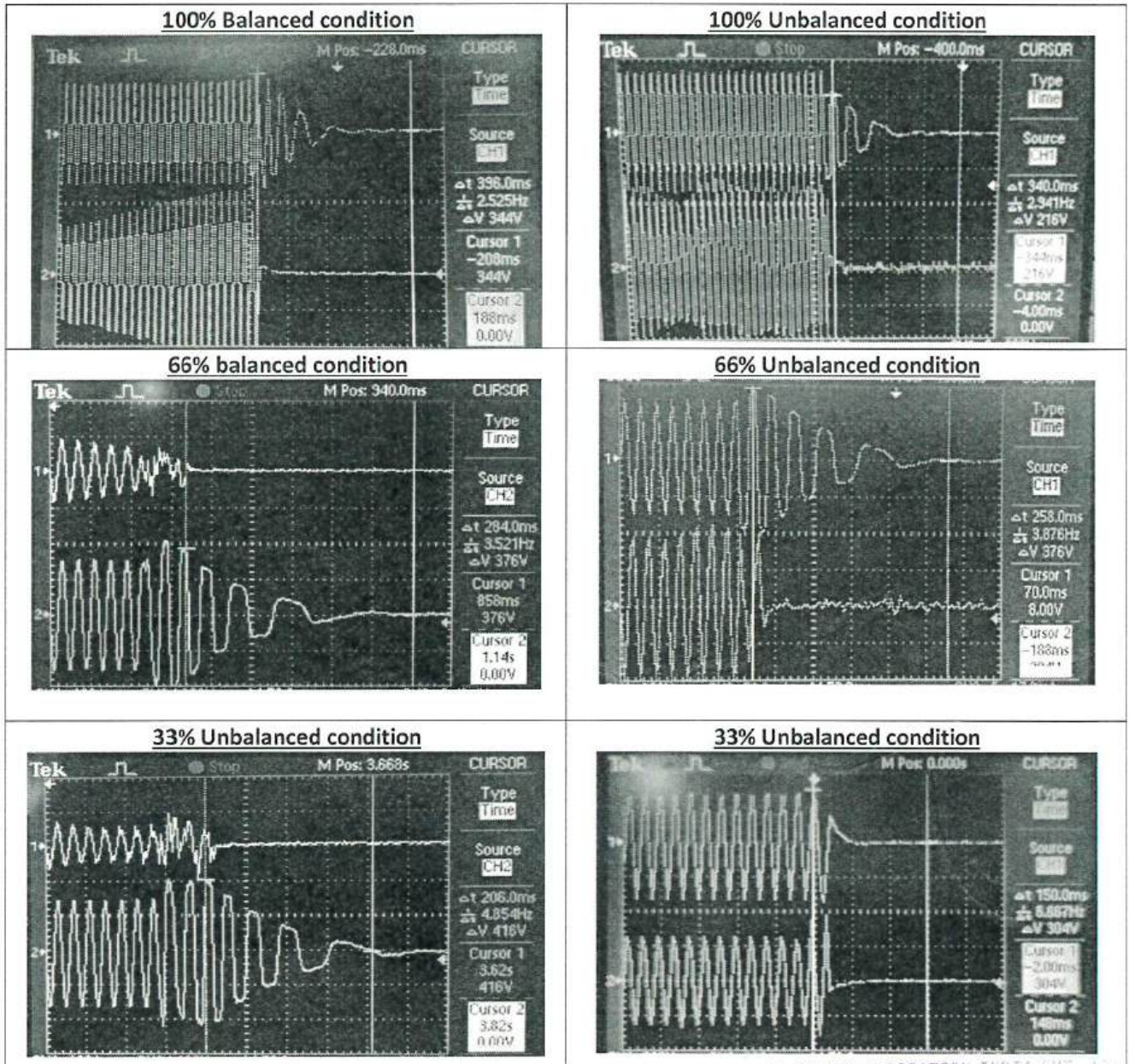

HI PHYSIX LABORATORY INDIA (PVT.) LTD.
[Signature]
Head of the Electronics Division



TC-5100

IS 16169:2014 /IEC 62116:2008			
Clause	Requirement + Test	Result – Remark	Verdict

 TECHNICAL PARAMETER	
MODEL	KSY-22KW-3P
INPUT DC PARAMETER	
Max. peak DC input power (kW)	25
Max. DC input voltage (V)	1000
Max. MPPT input current (A)	26
MPPT short circuit current (A)	40
MPPT Tracking voltage (V)	200-1000
Min start voltage (V)	250
Number of MPPT tracker	2
String per MPPT trackers	2
OUTPUT AC PARAMETER	
Rated output power (kW)	22
Rated grid voltage (V)	400
Nominal grid frequency (Hz)	50
Max. output current AC (A)	31.79
AC connection with PE	3P+N+E
THD (%)	<1
Output power factor (%)	0.8 lead-0.8 lag
EFFICIENCY	
Max. conversion efficiency (%)	98.2
Max. Euro efficiency (%)	97.5
PROTECTION	
Anti-islanding protection	Integrated (as per IEC)
Insulation resistance detection	Integrated
Residual current monitoring	Integrated
Over voltage protection	Supported (as per IEC)
DC switch	Inbuilt
Surge protection	Type III with X+Y capacitor
Other protections	PV lightning, DC input short circuit, DC O/V & U/V, Insulation resistance detection, RCCB, ELCB, Over/under voltage, Over/under frequency, over temperature, AC output PF control, output short circuit protection, Input reserve polarity protection
GENERAL DATA	
Dimensions (W*H*D)	425 x 351 x 200 mm
Weight (kg)	13.7
Noise emission (dB)	<30
Display	LED with LCD display
DC connection Type	MC4
AC connection type	Plug in connector
Communication interface	Wifi/GPRS/RS485/Etherate LAN/ Local monitoring
Cooling method	Natural cooling
Operating ambient	-25-60°C
Relative humidity	0%-100%
Max. operating altitude(m)	2000(+Derating)
Protection class	IP65
Night stand by power consumption (w)	<1
Standard warranty	5.8 Years (Extendable upto 10 year)



HI PHYSIX LABORATORY INDIA PVT. LTD.

(Signature)
Amitade
Electronics Division

IS 16169/ IEC 62116_V1.0



TC-5100

IS 16169:2014 / IEC 62116:2008			
Clause	Requirement + Test	Result – Remark	Verdict

BLOCK DIAGRAM OF TEST CIRCUIT

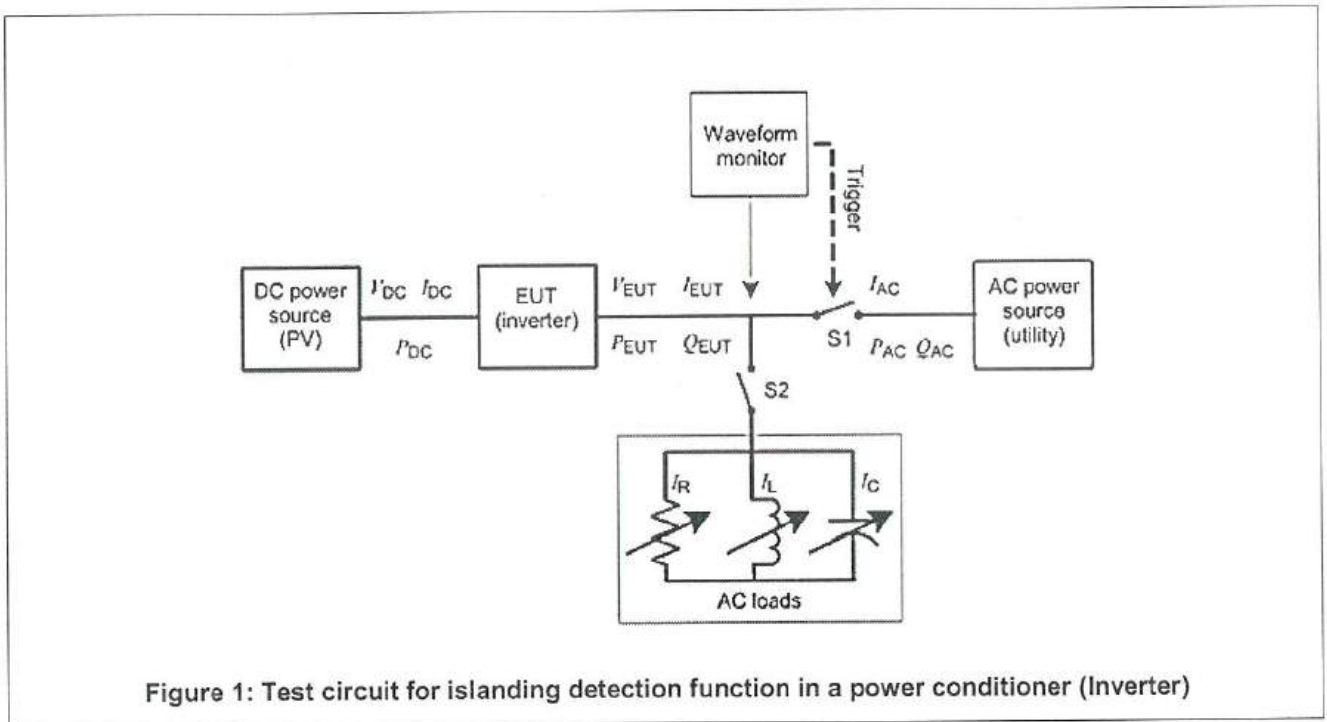

HI PHYSIX LABORATORY INDIA PVT. LTD.
[Signature]
(General Manager, Electronics Division)

-----End of test Report-----



SUMMARY OF TEST REPORT

TEST REPORT NO: HPLI/Test/2204003501

DATE: 16/06/2022

(Number of Pages in Test Report: 107)

TEST FORMAT AS PER IS 16221 (Part 2): 2015/ IEC 62109-2: 2011

1. Name of the Manufacturer: **KSOLARE ENERGY PVT LTD.**
2. Product: Power Invertors for use in photovoltaic power system (Solar Grid Tied inverter)
3. Models: **KSY-22KW-3P (Representative model)**
KSY-20KW-3P, KSY-18KW-3P, KSY-15KW-3P, KSY-12KW-3P, KSY-10KW-3P,
KSY-8KW-3P, KSY-6KW-3P, KSY-5KW-3P, KSY-3KW-3P (**Series models**)
4. Model differences provided (if applicable): **Yes**
5. Model differences verified as per MNRE Guidelines for series formulation: **Yes**
6. Test Results:

SL. NO.	TEST REQUIREMENT	CLAUSE	VERDICT
1.	General testing requirements	4.0	P
2.	Marking and Documentation	5.0	P
3.	Environmental requirements and conditions	6.0	P
4.	Protection against electric shock and energy hazards	7.0	P
5.	Protection against mechanical hazards	8.0	P
6.	Protection against fire hazards	9.0	P
7.	Protection against sonic pressure hazards	10.0	P
8.	Protection against liquid hazards	11.0	N/A
9.	Protection against Chemical Hazards	12.0	N/A
10.	Physical requirements	13.0	P
11.	Components	14.0	P

HI PHYSIX LABORATORY INDIA PVT. LTD.
(General Testing & Electronics Division)



TC-5100

TEST REPORT NO: HPLI/Test/2204003501

DATE: 16/06/2022

General Information:

1. The conformity certificates of critical components are verified to ensure complete testing of apparatus under test and details regarding harmonized IEC standards (where IEC standards are not available) are also provided in the list of critical components.

CONCLUSION:

1. Sample meets all relevant requirements of IS 16221 (Part 2): 2015/ IEC 62109-2: 2011
2. ~~Sample fails to meet the following test requirements:~~

I, hereby undertake that the verdict stated in the test reports for all the test matches with the test results. The sample meets all relevant requirements of IS 16221 (Part 2): 2015/ IEC 62109-2: 2011 ~~does not meet the requirements stated above.~~

HI PHYSIX LABORATORY INDIA PVT. LTD.

Avtarade
(General Manager - Accounts Division)

Date: 16/06/2022

(Signature of Authorized person with Stamp)



TC-5100

TEST REPORT IS 16221 (Part 2):2015 Safety of Power Converter for use in Photovoltaic Power Systems Part 2: Particular requirements for inverters	
Report Number..... :	ULR-TC510022000000496F
Date of issue	HPLI/Test/2204003501
Total number of pages	16/06/2022
Customer name..... :	107
Address..... :	KSOLARE ENERGY PVT LTD. SR NO.62, HISSA NO. 3, MANGADEWADI, KATRAJ, PUNE SATARA ROAD, PUNE, MAHARASTRA-411046
Test specification:	
Standard..... :	IS 16221 (Part 2): 2015
Test procedure..... :	Compliance Report
Non-standard test method..... :	N/A
Test Report Form No. :	TRF No. IS 16221 (Part 2): 2015_V1.0
Test Report Form(s) Originator :	BIS
Master TRF	Dated: 03.10.2018
Test item description..... :	Power Invertors for use in photovoltaic power system (Solar Grid Tied inverter)
Trade Mark..... :	
Manufacturer	KSOLARE ENERGY PVT LTD.
Model/Type reference	KSY-22KW-3P (Representative model) KSY-20KW-3P, KSY-18KW-3P, KSY-15KW-3P, KSY-12KW-3P, KSY-10KW-3P, KSY-8KW-3P, KSY-6KW-3P, KSY-5KW-3P, KSY-3KW-3P(Series models)
Ratings	DC Input: Max. input voltage: 1000Vdc, MPPT voltage range: 200-1000Vdc, Max. input current: 2*26A, Nominal DC input voltage: 620Vdc, Isc: 2*40A. AC Output: Vac: 400V, Fac nominal: 50Hz, Max. output current: 31.79A, Rated ac output power: 22000W, Operating Temp. range: -25 to 60°C (Representative model) (For Series model see copy of marking plate)

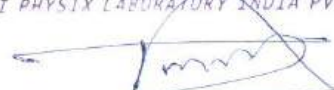
HI PHYSIX LABORATORY INDIA PVT. LTD.

P. S. Sawade
(BUREAU OF INDIAN STANDARDS DIVISION)





TC-5100

Test Report No: HPLI/Test/2204003501

Page 1 of 107

Issue Date: 16/06/2022

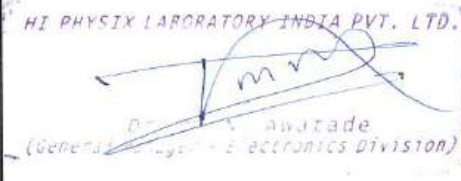
Discipline: Group:	ULR-TC510022000000496F Electronics Testing Miscellaneous Products (Power Conversion Equipment)
Manufacturer:	KSOLARE ENERGY PVT LTD. SR NO.62, HISSA NO. 3, MANGADEWADI, KATRAJ, PUNE SATARA ROAD, PUNE, MAHARASTRA-411046
Test item:	Power Invertors for use in photovoltaic power system (Solar Grid Tied inverter)
Identification:	KSY-22KW-3P (Representative model) Serial No.: KSY0422HT0033, KSY-20KW-3P, KSY-18KW-3P, KSY-12KW-3P, KSY-15KW-3P, KSY-12KW-3P, KSY-10KW-3P, KSY-8KW-3P, KSY-6KW-3P, KSY-5KW-3P, KSY-3KW-3P (Series models)
Receipt No.:	22040035 Date of receipt: 13/04/2022
Testing laboratory and its address:	Hi Physix Laboratory India Pvt. Ltd. B-32/1/2, MIDC, RANJANGAON, PUNE, MAHARASHTRA, PIN-412220.
Test specification:	IS 16221 (Part 2): 2015/ IEC 62109-2: 2011
Test Result:	The test item passed / failed the test specification(s).
Other Aspects:	Nil
This test report relates to the test sample submitted.	

Tested by:	Reviewed & Approved by / Authorized Signatory:	Issued by:
		
(Akshay Salwatkar/ Testing Engineer)	(Dr. M. N. Awatade General Manager- Electronics division)	(K. K. Jayaswal/ Chief Quality Manager)
Date: 16/06/2022	Date: 16/06/2022	Date: 16/06/2022





TC-5100

ULR-TC510022000000496F

Page 3 of 107

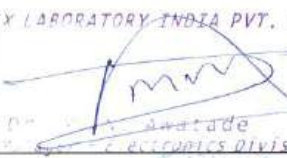
Report No HPLI/Test/2204003501

Testing procedure and testing location:		
<input checked="" type="checkbox"/> Testing Laboratory:	Hi Physix Laboratory India Pvt. Ltd.	
Testing location/ address.....	B-32/1/2, Midc, Ranjangaon, Pune, Maharashtra, Pin-412220.	
<input type="checkbox"/> Testing procedure:		
Tested by (name+ signature).....:	(Akshay Salwatkar/ Testing Engineer)	
Reviewed & Approved by / Authorized Signatory.....:	(Dr. M. N. Awatade General Manager- Electronics division)	 <small>HI PHYSIX LABORATORY INDIA PVT. LTD. (General Manager - Electronics Division)</small>
Issued by (name, function, Signature)	(K. K. Jayaswal/ Chief Quality Manager)	 



TC-5100

ULR-TC510022000000496F

Page 4 of 107

Report No. HPLI/Test/2204003501

List of Attachments (including a total number of pages in each attachment):

Appendix A: User Manual & Installation Manual, pages 23 (page No: 72-94)

Appendix B: List of Critical Component, pages 7 (page No: 95-101)

Appendix C: List of Test and Engineering Rationale, pages 1 (page No: 103)

Appendix D: IS 16221 (Part 2) Test Datasheets, pages 8 (page No: 63-70)

Appendix E: Photos of Equipment, pages 4 (page No: 104-107)

Summary of testing:

Tests performed (name of test and test clause):		Testing location: Hi Physix Laboratory India Pvt. Ltd. B-32/1/2, M.I.D.C., Ranjangaon, Pune, Maharashtra-412220.
Test (s)	Clause (s)	
General testing and requirements	4.0	
Marking and documentation	5.0	
Environmental requirements and conditions	6.0	
Protection against electric shock and energy hazards	7.0	
Protection against mechanical hazards	8.0	
Protection against fire hazards	9.0	
Protection against sonic pressure hazards	10.0	
Physical requirements	13.0	
Components	14.0	

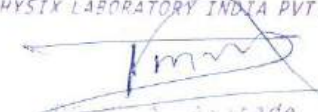
HI PHYSIX LABORATORY INDIA PVT. LTD.

Anantade
(General Manager - Electronics Division)

TRF No. IS 16221 (Part 2) : 2015_V1.0



TC-5100

Copy of marking plate of the equipment (Representative model)



5G-PRO
KSY-22KW-3P Solar GTI

Max. input voltage	1000Vdc
MPPT voltage range	200-1000V
Max. input current	2*26A
Nominal DC input voltage	620V
Isc PV	2*40A
Vac/Fac Normal	400Vac/50Hz
Max. output current	31.78A
Rated AC output power	22000W
MFG Date	18/02/22
Power Factor	>0.99
Operating Temp. range	-25- +60 degree C
Deg. of protection	IP 65



SN: KSY0422HT0033

IEC61683,61727,60068,61727,61000,62109



KSOLARE ENERGY PVT. LTD
SP. NO 52, HISSA NO 3, MANGADEWADI,
KATRAJ, PUNE SATARA ROAD, PUNE - 411046, INDIA
www.ksolare.com



5G-PRO
KSY-22KW-3P Solar GTI

Max. input voltage	1000Vdc
MPPT voltage range	200-1000V
Max. input current	2*26A
Nominal DC input voltage	620V
Isc PV	2*40A
Vac/Fac Normal	400Vac/50Hz
Max. output current	31.78A
Rated AC output power	22000W
MFG Date	18/02/22
Power Factor	>0.99
Operating Temp. range	-25- +60 degree C
Deg. of protection	IP 65



SN: KSY0422HT0034

IEC61683,61727,60068,61727,61000,62109

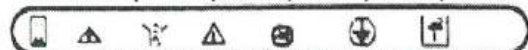

KSOLARE ENERGY PVT. LTD
SP. NO 52, HISSA NO 3, MANGADEWADI,
KATRAJ, PUNE SATARA ROAD, PUNE - 411046, INDIA
www.ksolare.com

HI PHYSIX LABORATORY INDIA PVT. LTD.
(Signature)
Awade
(General Manager - Electronics Division)



TC-5100

Copy of marking plate of series models



5G-PRO
KSY-20KW-3P Solar GTI

Max. input voltage	1000Vdc
MPPT voltage range	200-1000V
Max. input current	2*25A
Nominal DC input voltage	620V
Isc PV	2*40A
Vac/Fac Normal	400Vac/50Hz
Max. output current	28.8A
Rated AC output power	20000W
MFG Date	18/02/22
Power Factor	>0.99
Operating Temp. range	-25~ +60 degree C
Deg. of protection	IP 65



SN: KSY0422HS0048

IEC61683,61727,60068,61727,61000,62109



KSOLARE ENERGY PVT. LTD.
SR NO 52, HISSA NO 3, MANGADEVADI,
KATRAJ, PUNE SATARA ROAD, PUNE - 411045, INDIA
www.ksolare.com



5G-PRO
KSY-18KW-3P Solar GTI

Max. input voltage	1000Vdc
MPPT voltage range	200-1000V
Max. input current	2*25A
Nominal DC input voltage	620V
Isc PV	2*40A
Vac/Fac Normal	400Vac/50Hz
Max. output current	26.01A
Rated AC output power	18000W
MFG Date	18/02/22
Power Factor	>0.99
Operating Temp. range	-25~ +60 degree C
Deg. of protection	IP 65



SN: KSY0422HS0047

IEC61683,61727,60068,61727,61000,62109

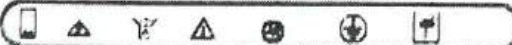

KSOLARE ENERGY PVT. LTD.
SR NO 52, HISSA NO 3, MANGADEVADI,
KATRAJ, PUNE SATARA ROAD, PUNE - 411045, INDIA
www.ksolare.com

HI PHYSIX LABORATORY INDIA PVT. LTD.
(Signature)
Awatade
(General Manager - Electronics Division)



TC-5100

Copy of marking plate of series models



5G-PRO

KSY-15KW-3P Solar GTI

Max. input voltage	1000Vdc
MPPT voltage range	200-1000V
Max. input current	2*25A
Nominal DC input voltage	620V
Isc PV	2*40A
Vac/Fac Normal	400Vac/50Hz
Max. output current	21.67A
Rated AC output power	15000W
MFG Date	18/02/22
Power Factor	>0.99
Operating Temp. range	-25~ +60 degree C
Deg. of protection	IP 65



SN: KSY0422HS0045

IEC61683,61727,60068,61727,61000,62109



KSOLARE ENERGY PVT. LTD.
SR NO 52, HISSA NO 3, MANGADEWADI,
KATRAJ, PUNE SATARA ROAD, PUNE - 411045, INDIA
www.ksolare.com



5G-PRO

KSY-12KW-3P Solar GTI

Max. input voltage	1000Vdc
MPPT voltage range	200-1000V
Max. input current	2*13A
Nominal DC input voltage	620V
Isc PV	2*15A
Vac/Fac Normal	400Vac/50Hz
Max. output current	17.34A
Rated AC output power	12000W
MFG Date	18/02/22
Power Factor	>0.99
Operating Temp. range	-25~ +60 degree C
Deg. of protection	IP 65



SN: KSY0422HS0044

IEC61683,61727,60068,61727,61000,62109



KSOLARE ENERGY PVT. LTD.
SR NO 52, HISSA NO 3, MANGADEWADI,
KATRAJ, PUNE SATARA ROAD, PUNE - 411045, INDIA
www.ksolare.com

HI PHYSIX LABORATORY INDIA PVT. LTD.
(Signature)
Awatade
(General Manager - Electronics Division)



TC-5100

Copy of marking plate of series models



5G-PRO
KSY-10KW-3P Solar GTI

Max. input voltage	1000Vdc
MPPT voltage range	200-1000V
Max. input current	2*13A
Nominal DC input voltage	620V
Isc PV	2*15A
Vac/Fac Normal	400Vac/50Hz
Max. output current	14.5A
Rated AC output power	10000W
MFG Date	18/02/22
Power Factor	>0.99
Operating Temp. range	-25- +60 degree C
Deg. of protection	IP 65



SN: KSY0422HS0043

IEC61683,61727,60068,61727,61000,62109

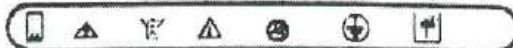

KSOLARE ENERGY PVT LTD
SP NO 52, HISSA NO 3, MANGADEWADI,
KATRAJ, PUNE SATARA ROAD, PUNE - 411046, INDIA
www.ksolare.com



5G-PRO
KSY-8KW-3P Solar GTI

Max. input voltage	1000Vdc
MPPT voltage range	200-1000V
Max. input current	2*13A
Nominal DC input voltage	620V
Isc PV	2*15A
Vac/Fac Normal	400Vac/50Hz
Max. output current	11.56A
Rated AC output power	8000W
MFG Date	18/02/22
Power Factor	>0.99
Operating Temp. range	-25- +60 degree C
Deg. of protection	IP 65



SN: KSY0422HS0040

IEC61683,61727,60068,61727,61000,62109



KSOLARE ENERGY PVT LTD
SP NO 52, HISSA NO 3, MANGADEWADI,
KATRAJ, PUNE SATARA ROAD, PUNE - 411046, INDIA
www.ksolare.com

HI PHYSIX LABORATORY INDIA PVT. LTD.
[Signature]
S. S. Sawade
(General Manager - Electronics Division)



TC-5100

Copy of marking plate of series models



KSY-6KW-3P Solar GTI

Max. input voltage	1000Vdc
MPPT voltage range	200-1000V
Max. input current	2*13A
Nominal DC input voltage	620V
Isc PV	2*15A
Vac/Fac Normal	400Vac/50Hz
Max. output current	8.67A
Rated AC output power	6000W
MFG Date	18/02/22
Power Factor	>0.99
Operating Temp. range	-25- +60 degree C
Deg. of protection	IP 65



SN: KSY0422HS0038

IEC61683,61727,60068,61727,61000,62109



KSOLARE ENERGY PVT. LTD.
SR NO 52, HISSA NO 3, MANGADEWADI,
KATRAJ, PUNE SATARA ROAD, PUNE - 411046, INDIA
www.ksolare.com



KSY-5KW-3P Solar GTI

Max. input voltage	1000Vdc
MPPT voltage range	200-1000V
Max. input current	2*13A
Nominal DC input voltage	620V
Isc PV	2*15A
Vac/Fac Normal	400Vac/50Hz
Max. output current	7.22A
Rated AC output power	5000W
MFG Date	18/02/22
Power Factor	>0.99
Operating Temp. range	-25- +60 degree C
Deg. of protection	IP 65



SN: KSY0422HS0037

IEC61683,61727,60068,61727,61000,62109



KSOLARE ENERGY PVT. LTD.
SR NO 52, HISSA NO 3, MANGADEWADI,
KATRAJ, PUNE SATARA ROAD, PUNE - 411046, INDIA
www.ksolare.com



TC-5100

Copy of marking plate of series model



5G-PRO

KSY-3KW-3P Solar GTI

Max. input voltage	1000Vdc
MPPT voltage range	200-1000V
Max. input current	2*13A
Nominal DC input voltage	620V
Isc PV	2*15A
Vac/Fac Normal	400Vac/50Hz
Max. output current	4.3A
Rated AC output power	3000W
MFG Date	18/02/22
Power Factor	>0.99
Operating Temp. range	-25- +60 degree C
Deg. of protection	IP 65



SN: KSY0422HS0035

IEC61683,61727,60068,61727,61000,62109

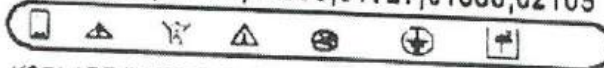

KSOLARE ENERGY PVT LTD.
SR NO 52, HISSA NO 3, MANGADEWADI,
KATRAJ, PUNE SATARA ROAD, PUNE - 411045, INDIA
www.ksolare.com

HI PHYSIX LABORATORY INDIA PVT. LTD.
(Signature)
Electronics Division



TC-5100

Test item particulars.....: Power Invertors for use in photovoltaic power system (Solar Grid Tied inverter)

Equipment mobility.....: movable hand-held stationary
fixed transportable for building-in

Connection to the mains.....: pluggable equipment direct plug-in
permanent connection for building-in

Environmental category.....: Outdoor indoor unconditional
indoor conditioned

Over voltage category Mains.....: OVCI OVCI OVCI OVCIV

Over voltage category PV: OVCI OVCI OVCI OVCIV

Mains supply tolerance (%): -90 / +110 %

Tested for power systems: Yes (TN)

IT testing, phase-phase voltage (V): ---

Class of equipment: Class I Class II Class III
Not classified

Mass of equipment (kg): 20.06kg

Pollution degree: PD1 PD2 PD3

IP protection class.....: IP65

Possible test case verdicts:

-test case does not apply to the test object.....: N/A

- test object does meet the requirement: P (Pass)

-test object was note valuated for the requirement N/E

- test object does not meet the requirement.....: F (Fail)

Testing.....:

Date of receipt of test item.....: 13/04/2022

Date (s) of performance of tests.....: 20/04/2022-14/06/2022

General remarks:

The test results presented in this report relate only to the object tested.
This report shall not be reproduced, except in full, without the written approval of the issuing testing laboratory.
The Management System is maintained in accordance with IS/ISO/IEC 17025:2017 and testing Standards/Instruments are traceable to National / International Standards
"(see Enclosure #)" refers to additional information appended to the report. "(see appended table)" refers to a table appended to the report.
Throughout this report a comma / point is used as the decimal separator.





TC-5100

Manufacturer's Declaration per Standard:

Similarities between the models: Representative models and series models have following similarities

- 1) Same rated Input/ Output voltage: 620VDC/400VAC
- 2) Same frequency: 50Hz
- 3) Number of Phases at output: Three phase
- 4) Same PCB design and layout: Same
- 5) Same Power Stage topology: Non-isolated
- 6) Same Insulation Class: Transformer less
- 7) Same Control Algorithm/firmware: V1.0, Firmware Version Name: Ver 1.0, Hardware Version Name: KSY
- 8) Same Cabinet Design: IP65
- 9) Class of construction: Class I

Differences between the models: Representative models and series models have following differences: Model description, Electrical rating (as mentioned in marking plate), Dimensions & weight.

General product information:

The product covered under this test report is power converters for use in photovoltaic power systems. The details of the product are stated below:

Manufacturer: KSOLARE ENERGY PVT LTD.

Input rating: Max. input voltage: 1000Vdc, MPPT voltage range: 200-1000Vdc, Max. input current: 2*26A, Nominal DC input voltage: 620Vdc, Isc: 2*40A.

Output rating: Vac: 400V, Fac nominal: 50Hz, Max. output current: 72.25A, Rated ac output power: 22000W, Operating Temp. range: -25 to 60°C

Class of equipment: Class I

Overvoltage category: OVC II (PV). OCV III(Mains)

Pollution degree: PD III

Connection to the mains: Permanent connection

Ambient temperature range: -25° to +60°C

IP protection class: IP65

Dimensions: 425 x 351 x 200 mm

Sample code by online request is "SC22SPI00247"



TC-5100

IS 16221 (PART 2):2015

Clause	Requirement + Test	Result - Remark	Verdict
4	General testing requirements	See below	P
4.1 /RD	General	Test carried out under reference test conditions and under both normal & single fault conditions.	P
4.2/RD	General conditions for testing	See below	P
4.2.1/RD	Sequence of tests	Considered as per MNRE guidelines	P
4.2.2/RD	Reference test conditions	See below	P
4.2.2.1/RD	Environmental conditions	Temperature:15 to 40°C Relative humidity: not more than 75% Air pressure: 75kPa to 106kPa No frost, dew, percolating water, rain, solar radiation	P
4.2.2..2/RD	State of equipment	All tests have been carried out on model which represent the future production unit with complete assemblies	P
4.2.2.3/RD	Position of equipment	The equipment were installed in accordance with the manufacturer's instructions	P
4.2.2.4/RD	Accessories	No accessories or operator interchangeable parts used.	N/A
4.2.2.5/RD	Covers and removable parts	No covers and removable parts	N/A
4.2.2.6/RD	Mains supply a) Voltage: b) Frequency: c) Polarity: d) Earthing: e) Over-current Protection:	a)400Vac b) 50Hz c) Not pluggable equipment type A d) Earthed supply system used e) Part of equipment	P
4.2.2.7/RD	Supply ports other than the mains	See below	P
4.2.2.7.1/RD	Photovoltaic supply sources a) Open circuit voltage: b) Short-circuit current:	PV array simulator used with suitable compatibility	P
4.2.2.7.2/RD	Battery inputs	No battery used	N/A
4.2.2.8/RD	Conditions of loading for output ports	DC to AC inverter. A.C. output port was loaded with linear loads to obtain the maximum rated output power. Continuous operation ratings, until steady conditions are established.	P
4.2.2.9 /RD	Earthing terminals	Protective conductor terminal was connected to earth. No functional earth terminal.	P
4.2.2.10/RD	Controls	No mains selection devices and No combinations of settings devices	N/A
4.2.2.11/RD	Available short circuit current	Considered	P
4.3/RD	Thermal testing	See appended table 4.3	P
4.3.1/RD	General	See appended table 4.3	P
4.3.2/RD	Maximum temperatures	Tests of equipment rated for use in ambient temperatures up to 60°C	P
4.3.2.1/RD	General	See appended table 4.3	P

TRF No. IS 16221 (Part 2): 2015_V1.0

HI PHYSIX LABORATORY INDIA PVT. LTD.
(Signature)
S. Awatade
(General Manager - Electronics Division)



TC-5100

IS 16221 (PART 2):2015			
Clause	Requirement + Test	Result - Remark	Verdict
4.3.2.2/RD	Touch temperatures	See appended table 4.3	P
4.3.2.3/RD	Temperatures limits for mounting surfaces	See appended table 4.3	P
4.4/RD	Testing in single fault condition	See appended table 4.4	P
4.4.1/RD	General	See appended table 4.4	P
4.4.2/RD	Test conditions and duration for testing under fault conditions	See below	P
4.4.2.1/RD	General	Considered	P
4.4.2.2/RD	Duration of tests	Considered	P
4.4.3/RD	Pass/fail criteria for testing under fault conditions	See below	P
4.4.3.1/RD	Protection against shock hazard	No shock hazards	P
4.4.3.2/RD	Protection against the spread of fire	No spread of fire	P
4.4.3.3/RD	Protection against other hazards	No other hazards	P
4.4.3.4/RD	Protection against parts expulsion hazards	No expulsion hazards	P
4.4.4	Single fault conditions to be applied	See below	P
4.4.4.1/RD	Component fault tests	See appended table 4.4	P
4.4.4.2 /RD	Equipment or parts for short-term or intermittent operation	For continuous operation	N/A
4.4.4.3 /RD	Motors	See appended table 4.4	P
4.4.4.4/RD	Transformer short circuit tests	See appended table 4.4	P
4.4.4.5/RD	Output short circuit	See appended table 4.4	P
4.4.4.6/RD	Backfeed current test for equipment with more than one source of supply	Only single source of supply used	N/A
4.4.4.7/RD	Output overload	See appended table 4.4	P
4.4.4.8/RD	Cooling system failure	See appended table 4.4	P
4.4.4.9/RD	Heating devices	No heating devices used	N/A
4.4.4.10/RD	Safety interlock systems	No such system used	N/A
4.4.4.11/RD	Reverse d.c. connections	Instructions provide in installation manual	P
4.4.4.12/RD	Voltage selector mismatch	No voltage selector	N/A
4.4.4.13/RD	Mis-wiring with incorrect phase sequence or polarity	No hazards observed	P
4.4.4.14/RD	Printed wiring board short-circuit test	See appended table 4.4	P
4.4.4.15	Fault-tolerance of protection for grid-interactive inverters	See below	P
4.4.4.15.1	Fault-tolerance of residual current monitoring according to 4.8.3.5: the residual current monitoring system operates properly	See appended table 4.4.4.15.1	P
	a)-The inverter ceases to operate	See above clause 4.4.4.15.1	P
	-Indicates a fault in accordance with 13.9	See above clause 4.4.4.15.1	P
	-Disconnect from the mains	See above clause 4.4.4.15.1	P

TRF No. IS 16221 (Part 2): 2015_V1.0

HI PHYSIX LABORATORY INDIA PVT. LTD.
(Signature)
Awatade
(General Manager - Electronics Division)



TC-5100

IS 16221 (PART 2):2015			
Clause	Requirement + Test	Result - Remark	Verdict
	-not re-connect after any sequence of removing and reconnecting PV power	See above clause 4.4.4.15.1	P
	-not re-connect after any sequence of removing and reconnecting AC power	See above clause 4.4.4.15.1	P
	-not re-connect after any sequence of removing and reconnecting both PV and AC power	See above clause 4.4.4.15.1	P
	b) The inverter continues to operate	Inverter ceases to operate	N/A
	the residual current monitoring system operates properly under single fault condition	See above clause 4.4.4.15.1	N/A
	c) The inverter continues to operate regardless of loss of residual current monitoring functionality	Inverter ceases to operate	N/A
	-not re-connect after any sequence of removing and reconnecting PV power	See above clause 4.4.4.15.1	N/A
	-not re-connect after any sequence of removing and reconnecting AC power	See above clause 4.4.4.15.1	N/A
	-not re-connect after any sequence of removing and reconnecting both PV and AC power	See above clause 4.4.4.15.1	N/A
	-Indicates a fault in accordance with 13.9	See above clause 4.4.4.15.1	N/A
4.4.4.15.2	Fault-tolerance of automatic disconnecting means	Considered	P
4.4.4.15.2.1	The means provided for automatic disconnection of a grid-interactive inverter from the mains shall:	See below	P
	-disconnect all grounded current-carrying conductors from the mains	Disconnected all grounded current carrying conductors from the mains	P
	-disconnect all ungrounded current-carrying conductors from the mains	Disconnected all ungrounded current carrying conductors from the mains	P
	-be such that with a single fault applied to the disconnection means or to any other location in the inverter, at least basic insulation or simple separation is maintained between the PV array and the mains when the disconnecting means is intended to be in the open state.	Basic insulation is maintained between PV array and mains	P
4.4.4.15.2.2	Design of insulation or separation complies with requirements of 7.3.7 of Part 1: report here Part1 comment and verdict.	Complies	P

TRF No. IS 16221 (Part 2): 2015_V1.0

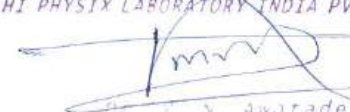
HI PHYSIX LABORATORY INDIA PVT. LTD.

 Y. Awitade
 (General Manager - ELECTRONICS DIVISION)



TC-5100

IS 16221 (PART 2):2015			
Clause	Requirement + Test	Result - Remark	Verdict
4.4.4.15.2.3	For non-isolated inverter, automatic checking of the isolation provided by a disconnect means after single fault.	The inverter automatic checking of the isolation after single fault occurred	P
	If the check fail: -any still functions disconnection means shall be left in the open position	Complies	P
	-at least basic or simple separation shall be maintained between the PV input and the mains	Basic insulation is maintained between PV array and mains	P
	-the inverter shall not start operation	Complies	P
	-the inverter shall indicate a fault in accordance with 13.9	The screen shows error information	P
4.4.4.16	A stand-alone inverter with a transfer switch to transfer AC loads from the mains or other AC bypass source to the inverter output:	Nota stand-alone inverter	N/A
	-shall continue to operatenormally	See above clause no. 4.4.4.16	N/A
	-shallnotpresentariskoffireastheresultofan out-of-phasetransfer	See above clause no. 4.4.4.16	N/A
	- shallnotpresentariskofshockastheresultofan out-of-phase transfer	See above clause no. 4.4.4.16	N/A
	Foraninverteremployingabypassswitchhavinga control preventing switching, the test is to be conducted under the condition of acomponent malfunction	See above clause no. 4.4.4.16	N/A
4.4.4.17	Cooling system failure – Blanketing test No hazards according to the criteria of sub-clause 4.4.3 of Part 1 shall result from blanketing the inverter This test is not required for inverters restricted to useonly in closed electrical operating areas.	See appended table 4.4.4.17	P
	Test stop condition: time duration value or stabilized temperature	See appended table 4.4.4.17	P
4.5/RD	Humidity preconditioning	See below	P
4.5.1/RD	General	Considered	P
4.5.2/RD	Conditions	Humidity: 92.5±2.5%RH Temperature: 40±2°C Duration: 48h	P
4.6/RD	Backfeed voltage protection	See below	P
4.6.1/RD	Backfeed tests under normal conditions	Input side: Positive to negative 3.0mV	P
4.6.2/RD	Backfeed tests under single-fault conditions	Input side: Positive to negative7.0mV	P
4.6.3/RD	Compliance with backfeed tests	No hazards present after 15s	P
4.7	Electrical ratings tests	See below	P
4.7.1/RD	Input ratings	See appended table 4.7	P
4.7.1.1/RD	Measurement requirements for DC input ports	See appended table 4.7	P
4.7.2/ RD	Output ratings	See appended table 4.7	P

TRF No. IS 16221 (Part 2): 2015_V1.0

HI PHYSIX LABORATORY INDIA PVT. LTD.
(Signature)
Awatade



TC-5100

IS 16221 (PART 2):2015			
Clause	Requirement + Test	Result - Remark	Verdict
4.7.3	Measurement requirements for AC output ports for standalone inverters	Not a standalone inverter	N/A
4.7.4	Stand-alone Inverter AC output voltage and frequency	Not a standalone inverter	N/A
4.7.4.1	General	See above clause no. 4.7.4	N/A
4.7.4.2	Steady state output voltage at nominal DC input The steady-state AC output voltage shall not be less than 90 % or more than 110 % of the rated nominal voltage with the inverter supplied with its nominal value of DC input voltage.	See above clause no. 4.7.4	N/A
4.7.4.3	Steady state output voltage across the DC input range The steady-state AC output voltage shall not be less than 85 % or more than 110 % of the rated nominal voltage with the inverter supplied with any value within the rated range of DC input voltage.	See above clause no. 4.7.4	N/A
4.7.4.4	Load step response of the output voltage at nominal DC input The AC output voltage shall not be less than 85 % or more than 110 % of the rated nominal voltage for more than 1.5 s after application or removal of a resistive load.	See above clause no. 4.7.4	N/A
4.7.4.5	Steady state output frequency The steady-state AC output frequency shall not vary from the nominal value by more than +4 % or -6 %.	See above clause no. 4.7.4	N/A
4.7.5	Stand-alone inverter output voltage waveform	Not a standalone inverter	N/A
4.7.5.1	General	See above clause no. 4.7.5	N/A
4.7.5.2	The AC output voltage waveform of a sinusoidal output stand-alone inverter shall have a total harmonic distortion (THD) not exceeding of 10 % and no individual harmonic at a level exceeding 6%.	See above clause no. 4.7.5	N/A
4.7.5.3	Non-sinusoidal output waveform requirements	Not a standalone inverter	N/A
4.7.5.3.1	General	See above clause no. 4.7.5.3	N/A
4.7.5.3.2	The total harmonic distortion (THD) of the voltage waveform shall not exceed 40 %.	See above clause no. 4.7.5.3	N/A
4.7.5.3.3	The slope of the rising and falling edges of the positive and negative half-cycles of the voltage waveform shall not exceed 10 V/ μ s measured between the points at which the waveform has a voltage of 10% and 90% of the peak voltage for that half-cycle.	See above clause no. 4.7.5.3	N/A
4.7.5.3.4	The absolute value of the peak voltage of the positive and negative half-cycles of the waveform shall not exceed 1.414 times 110% of the RMS value of the rated nominal AC output voltage.	See above clause no. 4.7.5.3	N/A
4.7.5.4	Information requirements for non-sinusoidal waveforms The instructions provided with a stand-alone inverter not complying with 4.7.5.2 shall include the information in 5.3.2.6.	See above clause no. 4.7.5.3	N/A

TRF No. IS 16221 (Part 2): 2015_V1.0

HI PHYSIX LABORATORY INDIA PVT. LTD.

 Anantade
 (Responsible Division)



TC-5100

IS 16221 (PART 2):2015			
Clause	Requirement + Test	Result - Remark	Verdict
4.7.5.5	Output voltage waveform requirements for inverters For dedicated loads. For an inverter that is intended only for use with a known dedicated load, the Following requirements may be used as an alternative to the waveform requirements in 4.7.5.2 to 4.7.5.3.	See above clause no. 4.7.5.3	N/A
	The combination of the inverter and dedicated load shall be evaluated to ensure that the output waveform does not cause any hazards in the load equipment and inverter, or cause the load equipment to fail to comply with the applicable product safety standards.	See above clause no. 4.7.5.3	N/A
	The inverter shall be marked with symbols 9 and 15 of Table C.1 of Part 1.	See above clause no. 4.7.5.3	N/A
	The installation instructions provided with the inverter Shall include the information in 5.2.3.13	See above clause no. 4.7.5.3	N/A
4.8	Additional tests for grid-interactive inverters	See below	P
4.8.1	General requirements regarding inverter isolation and array grounding	Non-isolated inverter	N/A
	- Type of Array grounding supported.....:	The EUT is intended to be used with ungrounded array	N/A
	- Inverter isolation.....:	Non-isolation inverter	N/A
4.8.2	Array insulation resistance detection for inverters for ungrounded and functionally grounded arrays	See below	P
4.8.2.1	Array insulation resistance detection for inverters for ungrounded arrays	See appended table 4.8.2	P
	Inverter shall have means to measure DC insulation resistance from PV input (array) to ground before starting operation	Complies	P
	Or Inverter shall be provided with instruction in accordance with 5.3.2.11.	The inverter can measure DC insulation resistance from PV input array to ground before starting operation	N/A
	Measured DC insulation resistance:	See appended table 4.8.2	P
	Inverter measurement circuit shall be capable of detecting insulation resistance below the limit value $R = V_{max}/30mA$ under normal conditions	Complies	P
	Inverter measurement circuit shall be capable of detecting insulation resistance below the limit value $R = V_{max}/30mA$ with ground fault in the PV array	Complies	P
	Isolated inverters shall indicate a fault if the insulation resistance is less than the limit value	The EUT is non-isolated inverter	N/A
	Isolated inverter fault indication maintained until insulation resistance has recovered to a value higher than the limit value	The EUT is non-isolated inverter	N/A
	Non-isolated inverters, or inverters with isolation not complying with the leakage current limits in the minimum inverter isolation requirements in Table 30:	See below	P
	- shall indicate a fault in accordance with 13.9	The screen shows fault information	P

TRF No. IS 16221 (Part 2): 2015_V1.0

HI PHYSIX LABORATORY INDIA PVT. LTD.
[Signature]



TC-5100

IS 16221 (PART 2):2015			
Clause	Requirement + Test	Result - Remark	Verdict
	- shall not connect to the mains	Not connect to the mains	P
4.8.2.2	Array insulation resistance detection for inverters for functionally grounded arrays	Not a functionally grounded array	N/A
	a-1) The value of the total resistance, including the intentional resistance for array functional grounding, the expected insulation resistance of the array to ground, and the resistance of any other networks connected to ground (for example measurement networks) must not be lower than $R = (V_{MAX} PV/30 \text{ mA})$ ohms.	See above clause no. 4.8.2.2	N/A
	a-2) The installation instructions shall include the Information required in 5.3.2.12.	See above clause no. 4.8.2.2	N/A
	b-1) As an alternative to a), or if a resistor value lower than in a) is used, the inverter shall incorporate means to detect, during operation, if the total current through the resistor and any networks (for example measurement networks) in parallel with it, exceeds the residual current values and times in Table 31	See above clause no. 4.8.2.2	N/A
	b-2) Inverter shall either disconnect the resistor or limit the current by other means	See above clause no. 4.8.2.2	N/A
	b-3) If the inverter is a non-isolated inverter, or has isolation not complying with the leakage current limits in the minimum inverter isolation requirements in Table 30, it shall also disconnect from the mains.	See above clause no. 4.8.2.2	N/A
	c) The inverter shall have means to measure the DC insulation resistance from the PV input to ground before starting operation, in accordance with 4.8.2.1.	See above clause no. 4.8.2.2	N/A
4.8.3	Array residual current detection	See below	P
4.8.3.1	General	Complies	P
4.8.3.2	30 mA touch current type test for isolated inverters	The EUT is non-isolated inverter	N/A
4.8.3.3	Fire hazard residual current type test for isolated inverters	The EUT is non-isolated inverter	N/A
4.8.3.4	Protection by application of RCD's	The EUT provides an integral RCD	N/A
	-The requirement for additional protection in 4.8.3.1 can be met by provision of an RCD with a residual current setting of 30 mA, located between the inverter and the mains.	See above clause no. 4.8.3.4	N/A
	-The selection of the RCD type to ensure compatibility with the inverter must be made According to rules for RCD selection in Part 1.	See above clause no. 4.8.3.4	N/A
	-The RCD provided integral to the inverter, or	See above clause no. 4.8.3.4	N/A
	-The RCD provided by the installer if details of the rating, type, and location for the RCD are given in the installation instructions per 5.3.2.9.	See above clause no. 4.8.3.4	N/A
4.8.3.5	Protection by residual current monitoring	See below	P

TRF No. IS 16221 (Part 2): 2015_V1.0

HI PHYSIX LABORATORY INDIA PVT. LTD.

 D. S. Awatade
 (Electronics Division)



TC-5100

IS 16221 (PART 2):2015			
Clause	Requirement + Test	Result – Remark	Verdict
4.8.3.5.1	General	The EUT provides an integral RCD	P
	Where required by Table 30, the inverter shall provide residual current monitoring that functions whenever the inverter is connected to the mains with the automatic disconnection means closed.	The residual current measured before EUT start up	P
	The residual current monitoring means shall measure the total (both a.c. and d.c. components) RMS current.	Complies	P
	As indicated in Table 30 for different inverter types, array types, and inverter isolation levels, detection may be required for excessive continuous residual current, excessive sudden changes in residual current, or both, according to the following limits:	Considered	P
	a) Continuous residual current: The inverter shall disconnect within 0.3 s and indicate a fault in accordance with 13.9 if the continuous residual current exceeds:	See appended table 4.8.3.5	P
	-maximum 300 mA for inverters with continuous output power rating ≤ 30 kVA;	Complies	P
	-maximum 10 mA per kVA of rated continuous output power for inverters with continuous output power rating > 30 kVA.	See above	N/A
	The inverter may attempt to re-connect if the array insulation resistance meets the limit in 4.8.2.	Complies	P
	b) Sudden changes in residual current: The inverter shall disconnect from the mains within the time specified in Table 31	See appended table 4.8.3.5	P
	The inverter indicates a fault in accordance with 13.9, if a sudden increase in the RMS residual current is detected exceeding the value in the table.	See appended table 4.8.3.5	P
	The inverter may attempt to re-connect if the array insulation resistance meets the limit in 4.8.2.	Complies	P
4.8.3.5.2	Test for detection of excessive continuous residual current: test repeated 5 times and time to disconnect shall not exceed 0.3 s.	See appended table 4.8.3.5.2	P
4.8.3.5.3	Test for detection of sudden changes in residual current repeated 5 times and each of the 5 results shall not exceed the time limit indicated in for each row (30mA, 60mA and 150mA) of Table 31.	See appended table 4.8.3.5.3	P
4.8.3.6	Systems located in closed electrical operating areas	Not located in the closed electrical operating area	N/A
	The protection against shock hazard is not required if the installation information provided with the inverter indicates the restriction for use in a closed electrical operating area, and	See above clause no. 4.8.3.6	N/A



TC-5100

IS 16221 (PART 2):2015			
Clause	Requirement + Test	Result - Remark	Verdict
	Installation information indicates what forms of shock hazard protection are and are not provided integral to the inverter, in accordance with 5.3.2.7.	See above clause no. 4.8.3.6	N/A
	The inverter shall be marked as in 5.2.2.6.	See above clause no. 4.8.3.6	N/A
5	MARKING AND DOCUMENTATION	See below	P
5.1	Marking	See below	P
5.1.1/RD	General	See below	P
	Equipment shall bear markings as specified in 5.1 and 5.2	The marking plate is on the outer surface of enclosure	P
	Graphic symbols may be used and shall be in accordance with Annex C or IEC 60417 as applicable	All used graphical symbols are in accordance with annex C	P
	Graphic symbols shall be explained in the documentation provided with the PCE	The explanations are provided in the manual	P
5.1.2/RD	Durability of markings	See below	P
	Markings required by this clause to be located on the PCE shall remain clear and legible under conditions of NORMAL USE and resist the effects of cleaning agents specified by the manufacturer	The label was subjected to the permanence of marking test. The label was rubbed with cloth soaked with water for 30 sec. and then again for 30 sec. with the cloth soaked with petroleum spirit. After the test, the markings are clearly legible There was neither loose nor curling on the edge of the label.	P
5.1.3/RD	Identification	See below	P
	The equipment shall, as a minimum, be permanently marked with:	See below	P
	a) the name or trade mark of the manufacturer or supplier	Trade mark: "K Solare" marked on the label	P
	b) model number, name or other means to identify the equipment	Model no.:KSY-22KW-3P marked on the label	P
	c) a serial number, code or other marking allowing identification of manufacturing location and the manufacturing batch or date within a three-month time period.	Serial no. KSY0422HT0033, KSY0422HT0034 marked on the label	P
5.1.4	Equipment ratings	See below	P
	PV input ratings:	See below	P
	- Vmax PV (absolute maximum) (d.c. V)	1000Vdc	P
	- Isc PV (absolute maximum) (d.c. A)	2x26A	P
	a.c. output ratings:	See below	P
	- Voltage (nominal or range) (a.c.V)	400Vac	P
	- Current (maximum continuous) (a.c.A)	31.79A	P
	- Frequency (nominal or range) (Hz)	50Hz	P
	- Power (maximum continuous) (W or VA)	22000W	P
	- Power factor range	>0.99	P
	a.c input ratings:	No ac input used	N/A

TRF No. IS 16221 (Part 2): 2015_V1.0

HI PHYSIX LABORATORY INDIA PVT. LTD.
[Signature]
D. V. Awatade
(General Manager - Electronics Division)



TC-5100

IS 16221 (PART 2):2015			
Clause	Requirement + Test	Result - Remark	Verdict
	- Voltage (nominal or range) (a.c. V)	No ac input used	N/A
	- Current (maximum continuous) (a.c. A)	No ac input used	N/A
	- Frequency (nominal or range)(Hz)	No ac input used	N/A
	d.c. output ratings:	No dc output used	N/A
	- Voltage (nominal or range) (d.c. V)	No dc output used	N/A
	- Current (maximum continuous) (d.c. A)	No dc output used	N/A
	Protective class (I or II or III)	Class I	P
	Ingress protection (IP) rating per part 1	IP65	P
	An inverter that is adjustable for more than one nominal output voltage shall be marked to indicate the particular voltage for which it is set when shipped from the factory.	No such application	N/A
5.1.5/RD	Fuse identification	No fuse used	N/A
	Marking shall be located adjacent to each fuse or fuse holders, or on the fuse holders, or in another location provided that it is obvious to which fuse the marking applies, giving the fuse current rating and where fuses of different voltage rating value could be fitted, the fuse voltage rating.	See above	N/A
	Where fuses with special fusing characteristics such as time delay or breaking capacity are necessary, the type shall also be indicated	See above	N/A
	For fuses not located in operator access areas and for soldered-in fuses located in operator access areas, it is permitted to provide an unambiguous cross-reference (for example, F1, F2, etc.) to the servicing instructions which shall contain the relevant information.	See above	N/A
5.1.6/RD	Terminals, Connections, and Controls	See below	P
	If necessary for safety, an indication shall be given of the purpose of Terminals, connectors, controls, and indicators, and their various positions, including any connections for coolant fluids such as water and drainage. The symbols in Annex C may be used, and where there is insufficient space, symbol 9 of Annex C may be used.	Symbol 9 are marked on the EUT and user manual indicate the installation and safety of connection of connector, control and indicator	P
	Push-buttons and actuators of emergency stop devices, and indicator lamps used only to indicate a warning of danger or the need for urgent action shall be colored red.	No such devices used	N/A
	A multiple-voltage unit shall be marked to indicate the particular voltage for which it is set when shipped from the factory. The marking is allowed to be in the form of a paper tag or any other nonpermanent material.	The EUT is not intended to connect to multiple-voltage and there is no voltage setting device	N/A
	A unit with d.c. terminals shall be plainly marked indicating the polarity of the connections, with:	See below	P

TRF No. IS 16221 (Part 2): 2015_V1.0

HI PHYSIX LABORATORY INDIA PVT. LTD.
Anantade
(General Manager - Electronics Division)



TC-5100

IS 16221 (PART 2):2015

Clause	Requirement + Test	Result - Remark	Verdict
	– the sign “+” for positive and “-” for negative; or	The “+” and “-” marking were provided adjacent to the DC input terminals	P
	– a pictorial representation illustrating the proper polarity where the correct polarity can be unambiguously determined from the representation	No pictorial representation illustration used	N/A
5.1.6.1/RD	Protective Conductor Terminals	See below	P
	The means of connection for the protective earthing conductor shall be marked with:	See below	P
	– symbol 7 of Annex C; or	The symbol 7 of Annex C was marked adjacent to the PE terminal	P
	– the letters “PE”; or	Symbol 7 of Annex C was used	N/A
	– the colour coding green-yellow	Symbol 7 of Annex C was used	N/A
5.1.7/RD	Switches and circuit-breakers	See below	P
	The on and off-positions of switches and circuits breakers shall be clearly marked. If a push-button switch is used as the power switch, symbols 10 and 16 of Annex C may be used to indicate the on position, or symbols 11 and 17 to indicate the off position, with the pair of symbols (10 and 16, or 11 and 17) close together.	“ON” indicated the on-position of DC switch and “OFF” indicated the off-position of DC switch	P
5.1.8/RD	Class II Equipment	Class I equipment	N/A
	Equipment using Class II protective means throughout shall be marked with symbol 12 of Annex C. Equipment which is only partially protected by DOUBLE INSULATION or REINFORCED INSULATION shall not bear symbol 12 of Table Annex C.	See above cl. no. 5.1.8	N/A
	Where such equipment has provision for the connection of an earthing conductor for functional reasons (see 7.3.6.4) it shall be marked with symbol 6 of Annex C	See above cl. no. 5.1.8	N/A
5.1.9/RD	Terminal boxes for External Connections	See below	P
	Where required by note 1 of Table 2 as a result of high temperatures of terminals or parts in the wiring compartment, there shall be a marking, visible beside the terminal before connection, of either:	Complies	P
	a) the minimum temperature Rating and size of the cable to be connected to the TERMINALS; or	See below b)	N/A
	b) a marking to warn the installer to consult the installation instruction. Symbol 9 of Table D-1 is an acceptable marking	Symbol 9 marked on label	P
5.2	Warning markings	See below	P

HI PHYSIX LABORATORY INDIA PVT. LTD.
(Signature)
Awatade
(General Manager - Electronics Division)



TC-5100

IS 16221 (PART 2):2015

Clause	Requirement + Test	Result - Remark	Verdict
5.2.1/RD	Visibility and legibility requirements for warning markings	Warning markings are be Visible and legible.	P
	Warning markings shall be legible, and shall have minimum dimensions as follows:	See below	P
	- Printed symbols shall be at least 2.75 mm high	Complies	P
	-Printed text characters shall be at least 1.5 mm high and shall contrast in colour with the back ground	Complies	P
	-Symbols or text that are moulded, stamped or engraved in a material shall have a character height of at least 2.0 mm, and if not contrasting in colour from the background, shall have a depth or raised height of at least 0.5 mm.	No such symbols.	N/A
	If it is necessary to refer to the instruction manual to preserve the protection afforded by the equipment, the equipment shall be marked with symbol 9 of Annex C	The manual provides necessary information for the warning marking	P
	Symbol 9 of Annex C is not required to be used adjacent to symbols that are explained in the manual	All symbols are explained in the manual	P
5.2.2	Content for warning markings	See below	P
5.2.2.1/RD	Ungrounded heat sinks and similar parts	Grounded heat sink and similar parts	N/A
	An ungrounded heat sink or other part that may be mistaken for a grounded part and involves a risk of electric shock in accordance with 7.3 shall be marked with symbol 13 of Annex C, or equivalent. The marking maybe on or adjacent to heat sink and shall be clearly visible when the PCE is disassembled to the extent that a risk of contact with the heat sink exists.	See above	N/A
5.2.2.2/RD	Hot Surfaces	See below	P
	A part of the PCE that exceeds the temperature limits specified in 4.3.2 shall be marked with symbol 14 of Annex C or equivalent.	The symbol 14 of Annex C provided on the warning label	P
5.2.2.3/RD	Coolant	No coolant contained within the equipment	N/A
	A unit containing coolant that exceeds 70 °C shall be legibly marked externally where readily visible after installation with symbol 15 of Annex C. The documentation shall provide a warning regarding the risk of burns from hot coolant, and either:	See above cl. no. 5.2.2.3	N/A
	a) statement that coolant system servicing is to be done only by SERVICE PERSONNEL, or	See above cl. no. 5.2.2.3	N/A

TRF No. IS 16221 (Part 2): 2015_V1.0

HI PHYSIX LABORATORY INDIA PVT. LTD.

 Anurag Awasthi
 (General Manager - Electronics Division)



TC-5100

ULR-TC510022000000496F

Page 25 of 107

Report No. HPLI/Test/2204003501

IS 16221 (PART 2):2015			
Clause	Requirement + Test	Result - Remark	Verdict
	b) instructions for safe venting, draining, or otherwise working on the cooling system, if these operations can be performed without OPERATOR access to HAZARDS internal to the equipment	See above cl. no. 5.2.2.3	N/A
5.2.2.4/RD	Stored energy	See below	P
	Where required by 7.3.9.2 or 7.4.2 the PCE shall be marked with Symbol 21 of Annex C and the time to discharge capacitors to safe voltage and energy levels shall accompany the symbol.	Symbol 21 of annex C and "5min" were provided on the manual	P
5.2.2.5/RD	Motor guarding	No such devices	N/A
	Where required by 8.2 a marking shall be provided where it is visible to service personnel before removal of a guard, warning of the hazard and giving instructions for safe servicing (for example disconnection of the source before removing the guard).	See above	N/A
5.2.2.6	Inverters for closed electrical operating areas	Not located in closed electrical operating area	N/A
	Where required by 4.8.3.6, an inverter not provided with full protection against shock hazard on the PV array shall be marked with a warning that the inverter is only for use in a closed electrical operating area, and referring to the installation instructions.	See above cl.no. 5.2.2.6	N/A
5.2.3/RD	Sonic hazard markings and instructions	No sonic hazard	N/A
	If required by 10.2.1 a PCE shall:	See above cl. no. 5.2.3	N/A
	a) be marked to warn the operator of the sonic pressure hazard; or	See above cl. no. 5.2.3	N/A
	b) be provided with installation instructions that specify how the installer can ensure that the sound pressure level from equipment at its point of use after installation, will not reach a value, which could cause a hazard. These instructions shall include the measured sound pressure level, and shall identify readily available and practicable Protective materials or measures which may be used.	User manual provided that noise emission < 30dB	N/A
5.2.4/RD	Equipment with multiple sources of supply	No multiple source of supply used	N/A

TRF No. IS 16221 (Part 2): 2015_V1.0





TC-5100

IS 16221 (PART 2):2015			
Clause	Requirement + Test	Result - Remark	Verdict
	A PCE with connections for multiple energy sources shall be marked with symbol 13 of Annex C and the manual shall contain the information required in 5.3.4.	See above cl. no. 5.2.4	N/A
	The symbol shall be located on the outside of the unit or shall be prominently visible behind any cover giving access to hazardous parts.	See above cl. no. 5.2.4	N/A
5.2.5/RD	Excessive touch current	See below	P
	Where required by 7.3.6.3.7 the PCE shall be marked with symbol 15 of Annex C. See also 5.3.2 for information to be provided in the installation manual.	Symbol 15 of Annex C Provided on the marking plate.	P
5.3	Documentation	See below	P
5.3.1/RD	General	All related information's Provided in the user's manual.	P
	The documentation provided with the PCE shall provide the information needed for the safe operation, installation, and (where applicable) maintenance of the equipment. The documentation shall include the items required in 5.3.2 through 5.3.4, and the following:	See above cl. no. 5.3.1	P
	a) explanations of equipment makings, including symbols used	See above cl. no. 5.3.1	P
	b) location and function of terminals and controls	See above cl. no. 5.3.1	P
	c) all ratings or specifications that are necessary to safely install and operate the PCE, including the following environmental ratings along with an explanation of their meaning and any resulting installation requirements:	See above cl. no. 5.3.1	P
	-ENVIRONMENTAL CATEGORY as per 6.1	Outdoor used	P
	-WET LOCATIONS classification for the intended external environment as per 6.1	Yes	P
	-POLLUTION DEGREE classification for the intended external environment as per 6.2	PD2(Inside). PD3(Outside)	P
	-INGRESS PROTECTION rating as per 6.3	IP65	P
	-Ambient temperature and relative humidity ratings	(-25°C to (+)60°C, (0%-100%))	P
	-MAXIMUM altitude rating	3000m	P
	-OVERVOLTAGE CATEGORY assigned to each input and output port as per 7.3.7.1.2, accompanied by guidance regarding how to ensure that the installation complies with the required overvoltage categories;	PV side (OVCI), AC side (OVCIII)	P
	d) a warning that when the photovoltaic array is exposed to light, it supplies a d.c. voltage to the PCE	Considered	P
5.3.1.1/RD	Language	Instructions related to safety provided in english.	P
	Instructions related to safety shall be in a language that is acceptable in the country where the equipment is to be installed.	See above cl. No. 5.3.1.1	P
5.3.1.2/RD	Format	See below	P
	In general, the documentation must be provided in printed form and is to be delivered with the equipment.	Hardcopy provided with the equipment	P



TC-5100

IS 16221 (PART 2):2015			
Clause	Requirement + Test	Result - Remark	Verdict
	For equipment which requires the use of a computer for both installation and operation, documentation may be provided in electronic format without accompanying printed format.	Also provided in electronic format	P
5.3.2/RD	Information related to installation	All below related information's Provided in the user's manual.	P
	The documentation shall include installation and where applicable, specific commissioning instructions and, if necessary for safety, warnings against hazards which could arise during installation or commissioning of the equipment. The information provided shall include:	See above cl. no. 5.3.2	P
	a) assembly, location, and mounting requirements;	See above cl. no. 5.3.2	P
	b) ratings and means of connection to each source of supply and any requirements related to wiring and external controls, colour coding of leads, disconnection means, or overcurrent protection needed, including instructions that the installation position shall not prevent access to the disconnection means;	See above cl. no. 5.3.2	P
	c) ratings and means of connection of any outputs from the PCE, and any requirements related to wiring and external controls, colour coding of leads, or overcurrent protection needed;	See above cl. no. 5.3.2	P
	d) explanation of the pin-out of connectors for external connections, unless the connector is used for a standard purpose (e.g. RS 232)	See above cl. no. 5.3.2	P
	e) ventilation requirements;	See above cl. no. 5.3.2	P
	f) requirements for special services, for example cooling liquid;	No special service	N/A
	g) instructions and information relating to sound pressure level if required by 10.2.1;	No sound pressure hazard	N/A
	h) where required by 14.8.1.3, instructions for the adequate ventilation of the room or location in which PCE containing vented or valve regulated batteries is located, to prevent the accumulation of hazardous gases;	No battery used	N/A
	i) tightening torque to be applied to wiring terminals;	Provided	P
	j) Values of backfeed short-circuit currents available from the PCE on input and output conductors under fault conditions, if those currents exceed the max. rated current of the circuit, as per 4.4.4.6;	No backfeed short-circuit current	N/A
	k) for each input to the PCE, the max value of short-circuit current available from the source, for which the PCE is designed; and	Considered	P
	l) compatibility with RCD and RCM;	Provided	P
	m) instructions for protective earthing, including the information required by 7.3.6.3.7 if a second protective earthing conductor is to be installed;	Provided	P
	n) where required by 7.3.8, the installation instructions shall include the following or equivalent wording:	RCD is build in the EUT	N/A

TRF No. IS 16221 (Part 2): 2015_V1.0

HI PHYSIX LABORATORY INDIA PVT. LTD.
[Signature]
V. Awatade
(General Manager - Electronics Division)



TC-5100

IS 16221 (PART 2):2015			
Clause	Requirement + Test	Result - Remark	Verdict
	"This product can cause a d.c. current in the external protective earthing conductor. Where a residual current-operated protective (RCD) or monitoring (RCM) device is used for protection in a case of direct or indirect contact, only an RCD or RCM of Type B is allowed on the supply side of this product. "	See above	N/A
	o) for PCE intended to charge batteries, the battery nominal voltage rating, size, and type	No battery used	N/A
	p) PV array configuration information, such as ratings, whether the array is to be grounded or floating, any external protection devices needed, etc.	Information given in user manual	P
5.3.2.1	Ratings : Subclause 5.3.2 of Part 1 requires the documentation to include ratings information for each input and output. For inverters this information shall be as in Table 33 below. Only those ratings that are applicable based on the type of inverter are required.	See below	P
	PV input quantities:	See below	P
	- Vmax PV (absolute maximum) (d.c.V)	1000Vdc	P
	- PV input operating voltage range (d.c.V)	200-1000Vdc	P
	- Maximum operating PV input current (d.c. A)	2×26A	P
	- Isc PV (absolute maximum) (d.c. A)	2×40A	P
	- Max. inverter backfeed current to the array (a.c. or d.c. A)	0A	P
	a.c. output quantities:	See below	P
	- Voltage (nominal or range) (a.c.V)	400Vac	P
	- Current (maximum continuous) (a.c.A)	31.79A	P
	- Current (inrush) (a.c. A, peak and duration)	18.4A @ 0.214ms	P
	- Frequency (nominal or range) (Hz)	50Hz	P
	- Power (maximum continuous) (W or VA)	22000W	P
	- Power factor range	>0.99	P
	- Maximum output fault current (a.c. A, peak and duration or RMS)	39.6A @ 320us	P
	- Maximum output overcurrent protection (a.c.A)	32A	P
	a.c. input quantities:	No a.c input	N/A
	- Voltage (nominal or range) (a.c.V)	See above	N/A
	- Current (maximum continuous) (a.c.A)	See above	N/A
	- Current (inrush) (a.c. A, peak and duration)	See above	N/A
	- Frequency (nominal or range) (Hz)	See above	N/A
	d.c input (other than PV) quantities:	No d.c input	N/A
	- Voltage (nominal or range) (d.c.V)	See above	N/A
	- Nominal battery voltage (d.c.V)	See above	N/A
	- Current (maximum continuous) (d.c.A)	See above	N/A

TRF No. IS 16221 (Part 2): 2015_V1.0

HI PHYSIX LABORATORY INDIA PVT. LTD.

 (General Manager - Electronics Division)



TC-5100

IS 16221 (PART 2):2015			
Clause	Requirement + Test	Result - Remark	Verdict
	d.c. output quantities:	No d.c output	N/A
	- Voltage (nominal or range) (d.c.V)	See above	N/A
	- Nominal battery voltage (d.c.V)	See above	N/A
	- Current (maximum continuous) (d.c.A)	See above	N/A
	Protective class (I or II or III)	Class I	P
	Ingress protection (IP) rating per part 1	IP65	P
5.3.2.2	Grid-interactive inverter setpoints	See below	N/A
	For a grid-interactive unit with field adjustable trip points, trip times, or reconnect times, the presence of such controls, the means for adjustment, the factory default values, and the limits of the ranges of adjustability shall be provided in the documentation for the PCE or in other format such as on a website. Provided solution:	No adjustable setting available. Only the factory default values	N/A
	The setting of field adjustable setpoints shall be accessible from the PCE	See above	N/A
5.3.2.3	Transformers and isolation	Transformerless EUT	N/A
	Whether an internal isolation transformer is provided, and if so, what level of insulation (functional, basic, reinforced, or double) is provided by that transformer. The instructions shall also indicate what the resulting installation requirements are regarding such things as earthing or not earthing the array, providing external residual current detection devices, etc.	See above cl. no. 5.3.2.3	N/A
	An inverter shall be provided with information to the installer regarding:	See above cl. no. 5.3.2.3	N/A
	-providing of internal isolation transformer	See above cl. no. 5.3.2.3	N/A
	-the level of insulation (functional, basic, reinforced, or double)	See above cl. no. 5.3.2.3	N/A
	The instructions shall also indicate what the resulting Installation requirements are regarding:	See above cl. no. 5.3.2.3	N/A
	-earthing or not earthing the array	See above cl. no. 5.3.2.3	N/A
	-providing external residual current detection devices	See above cl. no. 5.3.2.3	N/A
	requiring an external isolation transformer,	See above cl. no. 5.3.2.3	N/A
5.3.2.4	Transformers required but not provided	Transformer less EUT	N/A
	An inverter that requires an external isolation transformer not provided with the unit, shall be provided with instructions that specify, and for the external isolation transformer with which it is intended to be used:	See above cl. no. 5.3.2.4	N/A
	-the configuration type	See above cl. no. 5.3.2.4	N/A
	-electrical ratings	See above cl. no. 5.3.2.4	N/A
	-environmental ratings	See above cl. no. 5.3.2.4	N/A



TC-5100

IS 16221 (PART 2):2015

Clause	Requirement + Test	Result - Remark	Verdict
	If the maximum AC mains operating voltage is higher than the PV array maximum system voltage then the instructions shall require PV modules that have a maximum system voltage rating based upon the AC mains voltage.	AC mains voltage not more than PV array maximum system voltage	N/A
5.3.2.5	PV modules for non-isolated inverters	See below	P
	Non-isolated inverters shall be provided with installation instructions that require PV modules that have an IEC 61730 Class A rating	Complies	P
5.3.2.6	Non-sinusoidal output waveform information	Grid connected inverter	N/A
	The instruction manual for a stand-alone inverter not complying with 4.7.5.2 shall include a warning that:	See above cl. no. 5.3.2.6	N/A
	- the waveform is not sinusoidal,	See above cl. no. 5.3.2.6	N/A
	- some loads may experience increased heating,	See above cl. no. 5.3.2.6	N/A
	-the user should consult the manufacturers of the intended load equipment before operating that load with the inverter	See above cl. no. 5.3.2.6	N/A
	The inverter manufacturer shall provide information regarding:	See above cl. no. 5.3.2.6	N/A
	-what types of loads may experience increased heating	See above cl. no. 5.3.2.6	N/A
	-recommendations for maximum operating times with such loads	See above cl. no. 5.3.2.6	N/A
	-The inverter manufacturer shall specify for the waveforms as determined by the testing in 4.7.5.3.2 through 4.7.5.3.4.:	See above cl. no. 5.3.2.6	N/A
	- THD	See above cl. no. 5.3.2.6	N/A
	- slope	See above cl. no. 5.3.2.6	N/A
	- peak voltage	See above cl. no. 5.3.2.6	N/A
5.3.2.7	Systems located in closed electrical operating areas	Not located in the closed electrical operating area	N/A
	Where required by 4.8.3.6, an inverter not provided with full protection against shock hazard on the PV array shall be provided with installation instructions:	See above cl. no. 5.3.2.7	N/A
	-requiring that the inverter and the array must be installed in closed electrical operating areas	See above cl. no. 5.3.2.7	N/A
	-indicating which forms of shock hazard protection are and are not provided integral to the inverter (for example the RCD, isolation transformer complying with the 30 mA touch current limit, or residual current monitoring for sudden changes)	See above cl. no. 5.3.2.7	N/A
5.3.2.8	Stand-alone inverter output circuit bonding	Grid connected inverter	N/A
	Where required by 7.3.10, the documentation for an inverter shall include the following:	See above cl. no. 5.3.2.8	N/A

TRF No. IS 16221 (Part 2): 2015_V1.0

HI PHYSIX LABORATORY INDIA PVT. LTD.
(Signature)
Awatade
(General Manager, Electronics Division)



TC-5100

IS 16221 (PART 2):2015			
Clause	Requirement + Test	Result - Remark	Verdict
	- if output circuit bonding is required but is not provided integral to the inverter, the required means shall be described in the installation instructions, including which conductor is to be bonded and the required current carrying capability or cross-section of the bonding means;	See above cl. no. 5.3.2.8	N/A
	- if the output circuit is intended to be floating, the documentation for the inverter shall indicate that the output is floating.	See above cl. no. 5.3.2.8	N/A
5.3.2.9	Protection by application of RCD's	See below	N/A
	Where the requirement for additional protection in 4.8.3.1 is met by requiring an RCD that is not provided integral to the inverter, as allowed by 4.8.3.4, the installation instructions shall state the need for the RCD	The RCD protection is integrated with inverter	N/A
	and shall specify its rating, type, and required circuit location	The RCD protection is integrated with inverter	N/A
5.3.2.10	Remote indication of faults	See below	P
	The installation instructions shall include an explanation of how to properly make connections to (where applicable), and use, the electrical or electronic fault indication required by 13.9.	Information provided in manual	P
5.3.2.11	External array insulation resistance measurement and response	Clause 4.8.2.1 complies	N/A
	The installation instructions for an inverter for use with ungrounded arrays that does not incorporate all the aspects of the insulation resistance measurement and response requirements in 4.8.2.1, must include:	EUT incorporates array insulation resistance measurement	N/A
	- for isolated inverters: an explanation of what aspects of array insulation resistance measurement and response are not provided, and	See above cl. no. 5.3.2.11	N/A
	- an instruction to consult local regulations to determine if any additional functions are required or not;	See above cl. no. 5.3.2.11	N/A
	- for non-isolated inverters: an explanation of what external equipment must be provided in the system, and	See above cl. no. 5.3.2.11	N/A
	- what the setpoints and response implemented by that equipment must be, and:	See above cl. no. 5.3.2.11	N/A
	- how that equipment is to be interfaced with the rest of the system.	See above cl. no. 5.3.2.11	N/A
5.3.2.12	Array functional grounding information	No functional grounding	N/A
	Where approach a) of 4.8.2.2 is used, the installation instructions for the inverter shall include all of the following:	See above cl. no. 5.3.2.12	N/A

TRF No. IS 16221 (Part 2): 2015_V1.0

HI PHYSIX LABORATORY INDIA PVT. LTD.
[Signature]
Apatade
(General Manager - Electronics Division)



TC-5100

IS 16221 (PART 2):2015

Clause	Requirement + Test	Result - Remark	Verdict
	a) the value of the total resistance between the PV circuit and ground integral to the inverter	See above cl. no. 5.3.2.12	N/A
	b) the minimum array insulation resistance to ground that system designer or installer must meet when selecting the PV panel and system design, based on the minimum value that the design of the PV functional grounding in the inverter was based on	See above cl. no. 5.3.2.12	N/A
	c) the minimum value of the total resistance $R = V_{MAX} PV/30 \text{ mA}$ that the system must meet, with an explanation of how to calculate the total	See above cl. no. 5.3.2.12	N/A
	d) a warning that there is a risk of shock hazard if the total minimum resistance requirement is not met.	See above cl. no. 5.3.2.12	N/A
5.3.2.13	Stand-alone inverters for dedicated loads	Grid connected inverter	N/A
	Where the approach of 4.7.5.5 is used, the installation instructions for the inverter shall include a warning that the inverter is only to be used with the dedicated load for which it was evaluated, and shall specify the dedicated load.	See above cl. no. 5.3.2.13	N/A
5.3.2.14	Identification of firmware version(s)	The firmware version is displayed on display screen	P
	An inverter utilizing firmware for any protective functions shall provide means to identify the firmware version.	See above cl. no. 5.3.2.14	P
	This can be a marking, but the information can also be provided by a display panel, communications port or any other type of user interface	See above cl. no. 5.3.2.14	P
5.3.3	Information related to operation	All below related information provided in the user's manual.	P
	Instructions for use shall include any operating instructions necessary to ensure safe operation, including the following, as applicable:	See above cl. no. 5.3.3	P
	- Instructions for adjustment of controls including the effects of adjustment;	See above cl. no. 5.3.3	P
	- Instructions for interconnection to accessories and other equipment, including indication of suitable accessories, detachable parts and any special materials;	See above cl. no. 5.3.3	P
	- Warnings regarding the risk of burns from surfaces permitted to exceed the temperature limits of 4.3.2 and required operator actions to reduce the risk; and	The temperature of the surfaces not exceed the limit of 4.3.2, however the symbol 14 marked on the label	N/A
	- Instructions, that if the equipment is used in a manner not specified by the manufacturer, the protection provided by the equipment may be impaired.	See above cl. no. 5.3.3	P

TRF No. IS 16221 (Part 2): 2015_V1.0

HI PHYSIX LABORATORY INDIA PVT. LTD.
[Signature]
(General Manager - Electronics Division)



TC-5100

ULR-TC510022000000496F

Page 33 of 107

Report No. HPLI/Test/2204003501

IS 16221 (PART 2):2015

Clause	Requirement + Test	Result - Remark	Verdict
5.3.4	Information related to maintenance	All below related information provided in the user's manual.	P
	Maintenance instructions shall include the following:	See above cl. no. 5.3.4	P
	- Intervals and instructions for any preventive maintenance that is required to maintain safety (for example air filter replacement or periodic re-tightening of terminals);	See above cl. no. 5.3.4	P
	- Instructions for accessing operator access areas, if any are present, including a warning not to enter other areas of the equipment;	See above cl. no. 5.3.4	P
	- Part numbers and instructions for obtaining any required operator replaceable parts;	No any operator replaceable Part.	N/A
	- Instructions for safe cleaning (if recommended)	See above cl. no. 5.3.4	P
	- Where there is more than one source of supply energizing the PCE, information shall be provided in the manual to indicate which disconnect device or devices are required to be operated in order to completely isolate the equipment.	Only single source of supply	N/A
5.3.4.1	Battery maintenance	The EUT is Grid-connected inverter without battery energy Storage function.	N/A
	Where required by 14.8.5, the documentation shall include the applicable items from the following list of instructions regarding maintenance of batteries:	See above cl. no. 5.3.4.1	N/A
	- Servicing of batteries should be performed or supervised by personnel knowledgeable about batteries and the required precautions	See above cl. no. 5.3.4.1	N/A
	- When replacing batteries, replace with the same type and number of batteries or battery packs	See above cl. no. 5.3.4.1	N/A
	- General instructions regarding removal and installation of batteries	See above cl. no. 5.3.4.1	N/A
	- CAUTION: Do not dispose of batteries in a fire. The batteries may explode.	See above cl. no. 5.3.4.1	N/A
	- CAUTION: Do not open or damage batteries. Released electrolyte is harmful to the skin and eyes. It may be toxic.	See above cl. no. 5.3.4.1	N/A
	- CAUTION: A battery can present a risk of electrical shock and high short-circuit current. The following precautions should be observed when working on batteries:	See above cl. no. 5.3.4.1	N/A
	a) Remove watches, rings, or other metal objects.	See above cl. no. 5.3.4.1	N/A
	b) Use tools with insulated handles.	See above cl. no. 5.3.4.1	N/A
	c) Wear rubber gloves and boots.	See above cl. no. 5.3.4.1	N/A
	d) Do not lay tools or metal parts on top of batteries	See above cl. no. 5.3.4.1	N/A
	e) Disconnect charging source prior to connecting or disconnecting battery terminals	See above cl. no. 5.3.4.1	N/A

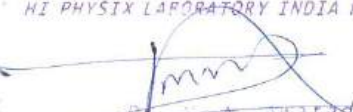
HI PHYSIX LABORATORY INDIA PVT. LTD.

 (General Manager - Electronics Division)

TRF No. IS 16221 (Part 2): 2015_V1.0



TC-5100

IS 16221 (PART 2):2015

Clause	Requirement + Test	Result - Remark	Verdict
	f) Determine if battery is inadvertently grounded. If inadvertently grounded, remove source from ground. Contact with any part of a grounded battery can result in electrical shock. The likelihood of such shock can be reduced if such grounds are removed during installation and maintenance (applicable to equipment and remote battery supplies not having a grounded supply circuit).	See above cl. no. 5.3.4.1	N/A
6	Environmental requirements and conditions	See below	P
6.1/RD	Environmental categories and minimum environmental conditions	See below	P
6.1.1/RD	Outdoor	EUT is for outdoor use	P
6.1.2/RD	Indoor, unconditioned	EUT is for outdoor use	N/A
6.1.3/RD	Indoor, conditioned	EUT is for outdoor use	N/A
6.2/RD	Pollution degree	PD3	P
6.3/RD	Ingress Protection	IP65	P
6.4/RD	UV exposure	Certified connector used outside the enclosure	P
6.5/RD	Temperature and humidity	(-25°C to 60°C), (0%-100%)	P
7	Protection against electric shock and energy hazards	See below	P
7.1/RD	General	Both normal and single fault condition considered	P
7.3	Protection against electric shock	See below	P
7.3.1/RD	General	See cl. no. 7.3.2.1	P
7.3.2/RD	Decisive voltage classification	See below	P
7.3.2.1/RD	Use of decisive voltage class (DVC)	Working voltage and protective measures are considered.	P
7.3.2.2/RD	Limits of DVC (according table 6)	Considered	P
7.3.2.3/RD	Short-terms limits of accessible voltages under fault conditions	Voltage not exceeding at DVC under fault	N/A
7.3.2.4/RD	Requirements for protection (according table 7)	Complies	P
7.3.2.5/RD	Connection to PELV and SELV circuits	The external signal communication interface are considered as SELV	P
7.3.2.6/RD	Working voltage and DVC	See below	P
7.3.2.6.1/RD	General	Considered	P
7.3.2.6.2/RD	AC working voltage (see Figure 2)	Considered	P
7.3.2.6.3/RD	DC working voltage (see Figure 3)	Considered	P
7.3.2.6.4/RD	Pulsating working voltage (see Figure 4)	Not considered	N/A
7.3.3/RD	Protective separation	See below	P
	Protective separation shall be achieved by:	See below	P
	- double or reinforced insulation, or	Double or reinforced insulation was provided	P

TRF No. IS 16221 (Part 2): 2015_V1.0

HI PHYSIX LABORATORY INDIA PVT. LTD.
(Signature)
D. Awatade
(Electronics Division)



TC-5100

ULR-TC510022000000496F

Page 35 of 107

Report No. HPLI/Test/2204003501

IS 16221 (PART 2):2015

Clause	Requirement + Test	Result - Remark	Verdict
	-protective screening, i.e. by a conductive screen connected to earth by protective bonding in the PCE, or connected to the protective earth conductor itself, where by the screen is separated from live parts by at least basic insulation, or	All accessible metal parts were earthed and separated from live parts by at least basic insulation	P
	-protective impedance comprising limitation of current per 7.3.5.3 and of discharged energy per 7.3.5.4, or	No such device	N/A
	-limitation of voltage according to 7.3.5.4.	No such device	N/A
	The protective separation shall be fully and effectively maintained under all conditions of intended use of the PCE	Complies	P
7.3.4/RD	Protection against direct contact	See below	P
7.3.4.1/RD	General	See below	P
	Protection against direct contact is employed to prevent persons from touching live parts that do not meet the requirements of 7.3.5 and shall be provided by one or more of the measure given in 7.3.4.2 (enclosures and barriers) and 7.3.4.3 (insulation).	Complies with the required of cl. No. 7.3.4.2 and 7.3.4.3.	P
	Open type sub-assemblies and devices do not require protective measures against direct contact but the instruction provided with the equipment must indicate that such measures must be provided in the end equipment or in the installation.	No such device	N/A
	Product intended for installation in CLOSED ELECTRICAL OPERATING AREAS, (see 3.9) need not have protective measures against direct contact, except as required by 7.3.4.2.4	No such device	N/A
7.3.4.2/RD	Protection by means of enclosures and barriers	See below	P
	The following requirements apply where protection against contact with live parts is provided by enclosures or barriers, not by insulation in accordance with 7.3.4.3.	Enclosure provided	P
7.3.4.2.1/RD	General	See below	P
	Parts of enclosures and barriers that provide protection in accordance with these requirements shall not be removable without the use of a tool (see 7.3.4.2.3).	Not removable without a tool and secured by screw.	P
	Polymeric materials used to meet these requirements shall also meet the requirements of 13.6	Certified connector used outside the enclosure and meeting the requirements of cl. 13.6.	P
7.3.4.2.2 / RD	Access probe criteria	See below	P
	Protection is considered to be achieved when the separation between the test probes and live parts, when tested as described below, is as follows:	Complies	P

TRF No. IS 16221 (Part 2): 2015_V1.0

HI PHYSIX LABORATORY INDIA PVT. LTD.

 Awatade
 (General Manager - Electronics Division)



TC-5100

IS 16221 (PART 2):2015

Clause	Requirement + Test	Result - Remark	Verdict
	a) decisive voltage classification A, (DVC A) - the probe may touch the live parts	The communication interface is considered as DVC A and probe may touch such parts.	P
	b) decisive voltage classification B, (DVC B) - the probe must not touch bare live parts	The DVC B circuit is not accessible by probe.	P
	c) decisive voltage classification C, (DVC C) – the probe must have adequate clearance to live parts, based on the clearance for Basic insulation using the recurring peak working voltage involved,	The DVC C circuit is not accessible by probe	P
7.3.4.2.3/R D	Access probe tests	See below	P
	Compliance with 7.3.4.2.1 is checked by all of the following:	Complies	P
	a) Inspection; and	Complies	P
	b) Tests with the test finger (Figure D.1) and test pin (Figure D.2) of annex D, the results of which shall comply with the requirements of 7.3.4.2.1 a), b), and c) as applicable. Probe tests are performed on openings in the enclosures after removal of parts that can be detached or opened by an operator without the use of a tool, including fuse holders, and with operator access doors and covers open. It is permitted to leave lamps in place for this test. Connectors that can be separated by an operator without use of a tool, shall also be tested during and after disconnection. Any movable parts are to be put in the most unfavorable position.	Complies	P
	The test finger and the test pin are applied as above, without appreciable force, in every possible position, except that floor-standing equipment having a mass exceeding 40 kg is not tilted	Complies	P
	Equipment intended for building-in or rack mounting, or for incorporation in larger equipment, is tested with access to the equipment limited according to the method of mounting detailed in the installation instructions.	Not a building-in and rack mounting equipment	N/A
	c) Openings preventing the entry of the jointed test finger (Figure E-1 of 0E) during test b) above, are further tested by means of straight un jointed test finger (Figure E-3 of 0E), applied with a force of 30 N. If the unjointed finger enters, the test with the jointed finger is repeated except that the finger is applied using any necessary force up to 30 N.	Complies	P
	d) In addition to a) – c) above, top surfaces of enclosure shall be tested with the IP3X probe of IEC 60529. The test probe shall not penetrate the top surface of the enclosure when probed from the vertical direction $\pm 5^\circ$ only.	Complies	P

HI PHYSIX LABORATORY INDIA PVT. LTD.

 (General Manager - Electronics Division)



TC-5100

IS 16221 (PART 2):2015

Clause	Requirement + Test	Result - Remark	Verdict
7.3.4.2.4/R D	Service access areas	The EUT is not allowed to remove the covers during installation and maintenance when EUT energized. Symbol 21 of Annex C are marked on EUT and explained in user manual.	N/A
7.3.4.3/RD	Protection by means of insulation of live parts	Complies	P
	Where the requirements of 7.3.4.2 are not met, live parts shall be provided with insulation if:	Communication ports provided with decisive voltage class A.	P
	– their working voltage is greater than the maximum limit of decisive voltage class A, or	See above	P
	– for a DVC A or B circuit, protective separation from adjacent circuit of DVC C is not provided (see note “†” under Table 7)	See above	P
7.3.5/RD	Protection in case of direct contact	See below	P
7.3.5.1/RD	General	See below	P
	Protection in case of direct contact is required to ensure that contact with live parts does not produce a shock hazard.	Complies	P
	The protection against direct contact according to 7.3.4 is not required if the circuit contacted is separated from other circuits according to 7.3.2.3, and:	See below	P
	– is of decisive voltage class A and complies with 7.3.5.2, or	Only DVC-A classified circuits can be touch directly	P
	– is provided with protective impedance according to 7.3.5.3, or	No such parts	N/A
	– is limited in voltage according to 7.3.5.4	No such parts	N/A
	In addition to the measures as given in 7.3.5.2 to 7.3.5.4, it shall be ensured that in the event of error or polarity reversal of connectors no voltages that exceed DVC A can be connected into a circuit with protective separation. This applies for example to plug-in-sub-assemblies or other plug-in devices which can be plugged-in without the use of a tool (key) or which are accessible without the use of a tool.	Complies	P
	Compliance is checked by visual inspection and trial insertion.	Complies	P
7.3.5.2/RD	Protection using decisive voltage class A	Complies	P
7.3.5.3/RD	Protection by means of protective impedance	No such parts	N/A
	Circuits and conductive parts do not require protection against direct contact if any connection to circuits of DVC-B or DVC-C is through protective impedance, and the accessible circuit or part is otherwise provided with protective separation from circuits of DVC-B or DVC-C according 7.3.3.	See above cl. no. 7.3.5.3	N/A

TRF No. IS 16221 (Part 2): 2015_V1.0

HI PHYSIX LABORATORY INDIA PVT. LTD.
(Signature)
General Manager - Electronics Division



TC-5100

IS 16221 (PART 2):2015

Clause	Requirement + Test	Result - Remark	Verdict
7.3.5.3.1/RD	Limitation of current through protective impedance	No such parts	N/A
	The current available through protective impedance to earth and between simultaneously accessible parts, measured at the accessible live parts, shall not exceed a value of 3.5 mA a.c. or 10 mA d.c. under normal and single-fault conditions.	See above cl. no. 7.3.5.3.1	N/A
7.3.5.3.2 /RD	Limitation of discharging energy through protective impedance	No such parts	N/A
	The discharging energy available between simultaneously accessible parts protected by protective impedance shall not exceed the charging voltage and capacitance limits given in Table 9, which applies to both wet and dry Locations, under normal and single fault conditions. Refer to figure 8.	See above cl. no. 7.3.5.3.2	N/A
7.3.5.4/RD	Protection by means of limited voltages	No such parts	N/A
	That portion of a circuit that has its voltage reduced to DVC-A by a voltage divider that complies with the following requirements, and that is otherwise provided with protective separation from circuits of DVC-B or DVC-C according to 7.3.3, does not require protection against direct contact.	See above cl. no. 7.3.5.4	N/A
	The voltage divider shall be designed so that under normal and single fault conditions, including faults in the voltage division circuit, the voltage across the output of the voltage divider does not exceed the limit for DVC-A.	See above cl. no. 7.3.5.4	N/A
	This type of protection shall not be used in case of protective class II or unearthed circuits, because it relies on protective earth being connected.	See above cl. no. 7.3.5.4	N/A
7.3.6/ RD	Protection against indirect contact	See below	P
7.3.6.1/ RD	General	See below	P
	Protection against indirect contact is required to prevent shock- hazardous current being accessible from conductive parts during an insulation failure. This protection shall comply with the requirements for protective class I (basic insulation plus protective earthing), class II (double or reinforced insulation) or class III (limitation of voltages)	Protective Class I.	P
	That part of a PCE meets the requirements of 7.3.6.2 and 7.3.6.3 is defined as protective class I	Class I	P
	That part of a PCE meets the requirements of 7.3.6.4 is defined as protective class II.	Class I	N/A
	That part of PCE which meets the requirements of decisive voltage class A and in which no hazardous voltages are derived, is defined as protective class III. No shock hazard is present in such circuits	Class I	N/A

HI PHYSIX LABORATORY INDIA PVT. LTD.
[Signature]
Anantade
(General Manager - Electronics Division)



TC-5100

IS 16221 (PART 2):2015

Clause	Requirement + Test	Result - Remark	Verdict
	Where protection against indirect contact is dependent on means provided during installation, the installation instructions shall provide details of the required means and shall indicate the associated hazards.	Information provided	P
7.3.6.2/ RD	Insulation between live parts and accessible conductive parts	See below	P
	Accessible conductive parts of equipment shall be separated from live parts by insulation meeting the requirements of Table 7 or by clearances as specified in 7.3.7.4 and creepages as specified in 7.3.7.5	Complies. See Cl. 7.3.7.4 and Cl. 7.3.7.5	P
7.3.6.3 / RD	Protective class I – Protective bonding and earthing	See below	P
7.3.6.3.1/ RD	General	See below	P
	Equipment of protective class I shall be provided with protective earthing, and with protective bonding to ensure electrical contact between accessible conductive parts and the means of connection for the external protective earthing conductor, except bonding is not required for:	External protective earthing is to be connected to terminal near AC terminal block, and an second protective earthing conductor is bonded to metal case, refer to installation manual	P
	a) accessible conductive parts that are protected by one of the measures in 7.3.5.2 to 7.3.5.4, or	DVC A circuit considered	P
	b) accessible conductive parts are separated from live parts of DVC-B or -C using double or reinforced insulation.	Communication circuit are separated from live parts used doubled or reinforced insulation	P
7.3.6.3.2/R D	Requirements for protective bonding	See below	P
	Electrical contact with the means of connection of the external protective earthing conductor shall be achieved by one or more of the following means:	See below	P
	a) through direct metallic contact;	The connection of external protective earthing conductor is direct metal contact via terminal with screw.	P
	b) through other conductive parts which are not removed when the PCE or sub-units are used as intended;	See above a)	N/A
	c) through a dedicated protective bonding conductor;	Complies	P
	d) through other metallic components of the PCE	Complies	P
	Where direct metallic contact is used and one or both of the parts involved is painted or coated, the paint or coating shall be removed in the area of contact, or reliably penetrated, to ensure metal to metal contact.	No painted and coated	P
	For moving or removable parts, hinges or sliding contacts designed and maintained to have a low resistance are examples of acceptable means if they comply with the requirements of 7.3.6.3.3.	No such parts	N/A

TRF No. IS 16221 (Part 2): 2015_V1.0

HI PHYSIX LABORATORY INDIA PVT. LTD.
(Signature)
Awatade
(General Manager - Electronics Division)



TC-5100

IS 16221 (PART 2):2015

Clause	Requirement + Test	Result - Remark	Verdict
	Metal ducts of flexible or rigid construction and metallic sheaths shall not be used as protective bonding conductors, unless the device or material has been investigated as suitable for protective bonding purposes.	No such parts	N/A
7.3.6.3.3/ RD	Rating of protective bonding	See below	P
	Protective bonding shall withstand the highest thermal and dynamic stresses that can occur to the PCE item(s) concerned when they are subjected to a fault connecting live parts to accessible conductive parts. The protective bonding shall remain effective for as long as a fault to the accessible conductive parts persists or until an upstream Protective device removes power from the part.	Complies	P
	Protective bonding shall meet following requirements:	See below	P
	a) For PCE with an over current protective device rating of 16 A or less, the impedance of the protective bonding means shall not exceed 0.1 Ω during or at the end of the test below	>16A	N/A
	b) For PCE with an overcurrent protective device rating of morethan16A, the voltage drop in the protective bonding test shall not exceed 2,5 V during or at the end of the test below.	Complies (see appended table 7.3.6.3.3)	P
	As alternative to a) and b) the protective bonding may designed according to the requirements for the external Protective earthing conductor in 7.3.6.3.5, in which case no testing is required.	Above test is carried out	N/A
	The impedance of protective bonding means shall be checked by passing a test current through the bond for a period of time as specified below. The test current is based on the rating of the overcurrent protection for the equipment or part of the equipment under consideration, as follows:	Complies	P
	a) For pluggable equipment type A, the overcurrent protective device is that provided external to the equipment (for example, in the building wiring, in the mains plug or in an equipment rack);	Not a pluggable equipment type A	N/A
	b) For pluggable equipment type B and fixed equipment, the maximum rating of the overcurrent protective device specified in the equipment installation instructions to be provided external to the equipment;	Not a pluggable equipment type B	N/A
	c) For a circuit or part of the equipment for which an overcurrent protective device is provided as part of the equipment, the rating of the provided overcurrent device.	Complies	P
7.3.6.3.3.1 /RD	Test current, duration, and acceptance criteria	See below	P
	The test current, duration of the test and acceptance criteria are as follows:	See below	P

TRF No. IS 16221 (Part 2): 2015_V1.0

HI PHYSIX LABORATORY INDIA PVT. LTD.
(Signature)
Awatade
(General Manager - Electronics Division)



TC-5100

ULR-TC510022000000496F

Page 41 of 107

Report No. HPLI/Test/2204003501

IS 16221 (PART 2):2015

Clause	Requirement + Test	Result - Remark	Verdict
	a) For PCE with an overcurrent protective device rating of 16 A or less, the test current is 200% of the overcurrent protective device rating, but not less than 32 A, applied for 120s. The impedance of the protective bonding means during and at the end of the test shall not exceed 0,1 Ω .	See below b)	N/A
	b) For PCE with an overcurrent protective device rating of more than 16 A, the test current is 200% of the overcurrent protective device rating and the duration of the test is as shown in Table 10 below. The voltage drop in the protective bonding means, during and at the end of the test, shall not exceed 2,5 V.	Complies (see appended table 7.3.6.3.3)	P
	c) During and after the test, there shall be no melting, loosening, or other damage that would impair the effectiveness of the protective bonding means.	The EUT passed the test after the requirements of this standard.	P
	The test current is derived from an a.c or d.c supply source, the output of which is not earthed.	Complies	P
	As an alternative to Table 10, where the time current characteristic of the overcurrent protective device that limits the fault current in the protective bonding means is known because the device is either provided in the equipment or fully specified in the installation instructions, the test duration may be based on that specific device's time-current characteristic,. The tests are conducted for a duration corresponding to the 200% current value on the time-current characteristic.	No such application	N/A
7.3.6.3.4/R D	Protective bonding impedance (routine test)	Above test is carried out	N/A
	If the continuity of the protective bonding is achieved at any point by a single means only (for example a single conductor or single fastener), or if the PCE is assembled at the installation location, then the impedance of the protective bonding shall also be tested as a routine test. The test shall be as in 7.3.6.3.3, except for the following:	See above cl. no. 7.3.6.3.4	N/A
	- the test current may be reduced to any convenient value greater than 10 A sufficient to allow measurement or calculation of the impedance of the protective bonding means:	See above cl. no. 7.3.6.3.4	N/A
	- the test duration may be reduced to no less than 2s	See above cl. no. 7.3.6.3.4	N/A
	For equipment subject to the type test in 7.3.6.3.3.1a), the impedance during the routine test shall not exceed 0,1 Ω .	See above cl. no. 7.3.6.3.4	N/A
	For equipment subject to the type test in 7.3.6.3.3.1b) the impedance during the routine test shall not exceed 2,5 V divided by the test current required by 7.3.6.3.3.1b).	See above cl. no. 7.3.6.3.4	N/A
7.3.6.3.5/ RD	External protective earthing conductor	See below	P

TRF No. IS 16221 (Part 2): 2015_V1.0

HI PHYSIX LABORATORY INDIA PVT. LTD.

 Testing Engineer (Electronics Division)



TC-5100

IS 16221 (PART 2):2015			
Clause	Requirement + Test	Result - Remark	Verdict
	A protective earthing conductor shall be connected at all times when power is supplied to PCE of protective class I. Unless local wiring regulations state otherwise, the protective earthing conductor cross-sectional area shall be determined from Table 11 or by calculation according to IEC 60364-5-54.	Instruction regarding connection of earthing conductor provided in user manual.	P
	If the external protective earthing conductor is routed through a plug and socket or similar means of disconnection, it shall not be possible to disconnect it unless power is simultaneously removed from the part to be protected.	No such construction.	N/A
	- 2.5 mm ² if mechanical protection is provided;	See below	N/A
	- 4 mm ² if mechanical protection is not provided.	Refer user manual.	P
	For cord-connected equipment, provisions shall be made so that the external protective earthing conductor in the cord shall, in the case of failure of the strain-relief mechanism, be the last conductor to be interrupted.	Not a cord-connected equipment	N/A
7.3.6.3.6/ RD	Means of connection for the external protective earthing conductor	External protective earthing conductor connected to enclosure body	P
7.3.6.3.6.1 / RD	General	Properly connected	P
	The means of connection for the protective earthing conductor shall be permanently marked with:	See below	P
	- symbol 7 of Annex C; or	Earthing symbol marked "⊕"	P
	- the colour coding green-yellow	See above	N/A
	Marking shall not be done on easily changeable parts such as screws.	Complies	P
7.3.6.3.7/ RD	Touch current in case of failure of the protective earthing conductor	See below	P
	For pluggable equipment type A, the touch current measured in accordance with 7.5.4 shall not exceed 3.5mA a.c. or mA d.c.	Not a pluggable equipment type A	P
	For all other PCE, one or more of the following measure shall be applied, unless the touch current measured in accordance with 7.5.4 using the test network of IEC 60990 test figure 4 shall not exceed 3.5 mA a.c. or 10 mA d.c.	Not exceeding the limit of 3.5mA ac. (See appended table 7.3.6.3.7)	P
	a) Permanently connected wiring, and:	See above	N/A
	-a cross-section of the protective earthing conductor of at least 10 mm ² Cu or 16 mm ² Al; or	See above	N/A
	-automatic disconnection of the supply in case of discontinuity of the protective earthing conductor; or	See above	N/A

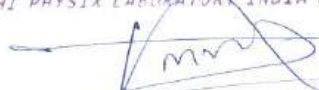
HI PHYSIX LABORATORY INDIA PVT. LTD.

 M. V. Awatade
 (General Manager - Electronics Division)



TC-5100

IS 16221 (PART 2):2015			
Clause	Requirement + Test	Result - Remark	Verdict
	-provision of an additional terminal for a second protective earthing conductor of the same cross-sectional area as the original protective earthing conductor and installation instruction requiring a second protective earthing conductor to be installed or	See above	N/A
	b) Connection with an industrial connector according to IEC 60309 and a minimum protective earthing conductor cross-section of 2,5 mm ² as part of a multi-conductor power cable. Adequate strain relief shall be provided.	See above	N/A
7.3.6.4/ RD	Protective Class II – Double or Reinforced Insulation	Protective Class I	N/A
	Equipment or parts of equipment designed for protective class II shall have insulation between live parts and accessible surfaces in accordance with 7.3.4.3. The following requirements also apply:	No such application	N/A
	-Equipment designed to protective class II shall not have means of connection for the external protective earthing conductor. However this does not apply if the external protective earthing conductor is passed through the equipment to equipment series-connected beyond it. In the latter event, the external protective earthing conductor and its means for connection shall be insulated with basic insulation from the accessible surface of the equipment and from circuits that employ protective separation, extra-low voltage, protective impedance and limited discharging energy, according to 7.3.5. This basic insulation shall correspond to the rated voltage of the series-connected equipment;	No such application	N/A
	-metal-encased equipment of protective class II may have provision on its enclosure for the connection of an equipotential bonding conductor;	No such application	N/A
	-equipment of protective class II may have provision for the connection of an earthing conductor for functional reasons or for damping of overvoltages; it shall, however, be insulated as though it is a live part;	No such application	N/A
	-Equipment employing protective class II shall be marked according to 5.1.8.	No such application	N/A
7.3.7/RD	Insulation Including Clearance and Creepage Distance	See below	P
7.3.7.1/RD	General	Considered	P
	Insulation shall be selected after consideration of the following influences:	Considered	P
	pollution degree	PD3	P
	overvoltage category	The mains circuit: III, PV circuit: II	P
	supply earthing system	For TN system only.	P
	insulation voltage	Considered	P

TRF No. IS 16221 (Part 2): 2015_V1.0

HI PHYSIX LABORATORY INDIA PVT. LTD.
(Signature)
N. Awatade
(General Manager - Electronics Division)



TC-5100

IS 16221 (PART 2):2015			
Clause	Requirement + Test	Result - Remark	Verdict
	location of insulation	Considered	P
	type of insulation	Considered	P
	Compliance of insulation, creepage distances, and clearance distances, shall be verified by measurement or visual inspection, and the tests of 7.5.	Considered	P
7.3.7.1.3/RD	Supply earthing systems	See below	P
	Three basic types of earthing system are described in IEC 60364-1. They are:	See below	P
	TN system: has one point directly earthed, the accessible conductive parts of the installation being connected to that point by protective conductors. Three types of TN systems, TN-C, TN-S and TN-C-S, are defined according to the arrangement of the neutral and protective conductor.	For TN system only	P
	TT system: has one point directly earthed, the accessible conductive parts of the installation being connected to earth electrodes electrically independent of the earth electrodes of the power system;	See above	N/A
	IT system: has all live parts isolated from earth or one point connected to earth through an impedance, the accessible conductive parts of the installation being earthed independently or collectively to the earthing system.	See above	N/A
7.3.7.1.4 /RD	Insulation voltages	PV supply circuits: 6000V (VMAX PV: 1000VDC) AC mains circuits: 4000V (Rated: 400VAC)	P
7.3.7.2/RD	Insulation between a circuit and its surroundings	See below	P
7.3.7.2.1 /RD	General	Considered	P
7.3.7.2.2 /RD	Circuits connected directly to the mains	Clearances and solid insulation required according to the impulse voltage, temporary overvoltage, or working voltage, whichever gives the most severe requirement.	P
7.3.7.2.3/ RD	Circuits other than mains circuits	Clearances and solid insulation required according to the impulse voltage and recurring peak voltage.	P
7.3.7.2.4/RD	Insulation between circuit	Clearances and solid insulation according to the higher impulse voltages. Creepages according to the r.m.s. working voltage.	P

TRF No. IS 16221 (Part 2): 2015_V1.0

HI PHYSIX LABORATORY INDIA PVT. LTD.
(Handwritten signature)
HPLI
(General Manager - Electronics Division)



TC-5100

ULR-TC510022000000496F

Page 45 of 107

Report No. HPLI/Test/2204003501

IS 16221 (PART 2):2015			
Clause	Requirement + Test	Result - Remark	Verdict
7.3.7.3/ RD	Functional insulation	Considered	P
7.3.7.4/RD	Clearance distances	See appended table 7.3.7.4	P
7.3.7.4.1/R D	Determination	Altitude: 3000m.	P
7.3.7.4.2 /RD	Electric field homogeneity	Not considered	N/A
7.3.7.4.3/R D	Clearance to conductive enclosures	Refer to subclause 7.3.7.4.1 and 13.7.	P
7.3.7.5/RD	Creepage distances	See appended table 7.3.7.5	P
7.3.7.5.1 /RD	General	See below	P
7.3.7.5.2 / RD	Voltage	The max. voltage: 400Vac, 1000Vd.c	P
7.3.7.5.3/ RD	Materials	Insulating material group IIIb	P
7.3.7.6/ RD	Coating	No such parts	N/A
7.3.7.7/ RD	PWB spacings for functional insulating	Certified PCB used	P
7.3.7.8/ RD	Solid insulating	Certified component used	P
7.3.7.8.1/ RD	General	See above cl. no. 7.3.7.8	P
7.3.7.8.2/ RD	Requirements for electrical withstand capability of solid insulation	See below	P
7.3.7.8.2.1 / RD	Basic, supplemental, reinforced, and double insulation	Passed the impulse withstand voltage and a.c. or d.c. voltage tests. (See appended table 7.5.1, 7.5.2 & 7.5.3)	P
7.3.7.8.2.2 / RD	Functional insulation	Complies	P
7.3.7.8.3/ RD	Thin sheet or tape material	See below	P
7.3.7.8.3.1 /RD	General	The transformer primary and secondary windings were separated by thin insulation sheet	P
7.3.7.8.3.2 / RD	Material thickness not less than 0.2 mm	See appended table 7.3.7	P
7.3.7.8.3.3 / RD	Material thickness less than 0.2 mm	Not used.	N/A
7.3.7.8.3.4 / RD	Compliance	See appended table 7.5.1, 7.5.2 & 7.5.3	P
7.3.7.8.4/ RD	Printed wiring boards	Certified PCB used	P
7.3.7.8.4.1 / RD	General	See above cl. no. 7.3.7.8.4	P

TRF No. IS 16221 (Part 2): 2015_V1.0

HI PHYSIX LABORATORY INDIA PVT. LTD.
Anatade
(Corporate Building - Electronics Division)



TC-5100

ULR-TC510022000000496F

Page 46 of 107

Report No. HPLI/Test/2204003501

IS 16221 (PART 2):2015

Clause	Requirement + Test	Result - Remark	Verdict
7.3.7.8.4.2 / RD	Use of coating materials	No coating material used.	N/A
7.3.7.8.5/ RD	Wound components	No such wound components.	N/A
7.3.7.8.6/ RD	Potting materials	No potting material used	N/A
7.3.7.9/ RD	Insulation requirements above 30 kHz	Considered	P
7.3.8/ RD	Residual Current-operated protective (RCD) or monitoring (RCM) device compatibility	The RCD is inbuilt within EUT	P
7.3.9/ RD	Protection against shock hazard due to stored energy	Considered	P
7.3.9.1/ RD	Operator access area	See below	P
	Equipment shall be so designed that there is no risk of electric shock in operator access areas from charge stored on capacitors after disconnection of the PCE.	The pins of connector cannot be touch by test finger due to design protection	P
7.3.9.2/RD	Service access areas	See below	P
	Capacitors located behind panels that are removable for servicing, installation, or disconnection shall present no risk of electric shock or energy hazard from charge stored on capacitors after disconnection of the PCE.	Complies	P
7.3.10	Additional requirements for stand-alone inverters	Not a stand-alone inverter	N/A
	One circuit conductor bonded to earth to create a grounded conductor and an earthed system.	See above cl. no. 7.3.10	N/A
	The means used to bond the grounded conductor to protective earth provided within the inverter or as part of the installation	See above cl. no. 7.3.10	N/A
	If not provided integral to the inverter, the required means shall be described in the installation instructions as per 5.3.2.8.	See above cl. no. 7.3.10	N/A
	The means used to bond the grounded conductor to protective earth shall comply with the requirements for protective bonding in Part 1,	See above cl. no. 7.3.10	N/A
	If the bond can only ever carry fault currents in stand-alone mode, the maximum current for the bond is determined by the inverter maximum output fault current.	See above cl. no. 7.3.10	N/A
	Output circuit bonding arrangements shall ensure that in any mode of operation, the system only has the grounded circuit conductor bonded to earth in one place at a time..	See above cl. no. 7.3.10	N/A
	Switching arrangements may be used, in which case the switching device used is to be subjected to the bond impedance test along with the rest of the bonding path	See above cl. no. 7.3.10	N/A

TRF No. IS 16221 (Part 2): 2015_V1.0

HI PHYSIX LABORATORY INDIA PVT. LTD.

 (General Manager - Electronics Division)



TC-5100

IS 16221 (PART 2):2015

Clause	Requirement + Test	Result - Remark	Verdict
	Inverters intended to have a circuit conductor bonded to earth shall not impose any normal current on the bond except for leakage current.	See above cl. no. 7.3.10	N/A
	Outputs that are intentionally floating with no circuit conductor bonded to ground, must not have any voltages with respect to ground that are a shock hazard in accordance with Clause 7 of Parts 1 and 2.	See above cl. no. 7.3.10	N/A
	The documentation for the inverter shall indicate that the output is floating as per 5.3.2.8.	See above cl. no. 7.3.10	N/A
7.3.11	Functionally grounded arrays	No such parts	N/A
	All PV conductors in a functionally grounded array shall be treated as being live parts with respect to protection against electric shock.	No such parts	N/A
7.4/RD	Protection against energy hazards	See below	P
7.4.1/RD	Determination of hazardous energy level	Hazardous energy level not present.	N/A
	A hazardous energy level is considered to exist if	See below	N/A
	a) The voltage is 2 V or more, and power available after 60 s exceeds 240 VA.	No such hazardous energy level exist.	N/A
	b) The stored energy in a capacitor is at a voltage. U of 2 V or more, and the stored energy. E, calculated from the following equation, exceeds 20J: $E = 0.5 CU^2$	No such hazardous energy level exist.	N/A
7.4.2/ RD	Operator Access Areas	See below	P
	Equipment shall be so designed that there is no risk of energy hazard in operator access areas from accessible circuits.	All hazardous energy parts were enclosed within earthed heat sink	P
7.4.3/ RD	Services Access Areas	The symbol 21 of annex C was provided on the label	P
7.5/ RD	Electrical tests related to shock hazard	See below	P
7.5.1/ RD	Impulse voltage test (type test)	During the test no puncture, flashover, or sparkover occurs. (See appended table 7.5)	P
7.5.2/ RD	Voltage test (dielectric strength test)	See below	P
7.5.2.1 / RD	Purpose of test	To verify the clearances and solid insulation and of assembled PCE has adequate dielectric strength to resist overvoltage's.	P
7.5.2.2/ RD	Value and type of test voltage	See appended table 7.5	P
7.5.2.3/ RD	Humidity pre-conditioning	Test performed as per cl. no. 4.5	P
7.5.2.4 / RD	Performing the voltage test	See appended table 7.5	P

TRF No. IS 16221 (Part 2): 2015_V1.0

HI PHYSIX LABORATORY INDIA PVT. LTD.
(Signature)
Awarade
(General Manager - Electronics Division)



TC-5100

IS 16221 (PART 2):2015

Clause	Requirement + Test	Result - Remark	Verdict
7.5.2.5/ RD	Duration of the a.c. or d.c. voltage test	Tested for 60s	P
7.5.2.6/ RD	Verification of the a.c. or d.c. voltage test	No electrical breakdown occurs and no abnormal current flow during the test	P
7.5.3/ RD	Partial discharge test	Certified component used	P
7.5.4/ RD	Touch current measurement (type test)	See below	P
	The touch current shall be measured if required by 7.3.6.3.7 and shall not be greater than 3.5 mA a.c. or 10 mA d.c. or special measures of protection as given in 7.3.6.3.7 are required.	See appended table 7.3.6.3.7	P
	For type tests on PCE for which wet locations requirements apply according to 6.1, the humidity pre-conditioning of 4.5 shall be performed immediately prior to the touch current test.	See appended table 7.3.6.3.7	P
7.5.5/RD	Equipment with multiple sources of supply	No multiple source of supply used	N/A
8	Protection against mechanical hazards	See below	P
8.1/ RD	General	See below	P
	Operation shall not lead to a mechanical HAZARD in NORMAL CONDITION or SINGLE FAULT CONDITION. Edges, projections, corners, openings, guards, handles and the like, that are accessible to the operator shall be smooth and rounded so as not to cause injury during normal use of the equipment.	No mechanical hazards under normal and single Fault condition	P
	Conformity is checked as specified in 8.2 to 8.6.	See 8.2 to 8.6	P
8.2/ RD	Moving parts	See below	P
	Moving parts shall not be able to crush, cut or pierce parts of the body of an OPERATOR likely to contact them, nor severely pinch the OPERATOR's skin. Hazardous moving parts of equipment, that is moving parts which have the potential to cause injury, shall be so arranged, enclosed or guarded as to provide adequate protection against the risk of personal injury.	No moving parts are accessible from outside	P
8.2.1/ RD	Protection of service persons	No such parts	N/A
	Protection shall be provided such that unintentional contact with hazardous moving parts is unlikely during servicing operations. If a guard over a hazardous moving part may need to be removed for servicing, the marking of symbol 15 of Table D-1 shall be applied on or near the guard.	See above cl.no. 8.2.1	N/A
8.3/ RD	Stability	The EUT for wall mounting	N/A
	Equipment and assemblies of equipment not secured to the building structure before operation shall be physically stable in NORMAL USE.	See above cl.no. 8.3	N/A

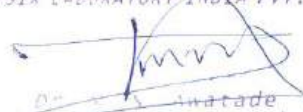
HI PHYSIX LABORATORY INDIA PVT. LTD.

 (General Manager - Electronics Division)

TRF No. IS 16221 (Part 2): 2015_V1.0



TC-5100

IS 16221 (PART 2):2015

Clause	Requirement + Test	Result - Remark	Verdict
8.4/ RD	Provisions for lifting and carrying	See below	P
	If carrying handles or grips are fitted to, or supplied with, the equipment, they shall be capable of withstanding a force of four times the weight of the equipment.	After the test there shall not be break loose from the equipment and there shall not be any permanent distortion, cracking or other evidence of failure	P
	Equipment or parts having a mass of 18 kg or more shall be provided with a means for lifting and carrying or directions shall be given in the manufacturer's documentation.	Refer user manual	P
8.5/ RD	Wall mounting	See below	P
	Mounting brackets on equipment intended to be mounted on a wall or ceiling shall withstand a force of four times the weight of the equipment.	No any damage after the test	P
8.6/RD	Expelled parts	See below	N/A
	Equipment shall contain or limit the energy of parts that could cause a HAZARD if expelled in the event of a fault.	No such parts	N/A
9	Protection against fire hazards	See below	P
9.1/ RD	Resistance to fire	Considered	P
	This subclause specifies requirements intended to reduce the risk of ignition and the spread of flame, both within the equipment and to the outside, by the appropriate use of materials and components and by suitable construction.	Components are verified at normal and abnormal tests	P
9.1.1/RD	Reducing the risk of ignition and spread of flame	Use of material with required flammability classes	P
	For equipment or a portion of equipment, there are two alternative methods of providing protection against ignition and spread of flame that could affect materials, wiring, wound components and electronic components such as integrated circuits, transistors, thyristors, diodes, resistors and capacitors.	Method 1 is used	P
9.1.2/RD	Conditions for a fire enclosure	See below	P
	A FIRE ENCLOSURE is required for equipment or parts of equipment for which Method 2 is not fully applied and complied with.	Fire enclosure is used	P
9.1.2.1/ RD	Parts requiring a fire enclosure	See below	P
	-Except where Method 2 is used, or as permitted in 9.1.2.2, the following are considered to have a risk of ignition and, therefore, require a FIREENCLOSURE:	Considered	P
	-components in PRIMARY CIRCUITS	Considered	P
	-components in SECONDARY CIRCUITS supplied by power sources which exceed the limits for a LIMITED POWER SOURCE as specified in 9.2;	No secondary circuits which exceed the limit present	N/A
	-components in SECONDARY CIRCUITS supplied by a LIMITED POWER SOURCE as specified in 9.2, but not mounted on a material of FLAMMABILITY CLASS V-1;	See list of critical components	P

TRF No. IS 16221 (Part 2): 2015_V1.0

HI PHYSIX LABORATORY INDIA PVT. LTD.

 (General Manager - Electronics Division)



TC-5100

ULR-TC510022000000496F

Page 50 of 107

Report No. HPLI/Test/2204003501

IS 16221 (PART 2):2015			
Clause	Requirement + Test	Result - Remark	Verdict
	-components within a power supply unit or assembly having a limited power output complying with the criteria for a LIMITED POWER SOURCE as specified in 9.2, including overcurrent protective devices, limiting impedances, regulating networks and wiring, up to the point where the LIMITED POWER SOURCE output criteria are met;	No such devices	N/A
	-components having unenclosed arcing parts, such as open switch and relay contacts and commutators, in a circuit at HAZARDOUS VOLTAGE or at a HAZARDOUS ENERGY LEVEL; and	No such devices	N/A
	-insulated wiring, except as permitted in 9.1.2.2	No such devices	N/A
9.1.2.2/ RD	Parts not requiring a fire enclosure	The EUT requires Fire enclosure	N/A
9.1.3/RD	Materials requirements for protection against fire hazard	See below	P
9.1.3.1/RD	General	See below	P
	ENCLOSURES, components and other parts shall be so constructed, or shall make use of such materials, that the propagation of fire is limited.	Metal enclosure and certified components used.	P
9.1.3.2/ RD	Materials for fire enclosures	Metal enclosure is used.	P
	If an enclosure material is not classified as specified below, a test may be performed on the final enclosure or part of the enclosure, in which case the material shall additionally be subjected to periodic SAMPLE testing.	See above cl.no. 9.1.3.2	P
9.1.3.3/ RD	Materials for components and other parts inside fire enclosures	Certified component used	P
9.1.3.5/ RD	Materials for air filter assemblies	No such material used	N/A
9.1.4/ RD	Openings in fire enclosures	No opening in fire enclosure	N/A
9.1.4.1/ RD	General	See above cl. no. 9.1.4.1	N/A
	For equipment that is intended to be used or installed in more than one orientation as specified in the product documentation, the following requirements apply in each orientation.	See above cl.no. 9.1.4.1	N/A
	These requirements are in addition to those in the following sections:	See above cl.no. 9.1.4.1	N/A
	- 7.3.4, Protection against direct contact;	See above cl.no. 9.1.4.1	N/A
	- 7.4, Protection against energy hazards;	See above cl.no. 9.1.4.1	N/A
	- 13.5, Openings in enclosures	See above cl.no. 9.1.4.1	N/A
9.1.4.2 / RD	Side openings treated as bottom openings	No side opening	N/A
9.1.4.3/ RD	Openings in the bottom of a fire enclosure	No bottom opening	N/A

TRF No. IS 16221 (Part 2): 2015_V1.0

HI PHYSIX LABORATORY INDIA PVT. LTD.

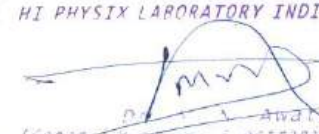

P. V. Awatade
(General Manager - Electronics Division)



TC-5100

ULR-TC510022000000496F

Page 51 of 107

Report No. HPLI/Test/2204003501

IS 16221 (PART 2):2015			
Clause	Requirement + Test	Result - Remark	Verdict
	The bottom of a FIRE ENCLOSURE or individual barriers, shall provide protection against emission of flaming or molten material under all internal parts, including partially enclosed components or assemblies, for which Method 2 of 9.1.1 has not been fully applied and complied with.	See above cl.no. 9.1.4.3	N/A
9.1.4.4/ RD	Equipment for use in a CLOSED ELECTRICAL OPERATING AREA	Not intend use at this area	N/A
	The requirements of 9.1.4.3 do not apply to FIXED EQUIPMENT intended only for use in a CLOSED ELECTRICAL OPERATING AREA and to be mounted on a concrete floor or other noncombustible surface. Such equipment shall be marked as follows:	See above 9.1.4.4	N/A
	WARNING: FIRE HAZARD SUITABLE FOR MOUNTING ON CONCRETE OR OTHER NONCOMBUSTIBLE SURFACE ONLY	See above 9.1.4.4	N/A
9.1.4.5/ RD	Doors or covers in fire enclosures	No any door or covers in fire enclosure.	N/A
9.1.4.6/ RD	Additional requirements for openings in transportable equipment	Not a transportable equipment	N/A
9.2/ RD	LIMITED POWER SOURCES	No limited power source used.	N/A
9.2.1/ RD	General	See above cl.no. 9.2	N/A
9.2.2/ RD	Limited power source tests	See above cl.no. 9.2	N/A
9.3	Short-circuit and overcurrent protection	See below	P
9.3.1/ RD	General	Considered	P
	The PCE shall not present a hazard, under short circuit or overcurrent conditions at any port, including phase-to-phase, phase-to-earth and phase-to-neutral, and adequate information shall be provided to allow proper selection of external wiring and external protective devices.	The short circuit and over current are protected by circuit design. When short-circuit or over current of components occurred. the EUT will shut down from grid immediately	P
9.3.2/ RD	Protection against short-circuits and over currents shall be provided for all input circuits, and for output circuits that do not comply with the requirements for limited power sources in 9.2, except for circuits in which no over current hazard is presented by short circuits and overloads.	See above cl.no. 9.3	P
9.3.3/ RD	Protective devices provided or specified shall have adequate breaking capacity to interrupt the maximum short circuit current specified for the port to which they are connected. If protection that is provided integral to the PCE for an input port is not rated for the short-circuit current of the circuit in which it is used, the installation instructions shall specify that an upstream protective device, rated for the prospective short-circuit current of that port, shall be used to provide backup protection.	See above cl.no. 9.3	P

TRF No. IS 16221 (Part 2): 2015_V1.0

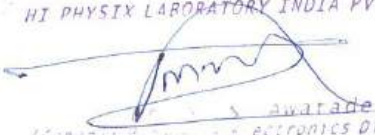
HI PHYSIX LABORATORY INDIA PVT. LTD.

 S. Awatade
 (General Manager - Electronics Division)

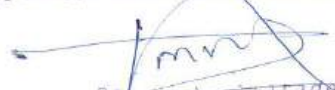

TC-5100

IS 16221 (PART 2):2015			
Clause	Requirement + Test	Result - Remark	Verdict
9.3.4	Inverter backfeed current onto the array	See below	P
	The backfeed current testing and documentation requirements in Part 1 apply, including but not limited to the following.	See below	P
	Inverter backfeed current onto the PV array maximum value.....	0A	P
	This inverter backfeed current value shall be provided in the installation instructions regardless of the value of the current, in accordance with Table 33.	Provided in user manual	P
10	Protection against sonic pressure hazards	See below	P
10.1/RD	General	See below	P
	The equipment shall provide protection against the effect of sonic pressure. Conformity tests are carried out if the equipment is likely to cause such HAZARDS.	No sonic pressure hazards.	P
10.2/ RD	Sonic pressure and Sound level	See below	P
10.2.1/ RD	Hazardous noise levels	10dB	P
11	Protection against liquid hazards	No liquid containment system used	N/A
11.1/RD	Liquid Containment, Pressure and Leakage	See above cl. no. 11	N/A
	The liquid containment system components shall be compatible with the liquid to be used.	See above cl. no. 11	N/A
	There shall be no leakage of liquid onto live parts as a result of:	See above cl. no. 11	N/A
	a) Normal operation, including condensation;	See above cl. no. 11	N/A
	b) Servicing of the equipment; or	See above cl. no. 11	N/A
	c) Inadvertent loosening or detachment of hoses or other cooling system parts over time.	See above cl. no. 11	N/A
11.2/RD	Fluid pressure and leakage	See above cl. no. 11	N/A
11.2.1/RD	Maximum pressure	See above cl. no. 11	N/A
11.2.2/RD	Leakage from parts	See above cl. no. 11	N/A
11.2.3/RD	Overpressure safety device	See above cl. no. 11	N/A
11.3/ RD	Oil and grease	See above cl. no. 11	N/A
12	Protection against Chemical Hazards	No chemical hazards	N/A
12.1/ RD	General	No chemical hazards	N/A
13	Physical requirements	See below	P
13.1/RD	Handles and manual controls	Complies	P
	Handles, knobs, grips, levers and the like shall be reliably fixed so that they will not work loose in normal use, if this might result in a hazard. Sealing compounds and the like, other than self-hardening resins, shall not be used to prevent loosening. If handles, knobs and the like are used to indicate the position of switches or similar components, it shall not be possible to fix them in a wrong position if this might result in hazard.	Complies	P

HI PHYSIX LABORATORY INDIA PVT. LTD.

 (General Manager - Electronics Division)



TC-5100

ULR-TC510022000000496F

Page 53 of 107

Report No. HPLI/Test/2204003501

IS 16221 (PART 2):2015

Clause	Requirement + Test	Result - Remark	Verdict
13.1.1/ RD	Adjustable controls	No adjustable control	N/A
13.2/RD	Securing of parts	All parts are properly secured.	P
13.3/RD	Provisions for external connections	See below	P
13.3.1/ RD	General	Complies	P
13.3.2/RD	Connection to an a.c. Mains supply	Terminal block for AC cable connection with cable gland for tightening	P
13.3.2.1/RD	General	Installation manual provide information for the disconnection means	P
	For safe and reliable connection to a MAINS supply, equipment shall be provided with one of the following:	See below	P
	– terminals or leads or a non-detachable power supply cord for permanent connection to the supply; or	Screw terminal for permanent connection to supply	P
	– a non-detachable power supply cord for connection to the supply by means of a plug	See above	N/A
	– an appliance inlet for connection of a detachable power supply cord; or	See above	N/A
	– a mains plug that is part of direct plug-in equipment as in 13.3.8	See above	N/A
13.3.2.2/ RD	Permanently connected equipment	The EUT does not provide a permanent connection in the meaning of this clause	N/A
13.3.2.3/ RD	Appliance inlets	Special industrial connector used	N/A
13.3.2.4/ RD	Power supply cord	No such supply cord used	N/A
13.3.2.5/RD	Cord anchorages and strain relief	No such supply cord used	N/A
	For equipment with a non-detachable power supply cord, a cord anchorage shall be supplied such that:	See above cl.no. 13.3.2.5	N/A
	– the connecting points of the cord conductors are relieved from strain; and	See above cl.no. 13.3.2.5	N/A
	– the outer covering of the cord is protected from abrasion.	See above cl.no. 13.3.2.5	N/A
13.3.2.6/ RD	Protection against mechanical damage	No sharp points or cutting edge at the bushing.	P
13.3.3/RD	Wiring terminals for connection of external conductors	See below	P
13.3.3.1/ RD	Wiring terminals	Complies	P
13.3.3.2/ RD	Screw terminals	No screw terminal used.	N/A

HI PHYSIX LABORATORY INDIA PVT. LTD.
M. V. Awatade
(General Manager - Electronics Division)

TRF No. IS 16221 (Part 2): 2015_V1.0



TC-5100

ULR-TC510022000000496F

Page 54 of 107

Report No. HPLI/Test/2204003501

IS 16221 (PART 2):2015

Clause	Requirement + Test	Result - Remark	Verdict
13.3.3.3/ RD	Wiring terminal sizes	Complies	P
13.3.3.4/ RD	Wiring terminal design	Not used.	N/A
13.3.3.5/ RD	Grouping of wiring terminals	Not used.	N/A
13.3.3.6/ RD	Stranded wire	Not used.	N/A
13.3.4/ RD	Supply wiring space	Complies	P
13.3.5/RD	Wire bending space for wires 10 mm ² and greater	Complies	P
13.3.6/RD	Disconnection from supply sources	Installation manual instruct the disconnect device shall be provided before connecting AC mains and PV array	P
13.3.7/RD	Connectors, plugs and sockets	The EUT provide means for special connection.	P
13.3.8/RD	Direct plug-in equipment	Not a direct plug-in equipment	N/A
13.4/RD	Internal wiring and connections	See below	P
13.4.1/RD	General	All wires were used suitably and are fixed well to prevent mechanical damaged during installation	P
13.4.2/RD	Routing	All wires were routed away from all parts which would abrade the insulation of wires	P
13.4.3/RD	Colour coding	Green/yellow wire only used for protective earthing conductor	P
13.4.4/RD	Splices and connections	All wire with core cable ends.	P
13.4.5/RD	Interconnections between parts of the PCE	Special construction of connectors to prevent from misconnection.	P
13.5/RD	Openings in enclosures	IP65 enclosure without openings	N/A
13.5.1/RD	Top and side openings	IP65 enclosure without openings	N/A

TRF No. IS 16221 (Part 2): 2015_V1.0

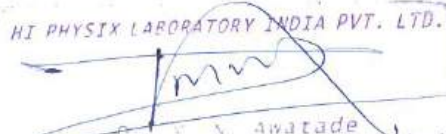
HI PHYSIX LABORATORY INDIA PVT. LTD.

V. Awatade
(General Manager - Electronics Division)



TC-5100

IS 16221 (PART 2):2015			
Clause	Requirement + Test	Result - Remark	Verdict
	Openings in the top and sides of ENCLOSURES shall be so located or constructed that it is unlikely that objects will enter the openings and create hazards by contacting bare conductive parts	See above cl.no. 13.5.1	N/A
13.6/RD	Polymeric Materials	Metal enclosure used and Certified connector, DC Switch used outside the enclosure.	P
13.6.1/RD	General	See above cl. no. 13.6	P
13.6.1.1/RD	Thermal index or capability	See above cl. no. 13.6	P
13.6.2/RD	Polymers serving as enclosures or barriers preventing access to hazards	See above cl. no. 13.6	N/A
13.6.2.1/RD	Stress relief test	See above cl. no. 13.6	P
13.6.3/RD	Polymers serving as solid insulation	See above cl. no. 13.6	P
13.6.3.1/RD	Resistance to arcing	See above cl. no. 13.6	P
13.6.4/RD	UV resistance	Certified Component used outside the enclosure	P
	Polymeric parts of an OUTDOOR ENCLOSURE required for compliance with this standard shall be sufficiently resistance to degradation by ultra-violet (UV) radiation	See above cl.no. 13.6.4	P
13.7/RD	Mechanical resistance to deflection, impact, or drop	See below	P
13.7.1/RD	General	Complies	P
13.7.2/RD	250-N deflection test for metal enclosures	No hazard	P
13.7.3/RD	7-J impact test for polymeric enclosures	No polymeric enclosure	N/A
13.7.4/RD	Drop test	Not a hand-held, direct-plug in and transportable equipment	N/A
13.8/RD	Thickness requirements for metal enclosures	Complies with 13.7	N/A
13.8.1/RD	General	See above cl.no. 13.8	N/A
13.8.2/RD	Cast metal	See above cl.no. 13.8	N/A
13.8.3/RD	Sheet metal	See above cl.no. 13.8	N/A
13.9	Fault indication	See below	P
	Where this Part 2 requires the inverter to indicate a fault, both of the following shall be provided:	Display and interface connected to PC as fault indication	P
	a) a visible or audible indication, integral to the inverter, and detectable from outside the inverter, and	EUT provides warning LEDs to read out fault messages.	P
	b) an electrical or electronic indication that can be remotely accessed and used.	EUT provides communication ports for remote access.	P
	The installation instructions shall include information regarding how to properly make connections (where applicable) and use the electrical or electronic means in b) above, in accordance with 5.3.2.10.	The instructions are specified in the manual	P

HI PHYSIX LABORATORY INDIA PVT. LTD.

 M. V. Awatade
 (General Manager - Electronics Division)



TC-5100

IS 16221 (PART 2):2015			
Clause	Requirement + Test	Result - Remark	Verdict
14	Components	See below	P
14.1/RD	General	Considered	P
	Where safety is involved, components shall be used in accordance with their specified RATINGS unless a specific exception is made. They shall conform to one of the following:	See below	P
	a) Applicable safety requirements of a relevant IEC standard. Conformity with other requirements of the component standard is not required. If necessary for the application, components shall be subjected to the test of this standard, except that it is not necessary to carry out identical or equivalent tests already performed to check conformity with the component standard;	Certified component used according to their relevant safety standards. (see list of critical components)	P
	b) the requirements of this standard and, where necessary for the application, any additional applicable safety requirements of the relevant IEC component standard;	Certified component used (see list of critical components)	P
	c) if there is no relevant IEC standard, the requirements of this standard;	Certified component used and also verified/tested according to this standard. (see list of critical component)	P
	d) applicable safety requirements of a non-IEC standard which are at least as high as those of the applicable IEC standard, provided that the component has been approved to the non-IEC standard by a recognized testing authority.	Certified component used which are harmonized to relevant IEC standards. (see list of critical components)	P
	Components such as optocouplers, capacitors, transformers, and relays connected across basic, supplemental, reinforced, or double insulation shall comply with the requirements applicable for the grade of insulation being bridged, and if not previously certified to the applicable component safety standard shall be subjected to the voltage test of 7.5.2 as routine test.	Certified component used (see list of critical components)	P
14.2/ RD	Motor Over temperature Protection	See below	P
	Motors which, when stopped or prevented from starting (see 4.4.4.3), would present an electric shock HAZARD, a temperature HAZARD, or a fire HAZARD, shall be protected by an over temperature or thermal protection device meeting the requirements of 14.3.	Power limited by temperature control in single fault condition or high temperature environment condition	P
14.3/RD	Over temperature protection devices	Impedance protected motor	P
14.4/RD	Fuse holders	No such device	N/A
14.5/RD	MAINS voltage selecting devices	See below	P
14.6/RD	Printed circuit boards	V-0 class of PCBs used	P



TC-5100

ULR-TC510022000000496F

Page 57 of 107

Report No. HPLI/Test/2204003501

IS 16221 (PART 2):2015

Clause	Requirement + Test	Result - Remark	Verdict
	Printed circuit boards shall be made of material with a flammability classification of V-1 of IEC 60707 or better	See above	P
	This requirement does not apply to thin-film flexible printed circuit boards that contain only circuits powered from limited power sources meeting the requirements of 9.2.	No such PCBs used	N/A
	Conformity of the flammability RATING is checked by inspection of data on the materials. Alternatively, conformity is checked by performing the V-1 tests specified in IEC 60707 on three samples of the relevant parts.	See cl.no. 14.6	P
14.7/RD	Circuits or components used as transient overvoltage limiting devices	Certified components used.	P
	If control of transient overvoltage is employed in the equipment, any overvoltage limiting component or circuit shall be tested with the applicable impulse withstand voltage of Table 7-10 using the test method from 7.5.1 except 10 positive and 10 negative impulses are to be applied and may be spaced up to 1 min apart.	See above	P
14.8/RD	Batteries	No battery used	N/A
	Equipment containing batteries shall be designed to reduce the risk of fire, explosion and chemical leaks under normal conditions and after a single fault in the equipment including a fault in circuitry within the equipment battery pack.	See above cl.no. 14.8	N/A
14.8.1/RD	Battery Enclosure Ventilation	See above cl.no. 14.8	N/A
14.8.1.1/RD	Ventilation requirements	See above cl.no. 14.8	N/A
14.8.1.2/RD	Ventilation testing	See above cl.no. 14.8	N/A
14.8.1.3/RD	Ventilation instructions	See above cl.no. 14.8	N/A
14.8.2/RD	Battery Mounting	See above cl.no. 14.8	N/A
	Compliance is verified by the application of the force to the battery's mounting surface. The test force is to be increased gradually so as to reach the required value in 5 to 10 s, and is to be maintained at that value for 1 min. A non-metallic rack or tray shall be tested at the highest normal condition operating temperature	See above cl.no. 14.8	N/A
14.8.3/RD	Electrolyte spillage	See above cl. no. 14.8	N/A
	Battery trays and cabinets shall have an electrolyte resistant coating.	See above cl. no. 14.8	N/A
14.8.4/RD	Battery Connections	See above cl. no. 14.8	N/A

TRF No. IS 16221 (Part 2): 2015_V1.0

HI PHYSIX LABORATORY INDIA PVT. LTD.

 (General Manager - Electronics Division)



TC-5100

IS 16221 (PART 2):2015

Clause	Requirement + Test	Result - Remark	Verdict
	Reverse battery connection of the terminals shall be prevented if reverse connection could result in a hazard within the meaning of this Standard	See above cl. no. 14.8	N/A
14.8.5/RD	Battery maintenance instructions	See above cl. no. 14.8	N/A
	The information and instructions listed in 5.3.4.1 shall be included in the operator manual for equipment in which battery maintenance is performed by the operator, or in the service manual if battery maintenance is to be performed by service personnel only.	See above cl. no. 14.8	N/A
14.8.6/RD	Battery accessibility and maintainability	See above cl. no. 14.8	N/A
	Battery terminals and connectors shall be accessible for maintenance with the correct TOOLS. Batteries with liquid electrolyte, requiring maintained shall be so located that the battery cell caps are accessible for electrolyte tests and readjusting of electrolyte levels.	See above cl. no. 14.8	N/A



TC-5100

IS 16221 (PART 2):2015						
Clause	Requirement + Test			Result - Remark		Verdict
4.2.2.6/4.7 RD	TABLE: mains supply electrical data in normal condition/ Electrical ratings tests					P
Type	U (V) DC	I (A) DC	P (kW) DC	U (V) AC	I (A) AC	P (kW) AC
KSY-22KW-3P	250	30.31	7.54	L1:207.12 L2:207.09 L3:207.15	L1:11.01 L2:11.05 L3:10.95	6.83
		30.32	7.56	L1:230.15 L2:230.32 L3:230.00	L1:10.00 L2:9.82 L3:10.56	7.25
		30.34	7.57	L1:253.00 L2:252.55 L3:252.77	L1:9.39 L2:9.77 L3:9.67	7.30
	620	38.54	23.86	L1:207.20 L2:207.16 L3:207.25	L1: 31.26 L2: 31.50 L3: 31.05	19.53
		38.56	23.88	L1:230.30 L2:230.40 L3:230.35	L1: 31.00 L2: 29.75 L3: 30.53	21.40
		38.58	23.88	L1:252.90 L2:252.85 L3:253.00	L1: 28.73 L2: 28.80 L3: 28.06	22.00
	800	28.98	23.16	L1:207.21 L2:207.37 L3:207.11	L1: 31.24 L2: 31.03 L3: 31.52	19.50
		29.00	23.18	L1:230.28 L2:230.19 L3:230.13	L1: 31.02 L2: 31.07 L3: 31.10	21.43
		29.02	23.19	L1:253.00 L2:252.70 L3:253.19	L1: 28.08 L2: 28.86 L3: 27.95	21.89

HI PHYSIX LABORATORY INDIA PVT. LTD.
(General Manager - Electronics Division)



TC-5100

IS 16221 (PART 2):2015

Clause	Requirement + Test	Result - Remark	Verdict	
4.3/RD	TABLE: Thermal Testing		P	
Type/Model:	KSY-22KW-3P		---	
Temperature t of part/at	t 1(°C): 55.0, t 2(°C): 55.6		Permitted t (°C)	
Test Condition	DC Input: 250Vdc AC Output: L1:207.06 L2:207.23 L3:207.00	DC Input: 250Vdc AC Output: L1:230.15 L2:230.24 L3:230.30	DC Input: 250Vdc AC Output: L1:252.40 L2:252.53 L3:252.86	---
Ambient (°C)	55	55	55	---
Metal Enclosure	62.6	63.2	63.7	70
PCB	68.0	68.3	68.9	130
AC output connector	66.6	68.2	68.8	90
Relay (RY1601)	69.3	69.8	70.1	85
Inductor (L503)	80.1	80.4	81.7	130
Transformer coil (TX402)	84.6	85.7	86.8	110
Transformer core (TX402)	81.1	82.2	83.1	110
X2-Capacitor (C1766)	69.2	69.4	69.7	110
Transformer coil (TX404)	87.3	87.8	88.1	110
Transformer core (TX404)	85.4	85.7	85.9	110
PV connector	64.4	64.8	66.1	85
Supplementary information: Temperature test of transformer winding is determined by thermocouple T1 is start temperature and T2 is the end of test temperature				

HI PHYSIX LABORATORY INDIA PVT. LTD.
(Signature)
A. Awatade
(General Manager - Electronics Division)



TC-5100

IS 16221 (PART 2):2015				
Clause	Requirement + Test			Verdict
4.3/RD	TABLE: Thermal Testing			P
Type/Model:	KSY-22KW-3P			---
Temperature t of part/at	t 1(°C): 55.3, t 2(°C): 55.3			Permitted t (°C)
Test Condition	DC Input: 620Vdc AC Output: L1:207.11 L2:207.17 L3:207.05	DC Input: 620Vdc AC Output: L1:230.13 L2:230.25 L3:230.15	DC Input: 620Vdc AC Output: L1:252.24 L2:252.59 L3:252.45	---
Ambient (°C)	55	55	55	----
Metal Enclosure	62.8	63.5	63.9	70
PCB	68.5	68.7	69.1	130
AC output connector	65.8	67.9	69.2	90
Relay (RY1601)	69.5	70.1	70.3	85
Inductor (L503)	80.3	80.7	81.9	130
Transformer coil (TX402)	84.8	85.9	87.1	110
Transformer core (TX402)	81.4	82.5	83.3	110
X2-Capacitor (C1766)	69.4	69.6	69.9	110
Transformer coil (TX404)	85.7	85.9	88.1	110
Transformer core (TX404)	82.3	82.8	83.3	110
PV connector	65.1	66.7	67.9	85
Supplementary information: Temperature test of transformer winding is determined by thermocouple T1 is start temperature and T2 is the end of test temperature				

HI PHYSIX LABORATORY INDIA PVT. LTD.
[Signature]
Awatade
(Head of Dept. - Electronics Division)



TC-5100

IS 16221 (PART 2):2015				
Clause	Requirement + Test			Verdict
4.3/RD	TABLE: Thermal Testing			P
Type/Model:	KSY-22KW-3P			---
Temperature t of part/at	t 1(°C): 55.4, t 2(°C): 55.2			Permitted t (°C)
Test Condition	DC Input: 800Vdc AC Output: L1:207.17 L2:207.31 L3:207.19	DC Input: 800Vdc AC Output: L1:230.16 L2:230.50 L3:230.28	DC Input: 800Vdc AC Output: L1:252.30 L2:253.00 L3:252.40	---
Ambient (°C)	55	55	55	---
Metal Enclosure	62.5	64.0	64.2	70
PCB	68.7	68.9	69.4	130
AC output connector	65.9	68.1	69.3	90
Relay (RY1601)	70.1	70.3	70.7	85
Inductor (L503)	80.8	80.9	83.0	130
Transformer coil (TX402)	85.1	86.2	87.3	110
Transformer core (TX402)	81.6	82.8	83.7	110
X2-Capacitor (C1766)	70.0	70.3	70.5	110
Transformer coil (TX404)	85.4	85.7	85.9	110
Transformer core (TX404)	83.0	84.4	84.4	110
PV connector	68.2	68.7	68.8	85
Supplementary information: Temperature test of transformer winding is determined by thermocouple T1 is start temperature and T2 is the end of test temperature				

HI PHYSIX LABORATORY INDIA PVT. LTD.
(General Manager - Electronics Division)



TC-5100

IS 16221 (PART 2):2015

Clause	Requirement + Test	Result - Remark	Verdict			
4.4.4	TABLE: Single fault condition to be applied		P			
	Ambient temperature (°C):	25°C	—			
	Power source for EUT: Manufacturer, model/type, output rating..... :	Ksolare Energy Private Limited KSY-22KW-3P, 22000W	—			
4.4.4.15.1	Fault-tolerance of residual current monitoring					
Component No.	Fault	Supply voltage (V)	Test time	Fuse #	Fuse current (A)	Observation
Output L1-L2 L2-L3 L3-L1	Mismatch before start-up	PV input :620Vdc AC output: L1:252.75 L2:253.00 L3:252.47	10min	---	---	Unit doesn't connect to grid at different mismatch connection, Error message display on the screen No damage, no hazard, no fire.
Output L2-L3	Short circuited	PV input: 620Vdc AC output: L1:252.44 L2:253.00 L3:252.42	10min	---	---	Inverter cut off Immediately after short- circuit, Error message display on the screen No damage, no hazard, no fire.
Output L1-L3	Short circuited	PV input: 620Vdc AC output: L1:253.00 L2:253.01 L3:252.19	10min	---	---	Inverter cut off Immediately after short- circuit, Error message display on the screen No damage, no hazard, no fire.
Output L1-L2	Short circuited	PV input: 620Vdc AC output: L1:252.50 L2:252.27 L3:252.30	10min	---	---	Inverter cut off Immediately after short- circuit, Error message display on the screen No damage, no hazard, no fire.
Output	Overload	PVinput:620Vdc AC output: L1:230.00 L2:230.19 L3:230.26	30min	---	---	Unit works in fault mode, Error message display on the screen No damage, no hazard, no fire. No excessive temperature rise was measured.

HI PHYSIX LABORATORY INDIA PVT. LTD.
(Signature)
Anarade
(General Manager - Electronics Division)



TC-5100

ULR-TC510022000000496F

Page 64 of 107

Report No. HPLI/Test/2204003501

IS 16221 (PART 2):2015

Clause	Requirement + Test	Result - Remark	Verdict
Fan	Blocked during operation PV input :620Vdc 7h AC output: L1:252.13 L2:252.10 L3:252.77	---	Unit start derating of the power output No damage, no hazard, no fire.
Fan	Blocked before start PV input :620Vdc 7h AC output: L1:252.00 L2:253.00 L3:252.40	---	Unit start derating of the power output No damage, no hazard, no fire.
Relay	Contact Short circuited before startup inverter PV input :620Vdc 5 min AC output: L1:251.60 L2:252.43 L3:252.05	---	Error message display on the screen Unit does not start-up, the inverter did not connect to the grid. No damage, no hazard, no fire.
DC+ to DC-	Short-circuited PV input :620Vdc 10 min AC output: L1:252.26 L2:252.20 L3:252.22	---	Error message display on the screen Inverter cannot start up.No output no power feed into grid. No damage, no hazard, no fire
Transformer	Short-circuited PV input :620Vdc 10min AC output: L1:252.45 L2:252.14 L3:252.27	---	Error message display on the screen. Unit shut down, No damage, no hazard, no fire
Printed wiring board	Short-circuited PV input :620Vdc 10 min AC output: L1:252.53 L2:252.47 L3:252.41	---	Inverter cut off Immediately after short- circuit, Error message display on the screen No damage, no hazard, no fire.
Check that the residual current monitoring operates properly			Yes
Supplementary information: Nil			

TRF No. IS 16221 (Part 2): 2015_V1.0

HI PHYSIX LABORATORY INDIA PVT. LTD.
(Signature)
Awatade
(General Manager - Electronics Division)



TC-5100

IS 16221 (PART 2):2015

Clause	Requirement + Test	Result - Remark	Verdict	
4.4.4.17	Cooling system failure – Blanketing test		P	
	Test voltage (Vdc).....:	620	800	---
	Test current (Idc)	38.53	29.00	---
	Test voltage (Vac).....:	L1:252.89 L2:252.55 L3:252.98	L1:252.41 L2:252.16 L3:252.78	---
	Test current (Iac)-----:	L1:30.77 L2:30.96 L3:30.74	L1:28.59 L2:28.84 L3:28.37	---
	t _{amb1} (°C):	55	55	---
	t _{amb2} (°C):	55	55	---
	maximum temperature T of part/at::	T (°C)		T_{max} (°C)
	Enclosure top	64.0	64.5	90
	Enclosure Left	66.2	66.8	90
	Enclosure Right	65.3	67.7	90
	Enclosure bottom	66.6	67.9	90
Supplementary information: Nil				

4.7.4	TABLE: Steady state Inverter AC output voltage and frequency		N/A
	Nominal DC input (V)		---
	Nominal output AC voltage (V) :		---
AC output U (V)	Frequency (Hz)	Condition/status	Comments
---	---	Without load	---
---	---	Resistive load application	---
---	---	Resistive load removal	---
Supplementary information: The PCE is not a standalone unit; therefore, the Steady State Inverter AC output voltage and frequency is not deemed applicable.			

HI PHYSIX LABORATORY INDIA PVT. LTD.
(General Manager - Electronics Division)



TC-5100

IS 16221 (PART 2):2015			
Clause	Requirement + Test	Result - Remark	Verdict

4.8.2	TABLE: Array insulation resistance detection for inverters for ungrounded and functionally grounded arrays		P
-------	--	--	---

4.8.2.1	Array insulation resistance detection for inverters for ungrounded arrays		P
---------	---	--	---

DC Voltage below minimum operating voltage (V)	DC Voltage for inverter begin operation (V)	Resistance between ground and PV input terminal (kΩ)	Required Insulation resistance $R = (V_{MAX PV} / 30mA)$ (kΩ)	Result
DC+				
200	250	29.99	33.33	Unit can't start up, Error message on display Isolation fault
200	620	29.99	33.33	Unit can't start up, Error message on display Isolation fault
200	800	29.99	33.33	Unit can't start up, Error message on display Isolation fault
DC-				
200	250	29.99	33.33	Unit can't start up, Error message on display Isolation fault
200	620	29.99	33.33	Unit can't start up, Error message on display Isolation fault
200	800	29.99	33.33	Unit can't start up, Error message on display Isolation fault

Note:

For isolated inverters, shall indicate a fault in accordance with 13.9 (operation is allowed); the fault indication shall be maintained until the array insulation resistance has recovered to a value higher than the limit above

For non-isolated inverters, or inverters with isolation not complying with the leakage current limits in the minimum inverter isolation requirements in Table 30, shall indicate a fault in accordance with 13.9, and shall not connect to the mains; the inverter may continue to make the measurement, may stop indicating a fault and may connect to the mains if the array insulation resistance has recovered to a value higher than the limit above.

It is not required to test all PV input terminals if analysis of the design indicates that one or more terminals can be expected to have the same result, for example where multiple PV string inputs are in parallel.

Supplementary information: Nil

HI PHYSIX LABORATORY INDIA PVT. LTD.

(Handwritten signature)
Awatade
(General Manager - Electronics Division)



TC-5100

IS 16221 (PART 2):2015

Clause	Requirement + Test	Result - Remark	Verdict
--------	--------------------	-----------------	---------

4.8.3.2	TABLE: 30mA touch current type test for isolated inverters		N/A
	Condition	Current (mA)	Limit (30mA)
	DC+ to PE	---	---
	DC- to PE	---	---

Supplementary information:

- The touch current measurement circuit of IEC 60990, Figure 4 is connected from each terminal of the array to ground, one at a time.

4.8.3.3	TABLE: Fire hazard residual current type test for isolated inverters		N/A
	Condition	Current (mA)	Limit (300mA or 10mA per kVA)
	DC+ to PE	---	---
	DC- to PE	---	---

Supplementary information:

HI PHYSIX LABORATORY INDIA PVT. LTD.

 D. V. Awatade
 (General Manager - Electronics Division)



TC-5100

IS 16221 (PART 2):2015

Clause	Requirement + Test	Result - Remark	Verdict
--------	--------------------	-----------------	---------

4.8.3.5	TABLE: Protection by residual current monitoring		P
---------	--	--	---

Test conditions:	Output power (W):22000 Input voltage (V _{DC}):620 Frequency (Hz): 50 Output AC Voltage (VAC): L1:230.13, L2:230.04, L3:230.08
------------------	--

4.8.3.5.2	Test for detection of excessive continuous residual current		P
-----------	---	--	---

Fault Current (mA)		Disconnection time (ms)	
Measured Fault Current	Limit 300mA for output power ≤30 kVA 10mA per kVA for output power > 30 kVA	Measured Disconnection time	Limit
+ PV to N:			
65	300	158	300
63	300	160	300
60	300	163	300
61	300	165	300
67	300	170	300
- PV to N:			
65	300	155	300
63	300	158	300
60	300	156	300
61	300	159	300
67	300	156	300

Note:

- maximum 300mA for inverters with continuous output power rating ≤30kVA;
- maximum 10mA per kVA of rated continuous output power for inverters with continuous output power rating > 30kVA.

This test shall be repeated 5 times, and for all 5 tests the time to disconnect shall not exceed 0.3s. The test is repeated for each PV input terminal. It is not required to test all PV input terminals if analysis of the design indicates that one or more terminals can be expected to have the same result, for example where multiple PV string inputs are in parallel.

Supplementary information: Nil

HI PHYSIX LABORATORY INDIA PVT. LTD.
(General Manager - Electronics Division)



TC-5100

IS 16221 (PART 2):2015			
Clause	Requirement + Test	Result - Remark	Verdict
4.8.3.5.3	TABLE: Test for detection of sudden changes in residual current		P
+PV to N			
Limit (mA)	U_N		Limit (ms)
	Disconnection time (ms)		
30	135		300
30	133		300
30	130		300
30	136		300
30	140		300
60	88		150
60	90		150
60	86		150
60	89		150
60	92		150
150	18		40
150	21		40
150	23		40
150	22		40
150	24		40
-PV to N			
Limit (mA)	U_N		Limit (ms)
	Disconnection time (ms)		
30	133		300
30	136		300
30	128		300
30	138		300
30	137		300
60	92		150
60	87		150
60	93		150
60	86		150
60	90		150



TC-5100

IS 16221 (PART 2):2015

Clause	Requirement + Test	Result - Remark	Verdict
150	20		40
150	19		40
150	25		40
150	17		40
150	26		40

Note: The capacitive current is risen until disconnection.

Test condition: $I_c + 30/60/150mA \leq I_{cmax}$. R_1 is set that 30/60/150mA Flow and switch S is closed.

Supplementary information: Nil

7.3.6.3.3/RD TABLE: Protective equipotential bonding				P
Measured between	Test Current (A)	Voltage drop (V)	Resistance (mΩ)	Result
Earth terminal to enclosure metal screw	64	0.57	8.91	No melting, No loosening, No damage

Supplementary information: Nil

7.3.6.3.7/RD TABLE: Touch current measurement				P
External protective earthing terminal and earthing terminal of PCE	1.95	3.5	---	

Supplementary information: Nil

7.3.7/RD TABLE: Clearance and creepage measurements							P
Measured between	Up (V)	U r.m.s (V)	Required cl (mm)	cl (mm)	Required cr (mm)	Cr (mm)	
Line (U) to N (FI)	326	230	3.0	4.17	3.0	4.17	
AC circuit (W) to ground (BI)	326	230	3.0	5.43	3.0	5.43	
Mains circuit to SELV circuit (RI)	326	230	5.5	7.75	5.5	7.75	
PV circuit to ground (BI)	1000	---	3.0	5.43	3.0	5.43	
PV2+ to PV2-(FI)	1000	---	3.0	5.93	3.0	5.93	

Supplementary information:
FI: Functional insulation, BI: Basic insulation, RI: Reinforced insulation

HI PHYSIX LABORATORY INDIA PVT. LTD.
(Signature)
Anatade
Electronics Division



TC-5100

ULR-TC510022000000496F

Page 71 of 107

Report No. HPLI/Test/2204003501

IS 16221 (PART 2):2015

Clause	Requirement + Test	Result - Remark	Verdict
--------	--------------------	-----------------	---------

7.3.7/RD	TABLE: Distance through insulation measurement				P
Distance through insulation	U r.m.s (V)	Test volatge (V)	Required di (mm)	Di (mm)	
Transformer insulation tape (TX402)	230	3000	0.2	>0.2	
Supplementary information: Nil					

7.5/RD	TABLE: electric strength measurements, impulse voltage test and partial discharge test				P
Test voltage applied between	Test volatge (V)	Impulse withstand voltage (V)	Partial discharge voltage (V)	Results	
PV input terminal to ground (BI)	1500	4000	---	Pass	
AC output to ground (BI)	1500	4000	---	Pass	
PV input terminal to communication port (RI)	3000	6000	---	Pass	
AC output terminal to communication port (RI)	3000	6000	---	Pass	
Supplementary information: BI: Basic insulation, RI: Reinforced insulation					

9.2/RD	TABLE: Limited power sources			N/A
Circuit output tested				
Components	Uoc (V)	Isc (A)		VA
		Meas.	Limit	
---	---	---	---	---
Supplementary information:				

HI PHYSIX LABORATORY INDIA PVT. LTD.

(General Manager - Electronics Division)

TRF No. IS 16221 (Part 2): 2015_V1.0



TC-5100

IS 16221 (PART 2):2015

Clause	Requirement + Test	Result - Remark	Verdict
--------	--------------------	-----------------	---------

Appendix A

USER MANUAL

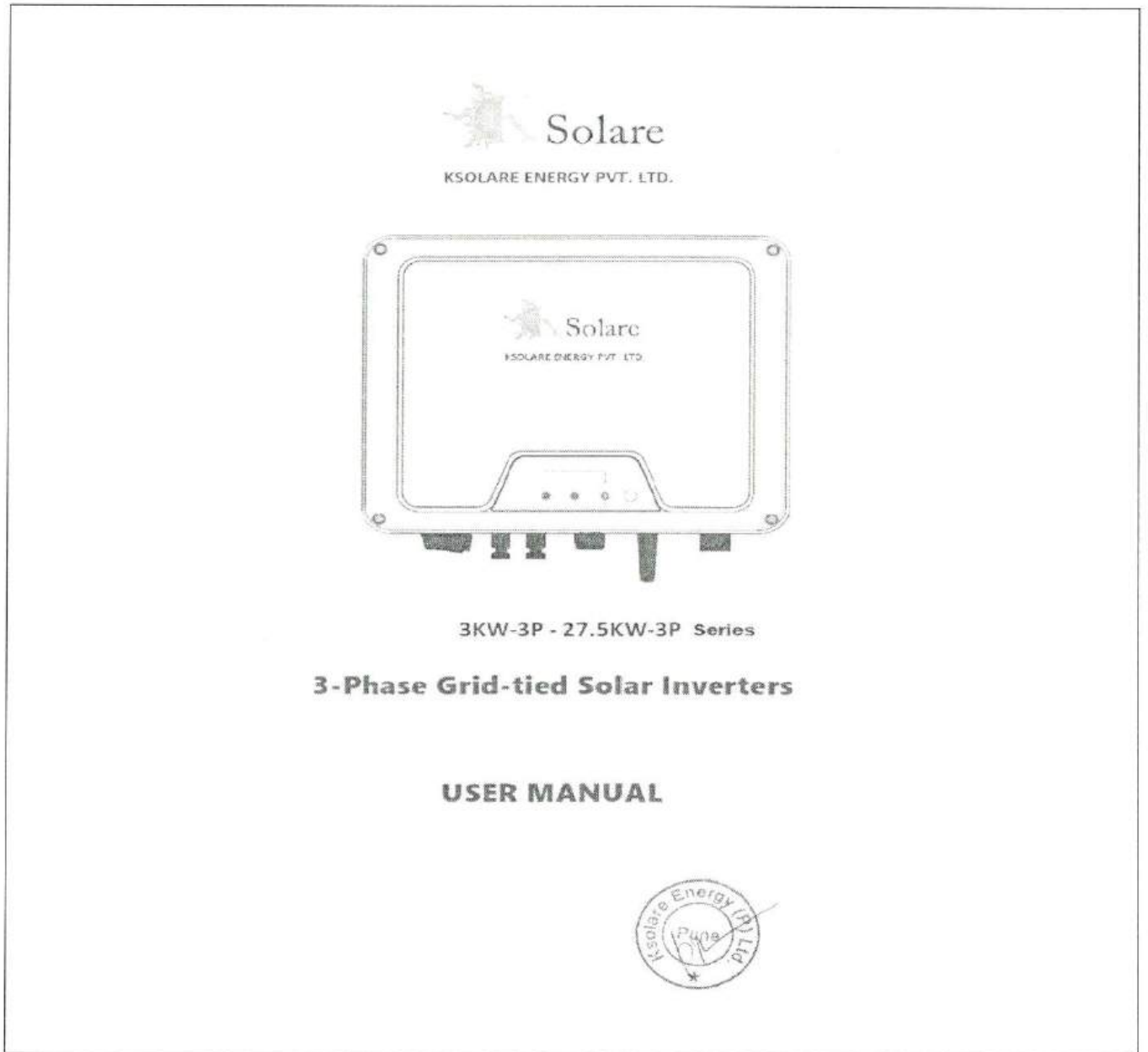



TC-5100

IS 16221 (PART 2):2015

Clause	Requirement + Test	Result - Remark	Verdict
--------	--------------------	-----------------	---------

1. SYMBOLS ON THE LABEL

	DANGER, WARNING AND CAUTION		RECYCLABLE AND REUSABLE
	HIGH VOLTAGE AVOID CONTACT		AVOID DAMP AND MOISTURE
	HIGH TEMPERATURE AVOID CONTACT		SHIPMENT STACK LIMIT: 7
	CE MARKS		DO NOT DISPOSE WITH HOUSEHOLD WASTE
	PROCEED OPERATIONS AFTER 5 MINUTES DISCHARGE		BREAKABLE ITEM
	PLACE UPWARDS		USER MANUAL IN PACK

2. SAFETY AND WARNINGS

- All persons who are responsible for mounting, installation, commissioning, maintenance, tests, and service of K SOLARE inverter products must be suitably trained and qualified for corresponding operations. They MUST be experienced and have knowledge of operation safety and professional methods. All installation personnel must have knowledge of all applicable safety information, standards, directives, and regulations.
- The product must ONLY be connected and operated with PV arrays of protection class II, in accordance with IEC 61730, application class A. The PV modules must also

5 USER MANUAL

HI PHYSIX LABORATORY INDIA PVT. LTD.

(Handwritten signature)
M. V. Awatade
(General Manager - Electronics Division)



TC-5100

IS 16221 (PART 2):2015

Clause	Requirement + Test	Result - Remark	Verdict
--------	--------------------	-----------------	---------

- be compatible with this product. Power resources other than compatible PV arrays MUST not be connected and operate with the product.
- When designing or constructing a PV system, all components MUST remain in their permitted operating ranges, and their installation requirements MUST always be fulfilled.
 - Under exposure to sunlight, the PV array may generate dangerous output in DC voltage. Contacts with the DC wires, conductors and live components in the inverter may result in lethal shocks.
 - High voltages in inverter could cause lethal electrical shocks. Before proceeding any work, including maintenance and/or service, on the inverter, fully disconnect it from all DC input, AC grid and other voltage sources. There MUST be a 5-minute waiting time after the full disconnection.
 - The DC input voltage of the PV array MUST never exceed the maximum input voltage of the inverter.
 - DO NOT touch parts of the inverter during operation as heat will be induced and these parts will exceed 60°C.

3. UNPACKING

3.1 Scope of Delivery

Please inspect and check for completeness in the scope of delivery. Confirm with purchase order.

INVERTER	MOUNTING BRACKET	MOUNTING ACCESSORIES	DC PLUGS (wired)	AC CONNECTOR	COM DATALOGGER (OPTIONAL)	METER/DRED CONNECTOR	DOCUMENTS
1	1	1	34	1	1		1

3.2 Product Overview

The total size of inverter is 425(width) × 351(height) × 200(depth) mm. It has 4 pairs of PV input terminals and 2 communication ports. It also has a LED&LCD (or just LED, determined by user) for getting information and setting parameters at field.

USER MANUAL 6

HI PHYSIX LABORATORY INDIA PVT. LTD.

(General Manager - Electronics Division)



TC-5100

IS 16221 (PART 2):2015

Clause	Requirement + Test	Result - Remark	Verdict
--------	--------------------	-----------------	---------

The detail description is shown below:

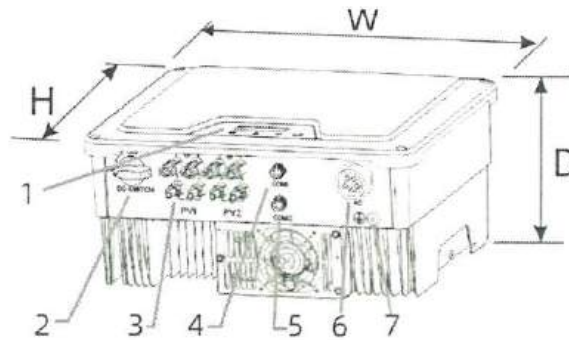

Mark Num.	Component	Description
1	LED&LCD or LED	Display and setting device at field
2	DC Switch	For switch on/off the inverter
3	PV Terminal (s)	Connected with PV Panel
4	COM1. Wi-Fi/GPRS/RS485	Alternative distant communication method
5	COM2. METER/DRED	For smart-meter or DRED
6	Secondary PE Terminal	For Grounding Protection
7	AC Terminal	Connected with AC Grid



TC-5100

IS 16221 (PART 2):2015

Clause	Requirement + Test	Result - Remark	Verdict
--------	--------------------	-----------------	---------

4. INSTALLING

4.1 Installation Requirement

1. Please install the inverter(s) in places that can avoid inadvertent contact.
2. Installation method, location and surface must be fitting for the inverter's weight and dimensions.
3. Please install the inverter in an accessible location for operation, future maintenance and service.
4. The inverter performance peaks at ambient temperature lower than 45°C.
5. When installing in residential or domestic environment, it is recommended to install and mount the inverter on a solid, concrete wall surface. Mounting the inverter on composite or plaster boards or walls with similar materials would induce noise during its operation and is therefore not recommended.
6. DO NOT cover the inverter NOR place any objects on top of the inverter.
7. To ensure sufficient room for heat dissipation and maintenance, the clearing space between inverter(s) and other surroundings is indicated below for reference.

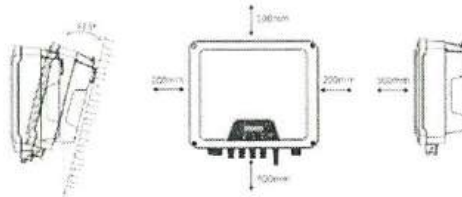

8. Avoid direct exposure to sunlight and rain and snow layup.

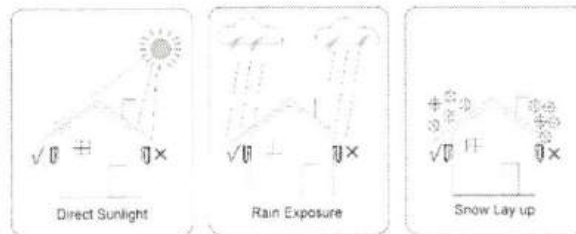

USER MANUAL 8

HI PHYSIX LABORATORY INDIA PVT. LTD.
[Signature]
 Anirudh
 (General Manager - Electronics Division)



TC-5100

IS 16221 (PART 2):2015

Clause	Requirement + Test	Result - Remark	Verdict
--------	--------------------	-----------------	---------

4.2 Mounting Location

1. DO NOT mount the inverter near any inflammable materials.
2. DO NOT mount the inverter near any explosive materials.

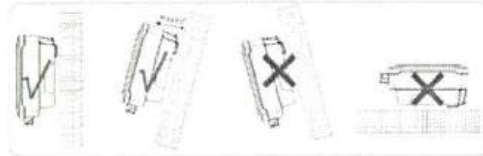

3. DO NOT mount the inverter on tilting surface over 15° backwards. Please mount the inverter on a vertical wall surface.
4. DO NOT mount the inverter on any surfaces tilting forward or to either sides.
5. DO NOT mount the inverter on a horizontal surface.
6. For easy installation and operation, please mount the inverter on a height that the display could match eye level.
7. The bottom side where all commissioning terminals are equipped MUST always point downwards.

HI PHYSIX LABORATORY INDIA PVT. LTD.

 M. S. Swatada
 (General Manager - Electronics Division)



TC-5100

IS 16221 (PART 2):2015

Clause	Requirement + Test	Result - Remark	Verdict
--------	--------------------	-----------------	---------

4.3 Mounting

1. Use the mounting bracket as a template and drill holes of 10mm diameter and 70mm depth.
2. Fix the mounting bracket with the screws and expansion bolts packed in mounting accessories.
3. Hold up the inverter and tilt it slightly forward. Hang up the inverter and attach it to the mounting bracket. Check both sides of the heat sink to ensure its stably attached.
4. Use M5 screws (T25 screwdriver, torque 2.5 Nm) to attach the heat sink fins to the mounting bracket.
5. It is recommended to attach the anti-theft lock to the inverter. Lock diameter: $\phi 4-5.5\text{mm}$ recommended.

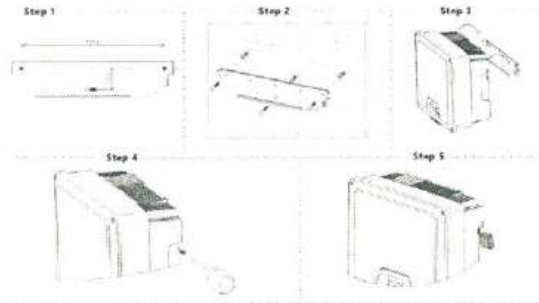

4.4 Installing the PE cable

1. Insert the grounding conductor into the suitable terminal lug and crimp the contact.
2. Align the terminal lug with the grounding conductor and the ground washer on the screw. The teeth of the ground washer must be facing the housing.
3. Tighten it firmly into the housing (screwdriver type: T25, torque: 2.5Nm).

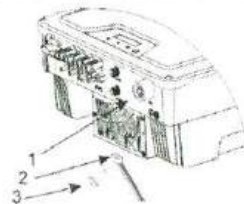

USER MANUAL 10



TC-5100

IS 16221 (PART 2):2015

Clause	Requirement + Test	Result - Remark	Verdict
--------	--------------------	-----------------	---------

Information on grounding components:

Object	Description
1	Housing
2	M5 terminal lug with protective conductor
3	M6×12 pan head screw

PE Conductor cross-section: 16 mm²

5. COMMISSIONING

5.1 Safety Instructions

1. Measure the frequency and voltage of grid connection and make sure they follow the inverter's grid connection specifications.
2. An external circuit-breaker on the AC side (or a fuse) at 1.25•AC rated current is strongly recommended.
3. Reliability of all earth connections must be tested and valid.
4. Before commissioning, disconnect the inverter and the circuit-breaker or fuse, and prevent accidental reconnection.

HI PHYSIX LABORATORY INDIA PVT. LTD.

(Handwritten signature)
Awatade
(General Manager - Electronics Division)



TC-5100

IS 16221 (PART 2):2015

Clause	Requirement + Test	Result - Remark	Verdict
--------	--------------------	-----------------	---------

5.2 AC Wire Assembly and Connection

5.2.1 AC Commissioning

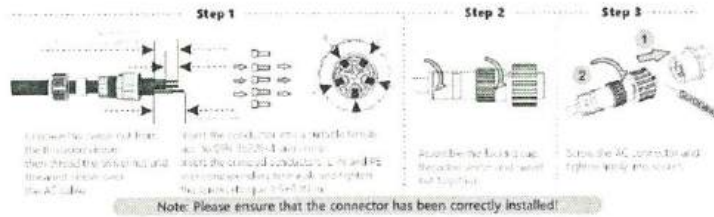

USER MANUAL 12

HI PHYSIX LABORATORY INDIA PVT. LTD.

[Handwritten Signature]
 S. Awatade
 (General Manager - Electronics Division)



TC-5100

IS 16221 (PART 2):2015

Clause	Requirement + Test	Result - Remark	Verdict
--------	--------------------	-----------------	---------

5.3 DC Wire Assembly and Connection

1. PV modules of the connected strings must be of the same time, identical alignment and tilting angle.
2. Before commissioning and connecting the PV arrays, the DC switch MUST be open.
3. Parallel strings must have the same number of modules.
4. It is mandatory to use the DC connectors within package for the connection of PV arrays.
5. The polarity of the PV arrays MUST be compatible to the DC connectors of the inverter.
6. The DC input voltage AND DC input current of the PV array MUST never exceed the maximum input allowance of the inverter.

DC Commissioning:

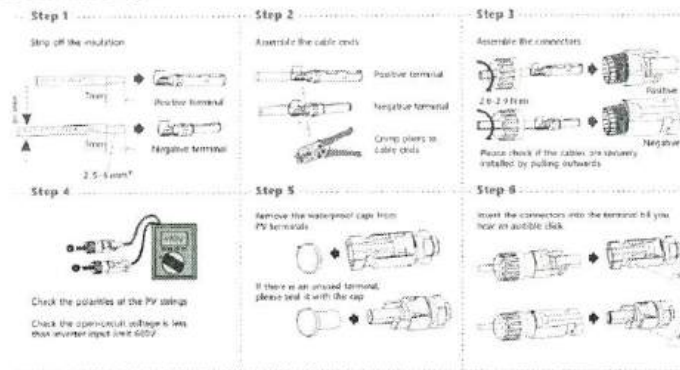

5.4 Residual Current Protection

This product is equipped with residual current protection device internally, in accordance with IEC 60364-7-714. An external residual current protection device is not needed. If the local regulation demands otherwise, it is recommended to install a 30mA Type B residual current protection device.

HI PHYSIX LABORATORY INDIA PVT. LTD.
(General Manager - Electronics Division)



TC-5100

IS 16221 (PART 2):2015

Clause	Requirement + Test	Result - Remark	Verdict
--------	--------------------	-----------------	---------

6. COMMUNICATION

6.1 System monitoring via Datalogger - RS485/Wi-Fi /GPRS (Optional)

6.1.1 Wi-Fi/GPRS Datalogger installation

1. Unpack the Datalogger from package.
2. Unscrew the cap in COM1 port and plug the Datalogger in and tighten.
3. For user guidance and configuration of Datalogger, please refer to the

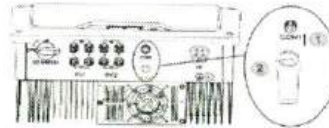

corresponding **KSOLARE** Wi-Fi Stick Guide manual, which is available in printed form inside Documents pack, or an online manual on **KSOLARE** website at <https://www.ksolare.com>

6.1.2 RS485/Smart Meter/DRED Connection

Position

Step 1

Insert the wires into suitable ferrules (DIN 402 CB) and crimp.

Step 2

Insert the crimped conductors accordingly into their corresponding terminals and tighten the screws use the screwdriver in the attached bag.

THREE CORE CABLE	WIRE TO BE CALLED FOR CABLE
POWER + → PIN 1	RS485 B → PIN 1
POWER - → PIN 2	RS485 A → PIN 2
RS485 A → PIN 3	COM LOAD/0 → PIN 3
RS485 B → PIN 4	REF GEN/0 → PIN 4

Step 3

Assemble the locking cap, threaded screw and washer nut together.

Step 4

Screw the connector into the socket and tighten firmly.

USER MANUAL 14

HI PHYSIX LABORATORY INDIA PVT. LTD.

(Signature)
A. Awatade
(Quality Control - Electronics Division)



TC-5100

IS 16221 (PART 2):2015

Clause	Requirement + Test	Result - Remark	Verdict
--------	--------------------	-----------------	---------



When installing RS485, the COM sealing plate needs to be removed. All operation **MUST NOT** proceed until AC and DC power is securely disconnected and discharged to prevent electric shocks.

6.2 Output Power Control via Smart Meter

The inverter's active power output and efficiency could be monitored via the application of a smart meter.



Please refer to **EASTRON SDM630- Modbus V2 User manual** for its connection and baud rate settings.

6.3 Demand Responsive Modes (DRMs)



DRMs Application Description

- Only applicable to AS/NZS4777.2:2015.
- Only DRM0 is available.

Users can close the S9 on DREDBOX to activate DRED function and Operate the Disconnection Device by close S0. Other function of DRED is all disabled.

The inverter shall detect and initiate a response to all supported demand response commands.

Moistures and Dust will damage the inverter

- Secure and tighten the screws on COM sealing plate.
- Warranty will be void if the inverter is damaged due to moisture and dust caused by poor installation of COM sealing plate.

HI PHYSIX LABORATORY INDIA PVT. LTD.

 (General Manager - Electronics Division)



TC-5100

IS 16221 (PART 2):2015

Clause	Requirement + Test	Result - Remark	Verdict
--------	--------------------	-----------------	---------

7. START UP AND OPERATION

7.1 Safety Check Before Start Up

Please check before switching on any voltage resources connected to the inverter and closing inverter's DC switch:

1. Grid Voltage: Check the grid voltage at point of connection at the inverter complies with permitted range of the inverter.
2. Mounting Bracket: Check if the mounting bracket is properly and securely installed.
3. Mounting of the inverter: Check if the inverter is properly mounted and attached to the mounting bracket.
4. DC Connectors: Check if the DC connectors are installed correctly on terminals.
5. AC Connectors and Wire Assembly: Check if wires are assembled correctly on the AC side and if the AC connector is properly and securely installed. Check if the AC connector is firmly plugged into AC terminal.
6. Cables: Check if all cables are reliably connected. Check if the connections are effective, while the insulations are undamaged.
7. Groundings: Check all groundings using multimeter and if all exposed metal parts of the inverter are properly grounded.
8. DC Voltage: Check if the largest open-circuit voltage of PV arrays complies with the permitted range.
9. DC Polarity: Check if the wires from DC voltage resource are connected to terminals with correct polarity.
10. Grounding Resistance: Check if the grounding resistance of PV strings >1MΩhm using a multimeter.

After all installation and checks, close the AC circuit-breaker, then the DC switch. The inverter will start to operate when DC input voltage and grid conditions meet the requirements of inverter startup.

USER MANUAL 16

HI PHYSIX LABORATORY INDIA PVT. LTD.

 Dr. V. A. Awatade
 (General Manager - Electronics Division)





TC-5100

IS 16221 (PART 2):2015

Clause	Requirement + Test	Result - Remark	Verdict
--------	--------------------	-----------------	---------

7.2 Inverter LED Indicators

When the inverter operates, LED symbols on display have the following meanings.

 POWER	<ul style="list-style-type: none"> <input checked="" type="radio"/> ON Inverter Power ON and Feeding Power to Load <input checked="" type="radio"/> Blink Inverter Power ON, Not Feeding Power to Load <input type="radio"/> OFF Inverter Power OFF, DC Disconnected
 FAULT	<ul style="list-style-type: none"> <input checked="" type="radio"/> ON Inverter is faulty <input type="radio"/> OFF No Fault
 COM	<ul style="list-style-type: none"> <input checked="" type="radio"/> Blink Communication Device Connected <input type="radio"/> OFF Communication Device Disconnected

HI PHYSIX LABORATORY INDIA PVT. LTD.

 M. V. Awatade
 (General Manager - Electronics Division)



TC-5100

IS 16221 (PART 2):2015

Clause	Requirement + Test	Result - Remark	Verdict
--------	--------------------	-----------------	---------

7.3 Display and Control Logics

When inverter starts up and operates, there is a control button beside LCD Display of the inverter. Please follow the logics listed below.

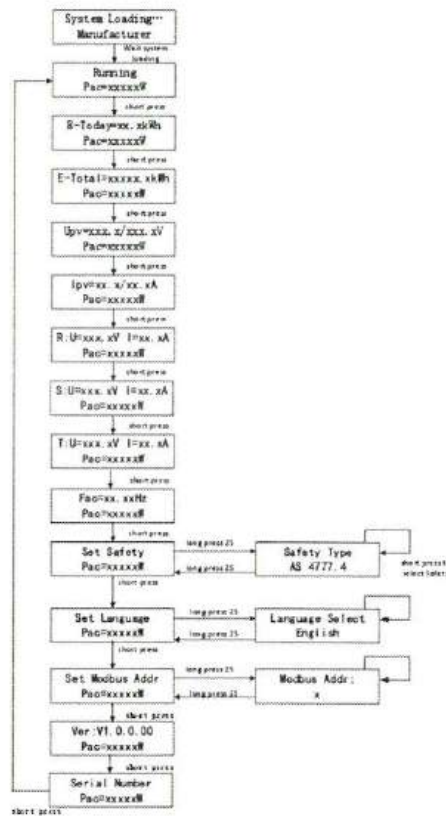

USER MANUAL 18

HI PHYSIX LABORATORY INDIA PVT. LTD.
[Signature]
Swarade
(General Manager - Electronics Division)



TC-5100

IS 16221 (PART 2):2015

Clause	Requirement + Test	Result - Remark	Verdict
--------	--------------------	-----------------	---------

8. DISCONNECTING FROM VOLTAGE RESOURCES

Before proceeding any operations on inverter, please disconnect the inverter from all voltage resources as described in this manual.

Following these steps in described sequence are mandatory.

1. Disconnect miniature circuit-breaker and prevent from unintentional reconnections.
2. Open the DC switch and prevent the switch from closing unintentionally.
3. Use clamps to ensure there is no electrical current in DC wires.
4. Disconnect all DC connections and resources. Unplug the DC connectors, and DO NOT pull the cables.

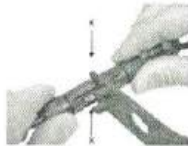

5. Use multimeter to ensure the voltage on DC terminals of inverter is 0.
6. Unscrew and remove the AC connector.

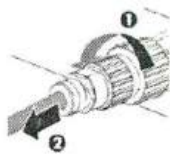

 **Danger to life due to high voltages.**
 Inverter capacitors need 10 minutes to be completely de-energized.
 When an error occurs, DO NOT remove the cover of the inverter onsite. Improper operations and attempts may induce electric shock.

HI PHYSIX LABORATORY INDIA PVT. LTD.

(Signature)
General Manager - Electronics Division



TC-5100

IS 16221 (PART 2):2015

Clause	Requirement + Test	Result - Remark	Verdict
--------	--------------------	-----------------	---------

10. TROUBLE SHOOTING

Earth Fault Alarm

This inverter complies with IEC 62109-2 clause 13.9 for earth fault alarm monitoring. If an **Earth Fault Alarm** occurs, the **error code 6** will be displayed on the LCD. Red LED indicator will also light up.

If an external indication of earth fault alarm is required, please connect PV System to inverter monitoring app/portal. The monitoring platform will send email notification in the event of an Earth Fault. Please refer to Sector 6.1 and KSOLARE WI-FI STICK GUIDE on how to setup your inverter communication function.

Full Error Code and Corrective Measures

When the PV system does not operate normally, we recommend the following solutions for quick troubleshooting. If an error occurs, the Error code will be displayed on the inverter's screen or on the KSOLARE's monitoring App/Web, the red LED will light up. The corresponding corrective measures are as follows.

Error Code	Fault Name	Description	Corrective Measures
1	Functional fault in Micro-Controller Unit (MCU)	MCU abnormal self-check in start process	Disconnect the inverter from the utility grid and the PV array, and reconnect it after LED turns off. If this fault is still being displayed, please contact service.
2	A faulty current sensor detected	AC current sensor detect current abnormal in the start process	Disconnect the inverter from the utility grid and the PV array, and reconnect it after LED turns off. If this fault is still being displayed, please contact service.
3	Ground fault circuit interrupter (GFCI) sensor error	GFCI sensor self-check abnormal	Disconnect the inverter from the utility grid and the PV array, and reconnect it after LED turns off. If this fault is still being displayed, please contact service.

HI PHYSIX LABORATORY INDIA PVT. LTD.

 Dr. V. A. Awjale
 (General Manager - Electronics Division)



TC-5100

IS 16221 (PART 2):2015

Clause	Requirement + Test	Result - Remark	Verdict
--------	--------------------	-----------------	---------

4	A faulty grid relay detected.	The difference between INV voltage and output voltage exceeds limit.	<ol style="list-style-type: none"> 1. Disconnect the inverter from the utility grid and the PV array, and reconnect it after LED turns off. 2. If the fault persists, measure the phase to phase voltage and phase to zero and zero to ground voltage with a multimeter to ensure that the voltage is normal and the zero to ground voltage value should not be greater than 10V. 3. Disconnect the inverter from the utility grid and the PV array, and reconnect it after LED turns off. <p>If this fault is still being displayed, please contact service.</p>
5	PV voltage too high.	When the PV voltage of any circuit is greater than 1000V, it is determined as the PV voltage is too high.	<p>Check the open-circuit voltages of the strings and make sure it is below the maximum DC input voltage of the inverter. If the input voltage lies within the permissible range while the fault occurs, please contact the service.</p>
6	Surface insulation resistance error.	In the process of power on and start-up, the insulation impedance of PV+ and PV- to ground is detected. When the detection insulation impedance is less than 200kOhm, it is judged as insulation fault.	<ol style="list-style-type: none"> 1. If it happens occasionally, it may be caused by rain or humid environment. After the fault is eliminated, the inverter can resume normal operation without other actions. 2. If there is continuous alarm, please check the PV array's insulation to ground and make sure that the insulation resistance to ground is greater than 200kΩ. Otherwise, visual inspection of all PV cables and modules. Make sure the grounding connection of the inverter is reliable. <p>If all above are normal, please contact the service.</p>
7	Ground fault circuit interrupter (GFI) exceeds the permissible range.	Residual current over the permission range.	<ol style="list-style-type: none"> 1. Make sure the grounding connection of the inverter is reliable. 2. Make a visual inspection of all PV cables and modules. <p>If this fault is still shown, contact the service.</p>
8	Inverter temperature too high.	Heat sink and internal environment temperature higher than 95 degree.	<p>Please confirm:</p> <ol style="list-style-type: none"> 1. Whether the airflow to the heat sink is obstructed. 2. Whether the installation site is in direct sunlight and ambient temperature around the inverter is too high. <p>If all above is normal, contact the service.</p>

USER MANUAL 24



TC-5100

IS 16221 (PART 2):2015

Clause	Requirement + Test	Result - Remark	Verdict
--------	--------------------	-----------------	---------

9	Utility grid disconnected	inverse detected grid voltage filed	<p>1. If it happens occasionally, it belongs to the short-time abnormality of the power grid, the inverter will return to normal operation after detecting that the power grid is normal, and there is no need to deal with it.</p> <p>2. If it cannot be recovered for a long time, please confirm:</p> <ul style="list-style-type: none"> ① Whether the AC circuit breaker is disconnected ② Whether the AC terminal or fuse is in good contact ③ Whether the power supply line is normal <p>If this fault is still being shown, contact the service.</p>
10	Grid voltage exceeds the permissible range	grid voltage exceeds the safety regulations	<p>1. If it happens occasionally, it belongs to the short-time abnormality of the power grid, the inverter will return to normal operation after detecting the normal power grid, and there is no need to deal with it.</p> <p>2. In case of frequent occurrence but automatic recovery, please confirm if the grid voltage is outside the permissible range due to local grid conditions, try to modify the values of the motor load operational limits after informing the electric utility company first.</p> <p>3. If it cannot be recovered for a long time, please confirm:</p> <ul style="list-style-type: none"> ① Whether the AC circuit breaker is disconnected ② Whether the AC terminal is in good connection ③ Whether the power supply line is normal ④ Whether the AC cable wiring (such as wire length and wire diameter) complies with the user manual guidance ⑤ Whether the safety regulation settings are normal
11	Grid frequency exceeds the permissible range	grid frequency exceeds the safety regulations	<p>1. If it happens occasionally, it belongs to the short-time abnormality of the power grid, the inverter will return to normal operation after detecting the normal power grid, and there is no need to deal with it.</p> <p>2. In case of frequent occurrence but automatic recovery, please confirm if the grid voltage is outside the permissible range due to</p>

25

USER MANUAL



TC-5100

IS 16221 (PART 2):2015

Clause	Requirement + Test	Result - Remark	Verdict
--------	--------------------	-----------------	---------

			local grid conditions, try to modify the values of the monitored operational limits after informing the electric utility company first. 3. If it cannot be recovered for a long time, please confirm: ① whether the AC circuit breaker is disconnected ② whether the AC terminal is in good connection ③ whether the power supply line is normal ④ whether the safety regulation settings are normal.
12	DC component of the electricity exceeds the permissible range	the current exceeds 1A in static state and 4A in dynamic state	Disconnect the inverter from the utility grid and the PV array, and reconnect it after LED turns off. If this fault is still being displayed, please contact the service.
13	EEPROM Error, e.g. transmission disturbance	Micro CPU read EEPROM failed	Disconnect the inverter from the utility grid and the PV array, and reconnect it after LED turns off. If this fault is still being displayed, please contact the service.
14	Internal communication fault	Master CPU communicate with slave CPU abnormal	Disconnect the inverter from the utility grid and the PV array, and reconnect it after LED turns off. If this fault is still being displayed, please contact the service.
15	Bus-voltage too high	Bus-voltage is greater than 1000V	Check the open-circuit voltages of the strings and make sure it is below the maximum DC input voltage of the inverter. If the input voltage lies within the permissible range while the fault occurs, please contact the service.
16	Bus-voltage too low	Bus-voltage is 20V lower than standard Bus-voltage	Check the open-circuit voltages of the strings and make sure it is below the maximum DC input voltage of the inverter. If the input voltage lies within the permissible range while the fault occurs, please contact the service.
17	DRM 50 Error	DRM switch 50 fault	Check the connection of DRM device. If the DRM device is connected normally while this fault occurs, please contact the service.

USER MANUAL 26



TC-5100

IS 16221 (PART 2):2015

Clause	Requirement + Test	Result - Remark	Verdict
--------	--------------------	-----------------	---------

19	EPM 50 Error	DRM switch 50 fault	Check the connection of DRM device if the DRM device is connected normally while the fault occurs, please contact the service
19	N and PE voltage exceeds permitted range		Check if the inverter is securely grounded.

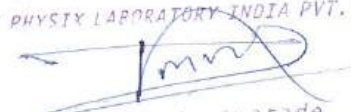
HI PHYSIX LABORATORY INDIA PVT. LTD.

 P. S. A. Awatade
 (General Manager - Electronics Division)



TC-5100

IS 16221 (PART 2):2015

Clause	Requirement + Test	Result - Remark	Verdict
--------	--------------------	-----------------	---------

11. SYSTEM MAINTENANCE

For the inverter's long-term performance, it is suggested to maintain your inverter regularly.

NOTICE:

HEAT SINK MIGHT INDUCE INJURY

When the inverter is operating, the heat sink might exceed 60°C

- Please disconnect all electrical cables and connections. Wait for the inverter to cool down completely.
- Use compressed air cleaning or a soft brush to clean the inverter heat sink.
- ALL aggressive chemicals, cleaning solvents or strong detergents are FORBIDDEN

Content	Maintenance Measures	Cycle
System Cleaning	<ul style="list-style-type: none"> • Check if the heat sink is covered and dusted • Maintenance of DC Switch can be performed at night. Turn the switch to ON and OFF positions for 4-5 times. • Use a wet cloth to clean the display. 	Annually OR Half a year
System Status	<ul style="list-style-type: none"> • Inspect the enclosure for damage/deformation • Listen for abnormal noises during operation • Check if the parameters are normal during operation 	Half a year
Commissioning	<ul style="list-style-type: none"> • Check if the cables are loose • Check if the cable insulations are damaged, especially the parts in contact with metal surfaces 	Half a year after first commissioning Annually OR Half a year
Grounding	<ul style="list-style-type: none"> • Check if the cables are securely grounded 	Half a year after first commissioning Annually OR Half a year

USER MANUAL 28

HI PHYSIX LABORATORY INDIA PVT. LTD.

(Handwritten signature)
S. Awatade
(General Manager - Electronics Division)



TC-5100

IS 16221 (PART 2):2015

Clause	Requirement + Test	Result - Remark	Verdict
--------	--------------------	-----------------	---------

12. RESTARTS

When reconnecting the inverter for electrical power supply, please follow the commissioning procedures and safety instructions as described in **Section 6** when applicable (e.g. DC Wires need to be reassembled).

Please run safety checks as described in **Section 7** before closing the DC Switch and starting up again.



[Handwritten Signature]
Awatade



TC-5100

ULR-TC510022000000496F

Page 95 of 107

Report No. HPLI/Test/2204003501

IS 16221 (PART 2):2015

Clause	Requirement + Test	Result - Remark	Verdict
--------	--------------------	-----------------	---------

Appendix B

14	TABLE: List of critical components				P
Object/part no.	Manufacturer/ trademark	Type/model	Technical data	Standard	Mark(s) of conformity ¹ .
Whole Unit					
Metal enclosure	Suzhu Gangwang Metal Technology Co., Ltd	KSY-22KW-3P	Size:416x343.8x185mm; thickness: 2,3mm; Material: aluminum.	IS 16221 (Part 2): 2015/IEC 6219- 2:2011	Tested with equipment
Heat sink	Tianjin Ruixin Technology Co., Ltd.	KSY-22KW-3P	Size:238x255x89. 5mm; thickness: 2,3mm; Material: aluminum.	IS 16221 (Part 2): 2015/IEC 6219- 2:2011	Tested with equipment
PV connector	Dongguan Vaconn Electronic Technology Co.,Ltd.	VP-D4B-PHSF4/ VP-D4B-PHSM4	1100V/30A, IP68, -40°C...85°C	IEC 62852:2014	TUV Rheinland (R 50396796)
AC output connector	DONGGUAN VACONN POWER ELECTRONIC CO.,LTD	VPAC06EW- 5P(SC)16	600Vac, 65A, -40°C~90°C, IP67	EN 61984:2009 (Harmonized with IEC 61984)	TUV Rheinland (R 50243672)
DC Switch	BEIJING EPEOPLE'S ELECTRIC PLANT CO., LTD	GHX5-32P	32A,1000V	EN 60947- 3:2009+A1+A2 (Harmonized with IEC 60947-3)	TUV Rheinland (R50439884)
DC Input Wire	3Q WIRE & CABLE CO LTD	Style 10271	105°C, 1000Vac	UL 758 (Harmonized IEC standard not available)	UL (E341104)
AC Output wire	GUANGDONG HAERKN NEW ENERGY CO LTD	Style 10269	105°C, 1000Vac	UL 758 (Harmonized IEC standard not available)	UL (E300956)
Insulation tube	SHENZHEN WOER HEAT-SHRINKABLE MATERIAL CO LTD	RSFR-H	600V, 125°C	UL 224 (Harmonized IEC standard not available)	UL (E203950)

HI PHYSIX LABORATORY INDIA PVT. LTD.

(Signature)
D. V. Avatade
(General Manager - Electronics Division)

TRF No. IS 16221 (Part 2): 2015_V1.0



TC-5100

IS 16221 (PART 2):2015

Clause	Requirement + Test	Result - Remark			Verdict
Inside DC Fan	NMB Technologies Corporation	06025SA-12R-BT	12Vdc ,0.31A	IEC 62368-1:2014	VDE (40007459)
Outside DC Fan	NMB Technologies Corporation	08025VE-12M-CTD	12Vdc ,0.30A	IEC 62368-1:2014	VDE (124972)
Boost Inductor	Qingdao Yunlu Energy Technology Co.LTD	H561-10025-00	0.96mH±10%	IS 16221 (Part 2): 2015/IEC 6219-2:2011	Tested with equipment
BOARD No. (H570-70400-02)					
PCB	JIANGSU COMBO ELECTRONIC TECHNOLOGY CO LTD	CB-M-1	V-0, 130°C	UL 796 (IEC standard not available)	UL (E307203)
Relay (RY1601,RY1602, RY1603,RY1604, RY1605,RY1606)	Xiamen Hongfa Electroacoustic Co., Ltd.	HF165F	35A,250Vac	IEC/EN 61810-1:2015	VDE (40037289)
Capacitor (C1623,C1622, C1624,)	Xiamen Faratronic Co., Ltd.	C6A	5.0µF, 350VAC, 40/85/56	IEC 61071:2007 IEC 61881-1:2010	TUV Rheinland (R 50266136)
X2 -Capacitor (C1619,C1620,C 1621)	Xiamen Faratronic Co., Ltd.	C4B	4.7µF,350Vac 40/110/56/B	EN 60384-14:2013 (Harmonized with IEC 60381-14)	ENEC certificate no.(SE/0366-6)
X2 -Capacitor (C1766,C1767,C 1768)	Xiamen Faratronic Co., Ltd.	C4B	3.3µF, 350Vac 40/110/56/B	EN 60384-14:2013 (Harmonized with IEC 60381-14)	ENEC certificate no.(SE/0366-6)
Y-Capacitor (C1407,C1609, C1607,C1610, C1775,C1776,C1774,C1769,C1773,C1772,C1771, C1770)	Xiamen Faratronic Co. Ltd.	MKP63	0.01uF, 300Vac	EN 60384-14:2013 (Harmonized with IEC 60381-14)	ENEC certificate no. (SE/0366-2C)

HI PHYSIX LABORATORY INDIA PVT. LTD.
(Signature)
Anwarade
(General Manager - Electronics Division)

TRF No. IS 16221 (Part 2): 2015_V1.0



TC-5100

ULR-TC510022000000496F

Page 97 of 107

Report No. HPLI/Test/2204003501

IS 16221 (PART 2):2015

Clause	Requirement + Test	Result - Remark			Verdict
AC Current Transducer (HCT1601, HCT1602, HCT1603)	LEM International	CASR50-NP	50A, operation temperature: -40°C...105°C	UL508 (Harmonized IEC standard not available)	UL (E189713)
Choke (CT1703)	SHENZHEN BAOYINENG ELECTRON TECHNOLOGY CO.,LTD	T50X25X20 R10K	630uH MIN	IS 16221 (Part 2): 2015/ IEC 62109-2: 2011	Tested with equipment
BOARD NO. (H570-10700-00)					
PCB	JIANGSU COMBO ELECTRONIC TECHNOLOGY CO LTD	CB-M-1	V-0, 130°C	UL 796 (IEC standard not available)	UL (E307203)
Current Transducer (HCT101, HCT102)	LEM International SA	HLSR 20-P	20A Uc= +5Vc	UL 508 (IEC standard not available)	UL (E189713)
Capacitor (C104,C116)	Xiamen Faratronic Co. Ltd.	C3D	12uF,1100Vdc 40/85/56	EN 61071:2007 (Harmonized with IEC 61071:2007))	TUV Rheinland (R 50266108)
Capacitor (C103,C115)	Xiamen Faratronic Co. Ltd.	C3D	1.0uF,1200Vdc 40/85/56	EN 61071:2007 (Harmonized with IEC 61071:2007)	TUV Rheinland (R 50266108)
Current Transformer (CT101)	SHENZHEN BAOYINENG ELECTRON TECHNOLOGY CO.,LTD	T50X25X20 R10K	630uH MIN	IS 16221 (Part 2): 2015/ IEC 62109-2: 2011	Tested with equipment
Transformer (TX404,TX402, TX406)	WUXI JINGLEI ELECTRONIC CO.LTD	H560-00009-00	1.3mH Min	IS 16221 (Part 2): 2015/ IEC 62109-2: 2011	Tested with equipment

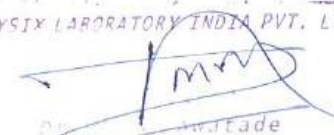
HI PHYSIX LABORATORY INDIA PVT. LTD.

 Anil K. Jaiswal
 (General Manager - Electronics Division)

TRF No. IS 16221 (Part 2): 2015_V1.0



TC-5100

ULR-TC510022000000496F

Page 98 of 107

Report No. HPLI/Test/2204003501

IS 16221 (PART 2):2015

Clause	Requirement + Test	Result - Remark	Verdict		
Bobbin	CHANG CHUN PLASTICS CO LTD	T375J	V-0, 150°C	UL 94 (Harmonized IEC standard not available)	UL(E59481)
Wire	JIANGSU DARTONG M & E CO LTD	xUEW- MW79	150°C	UL 2353 (Harmonized with IEC 60950-1)	UL(E237377)
Insulation Tape	JINGJIANG YAHUA PRESSURE SENSITIVE GLUE CO LTD	CT	130°C	UL 510A (IEC standard not available)	UL(E165111)
Barrier Tape	JINGJIANG YAHUA PRESSURE SENSITIVE GLUE CO LTD	WF-2901	130°C	UL 510A (IEC standard not available)	UL (165111)
Tube	GREAT HOLDING INDUSTRIAL CO LTD	TFT	200°C	UL 224 (IEC standard not available)	UL (156256)
Varnish	SUZHOU TAIHU ELECTRIC ADVANCED MATERIAL CO LTD	T-4260(a)	155°C	UL 1446 (IEC standard not available)	UL (228349)
Epoxy	FONG YONG CHEMICAL CO LTD	E-536/H-536	V-0, 130°C	UL 94 (Harmonized IEC standard not available)	UL(E120665)
Inductor (L503)	SHENZHEN BAOYINENG ELECTRON TECHNOLOGY	H560-00015-00	class B	IS 16221 (Part 2): 2015/ IEC 62109-2: 2011	Tested with equipment

HI PHYSIX LABORATORY INDIA PVT. LTD.

(Signature)
Awatade
(General Manager - Electronics Division)

TRF No. IS 16221 (Part 2): 2015_V1.0



TC-5100

ULR-TC510022000000496F

Page 99 of 107

Report No. HPLI/Test/2204003501

IS 16221 (PART 2):2015

Clause	Requirement + Test	Result - Remark			Verdict
BOBBIN	CHANG CHUN PLASTICS CO LTD	T375J	V-0, 150°C	UL 746B (IEC standard not available)	UL(E59481)
Wire	DONG GUAN YIDA INDUSTRIAL CO LTD	UEW/155 QA-x/155	155°C	UL 1446 (IEC standard not available)	UL(E344055)
INSULATION TAPE	JINGJIANG YAHUA PRESSURE SENSITIVE GLUE CO LTD	CT* (c)(g)	130°C	UL 510A (IEC standard not available)	UL(E165111)
BARRIER TAPE	JINGJIANG YAHUA PRESSURE SENSITIVE GLUE CO LTD	WF	130°C	UL 510A (IEC standard not available)	UL(E165111)
TUBE	GREAT HOLDING INDUSTRIAL CO LTD	TFT	200°C	UL 224 (IEC standard not available)	UL(E156256)
TRIPPLE-INSULATION Wire	ZHICHANG (GUANGZHOU) ELECTRONIC TECHNOLOGY CO., LTD.	LSTIW	130°C	UL 2353 (Harmonized with IEC 60950-1)	UL(E353227)
Epoxy	DONGGUAN EATTO ELECTRONIC MATERIAL CO LTD	3300A/B	V-0,90°C	UL 94 (Harmonized IEC standard not available)	UL(E218090)
Varnish	ZHUHAI CHANGXIAN NEW MATERIALS TECHNOLOGY CO LTD	E962	130°C	UL 1446 (IEC standard not available)	UL(E335405)

HI PHYSIX LABORATORY INDIA PVT. LTD.

(Signature)
Dr. V. A. Awatade
(General Manager - Electronics Division)

TRF No. IS 16221 (Part 2): 2015_V1.0



TC-5100

IS 16221 (PART 2):2015

Clause	Requirement + Test			Result - Remark	Verdict
Y2-Capacitor (C101, C102, C114)	Xiamen Faratronic Co. Ltd.	MKP63	0.01uF, 300Vac 40/110/56/B	EN 60384- 14:2013 (Harmonized with IEC 60384-14)	ENEC certificate no. (SE/0366-2C)
Y2-Capacitor (C128, C129, C130, C209, C210, C212)	Xiamen Faratronic Co. Ltd.	MKP63	0.01uF, 300Vac 40/110/56/B	EN 60384- 14:2013 (Harmonized with IEC 60384-14)	ENEC certificate no. (SE/0366-2C)
Boost IGBT (Q101, Q102)	INFINEON	IKQ50N120CH3	1200V, 50A -25 to 175°C	IS 16221 (Part 2): 2015/ IEC 62109-2:2011	Tested with equipment
INV IGBT (QV201, QV204, QU204, QU201, QW204, QW201)	INFINEON	IKQ50N120CH3	1200V, 50A -40 to 175°C	IS 16221 (Part 2): 2015/ IEC 62109-2:2011	Tested with equipment
Alternate	ON Semiconductor	FGY60T120SQDN/ D	1200V, 50A -55 to 175°C	IS 16221 (Part 2): 2015/ IEC 62109-2:2011	Tested with equipment
INV IGBT (QV202, QV203, QU202, QU203, QW202, QW203)	INFINEON	IKW50N65ES5	650V, 50A -40 to 175°C	IS 16221 (Part 2): 2015/ IEC 62109-2:2011	Tested with equipment
Alternate	INFINEON	IKW50N60H3	600V, 50A -40 to 175°C	IS 16221 (Part 2): 2015/ IEC 62109-2:2011	Tested with equipment
Alternate	ON Semiconductor	FGH60T65SQD- F155	650V, 60A -55 to 175°C	IS 16221 (Part 2): 2015/ IEC 62109-2:2011	Tested with equipment
DIODE (D101, D102)	INFINEON	IDWD20G120C5	1200V, 20A -55 to 175°C	IS 16221 (Part 2): 2015/ IEC 62109-2:2011	Tested with equipment

HI PHYSIX LABORATORY INDIA PVT. LTD.
(Signature)
General Manager (Electronics Division)

TRF No. IS 16221 (Part 2): 2015_V1.0



TC-5100

ULR-TC510022000000496F

Page 101 of 107

Report No. HPLI/Test/2204003501

IS 16221 (PART 2):2015

Clause	Requirement + Test	Result - Remark	Verdict		
Alternate	CREE C4D20120H	1200V, 20A -55 to 175°C	IS 16221 (Part 2): 2015/ IEC 62109-2:2011	Tested with equipment	
Relay (K701)	Xiamen Hongfa Electroacoustic Co., Ltd.	HFD3-W12-2H-3S	2A,30 Vdc 1A,277 Vac	IEC 61810-1:2015 EN 61810-1:2015	TUV Rheinland (R 50433438)

Supplementary information: ¹. Evidence provided by the manufacturer for the listed components are verified by us and the evidence are conforming to the requirement of relevant standard

TRF No. IS 16221 (Part 2): 2015_V1.0

HI PHYSIX LABORATORY INDIA PVT. LTD.
(Signature)
V. Awasthi
(General Manager - Electronics Division)



TC-5100

IS 16221 (PART 2):2015			
Clause	Requirement + Test	Result - Remark	Verdict

List of measurement units used for investigation

Sr. no.	Unit	Type	Calibration date	Expiration date	Fixtures-No.
1	Solar Array simulator	PVS1200	16/12/2021	15/12/2022	HPLI/T-E/535
2	Anti-islanding test load	PV-RLC385-200K	16/12/2021	15/12/2022	HPLI/T-E/533
3	Grid simulator Programmable AC Power source	PVS7200T	16/12/2021	15/12/2022	HPLI/T-E/532
4	Digital power harmonic Analyzer with CT	PW3337	06/01/2022 to 12/01/2022	11/01/2023	HPLI/T-E/518
5	Power quality analyzer	PQ3100	06/02/2022 to 07/02/2022	05/02/2023	HPLI/T-E/579
6	Data Logger (16 Chanel)	DL-35W	27/10/2021	26/10/2022	HPLI/T-E/336
7	H.V. Breakdown Tester-2	Digital	18/10/2021	17/10/2022	HPLI/T-E/007
8	Stop Watch	Digital	27/10/2021	26/10/2022	HPLI/T-E/023
9	Oscilloscope	TBS1102	18/01/2022	18/01/2023	HPLI/T-E/173
10	Digimatic Caliper	Digital	20/10/2021	19/10/2022	HPLI/T-E/315
11	Dust Proof Chamber (Timer)	---	19/10/2021	18/10/2022	HPLI/T-E/052
12	IP machine with Standard nozzle	---	19/10/2021	18/10/2022	HPLI/T-E/087
13	PAES Test Apparatus	Digital	29/10/2021	28/10/2022	HPLI/T-E/340
14	Impulse tester	IT16kV	08/07/2021	07/07/2022	HPLI/U2/T-E/052
15	Touch current network Figure 4 of IEC 60990: 1999 with multimeter	Analog	25/10/2021	24/10/2022	HPLI/T-E/308
16	Sonic pressure and sound level measuring instrument	SL-4001	15/07/2021	14/07/2022	HPLI/T-E/253
17	Residual current meter with Adjustable resistances	DM3058E	16/12/2021	15/12/2022	HPLI/T-E/534
18	D.C. High Voltage tester	Digital	21/10/2021	20/10/2022	HPLI/U2/TEST/151
19	Hot air oven	Digital	20/10/2021	19/10/2022	HPLI/U2/TEST/190

Supplementary information: Nil



TC-5100

IS 16221 (PART 2):2015

Clause	Requirement + Test	Result - Remark	Verdict
--------	--------------------	-----------------	---------

Appendix C

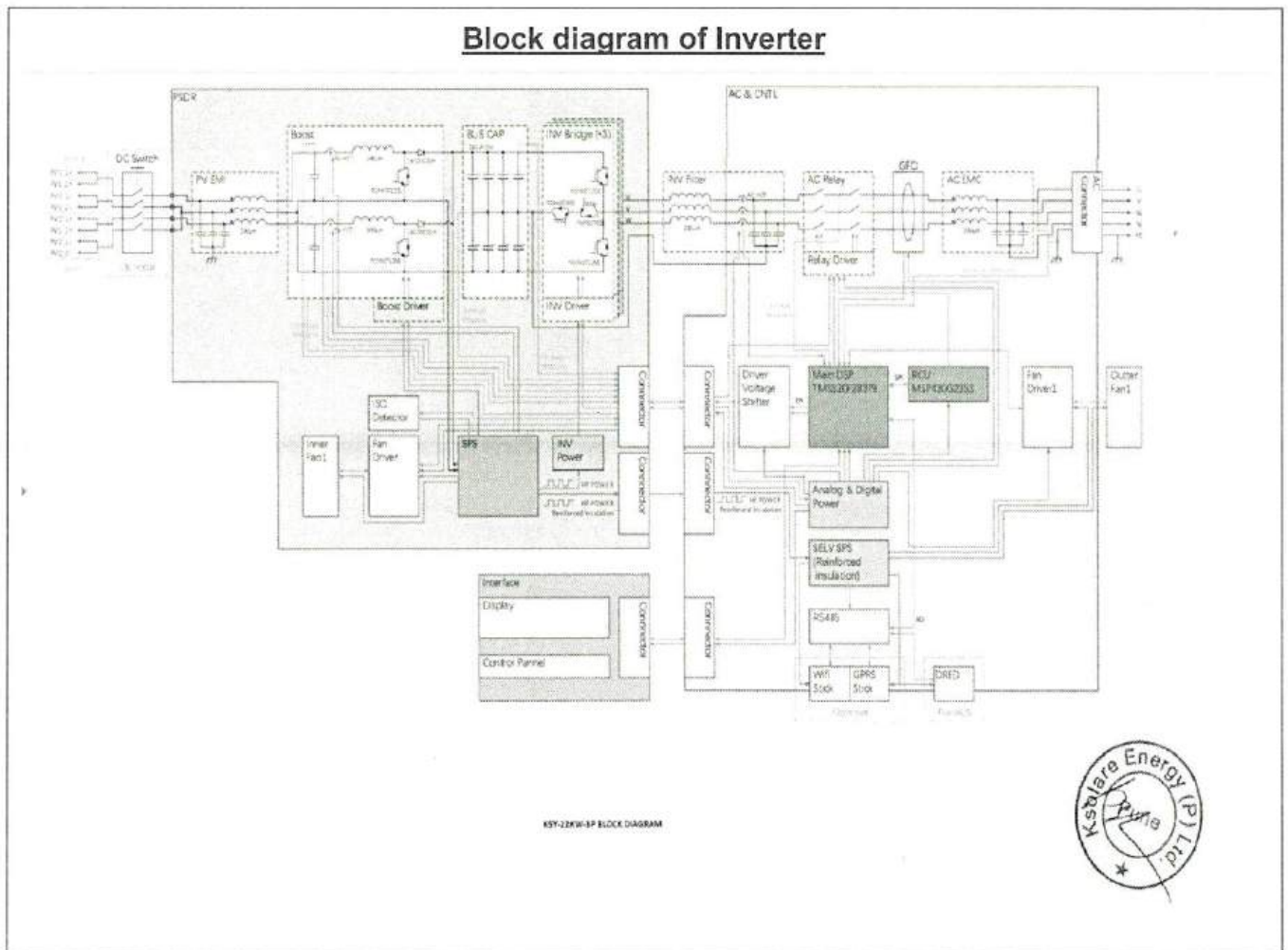

HI PHYSIX LABORATORY INDIA PVT. LTD.

(Handwritten signature)
Awatade
(General Manager - Electronics Division)



TC-5100

IS 16221 (PART 2):2015

Clause	Requirement + Test	Result - Remark	Verdict
--------	--------------------	-----------------	---------

Appendix D
PHOTO DOCUMENTS

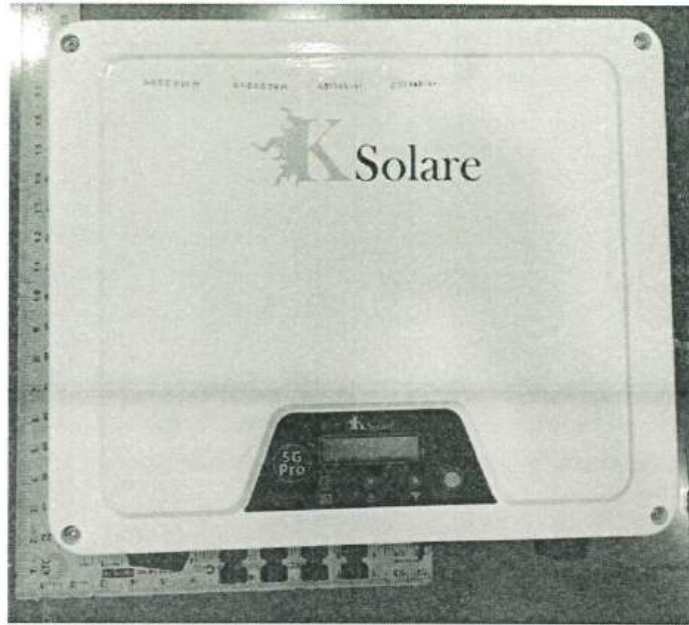

FRONT VIEW

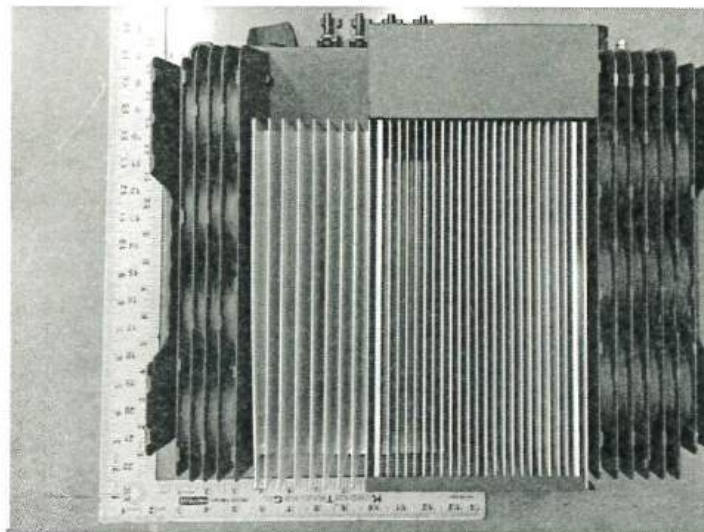

BACK VIEW

HI PHYSIX LABORATORY INDIA PVT. LTD.

[Signature]
Anujade
(General Manager - Electronics Division)

TRF No. IS 16221 (Part 2): 2015_V1.0



TC-5100

IS 16221 (PART 2):2015

Clause	Requirement + Test	Result - Remark	Verdict
--------	--------------------	-----------------	---------

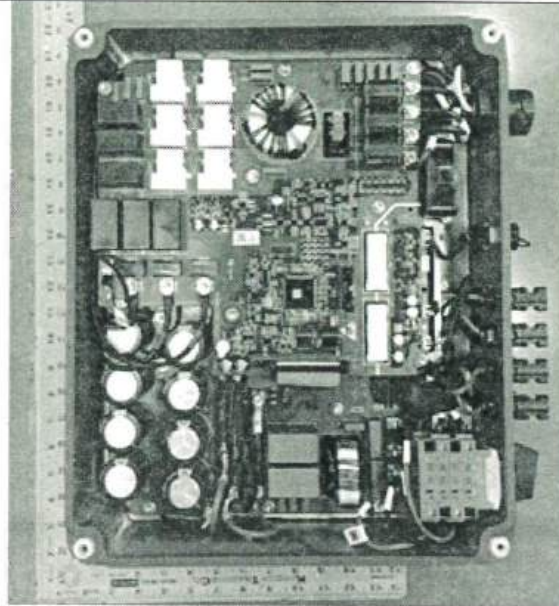

INTERNAL VIEW

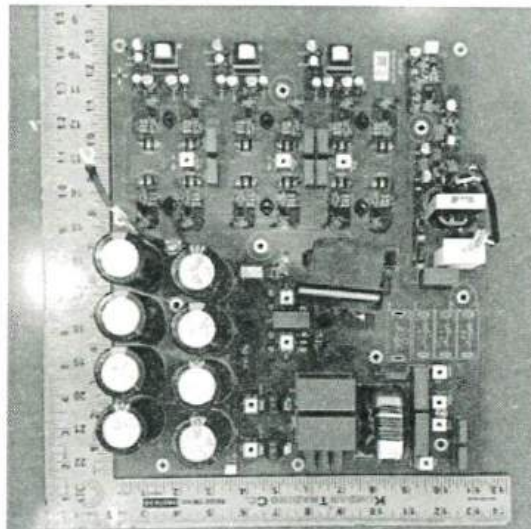

PCB BOARD COMPONENT SIDE VIEW

HI PHYSIX LABORATORY INDIA PVT. LTD.

(Handwritten signature)
A. Awatade
(General Manager - Electronics Division)

TRF No. IS 16221 (Part 2): 2015_V1.0



TC-5100

ULR-TC510022000000496F

Page 106 of 107

Report No. HPLI/Test/2204003501

IS 16221 (PART 2):2015

Clause	Requirement + Test	Result - Remark	Verdict
--------	--------------------	-----------------	---------

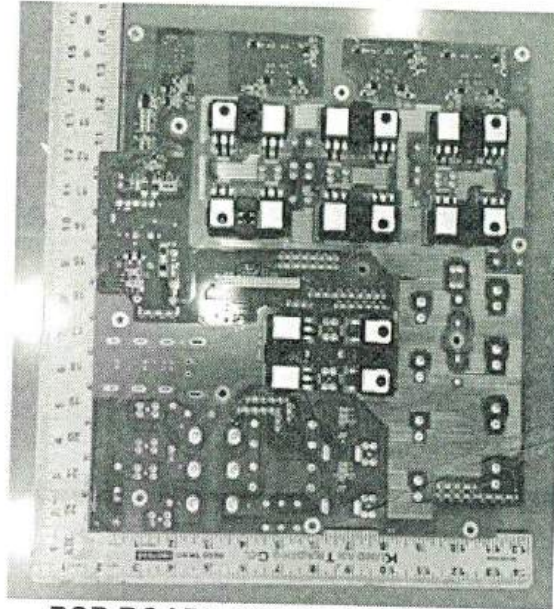

PCB BOARD SOLDER SIDE VIEW

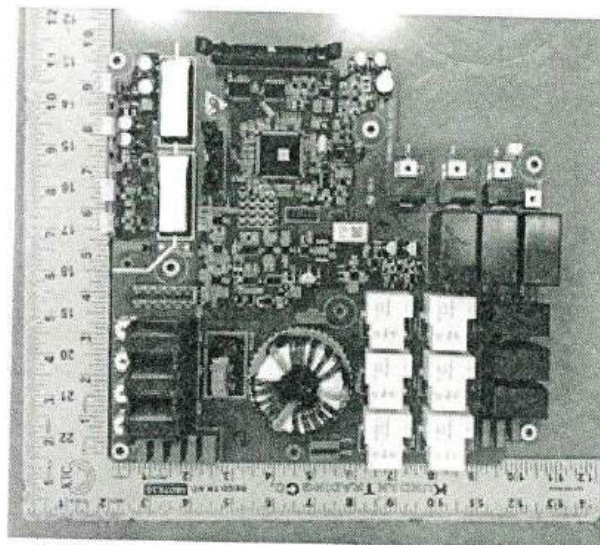

PCB BOARD COMPONENT SIDE VIEW

HI PHYSIX LABORATORY INDIA PVT. LTD.

[Signature]
Dr. S. S. Sawade
(General Manager - Electronics Division)

TRF No. IS 16221 (Part 2): 2015_V1.0



TC-5100

IS 16221 (PART 2):2015

Clause	Requirement + Test	Result - Remark	Verdict
--------	--------------------	-----------------	---------

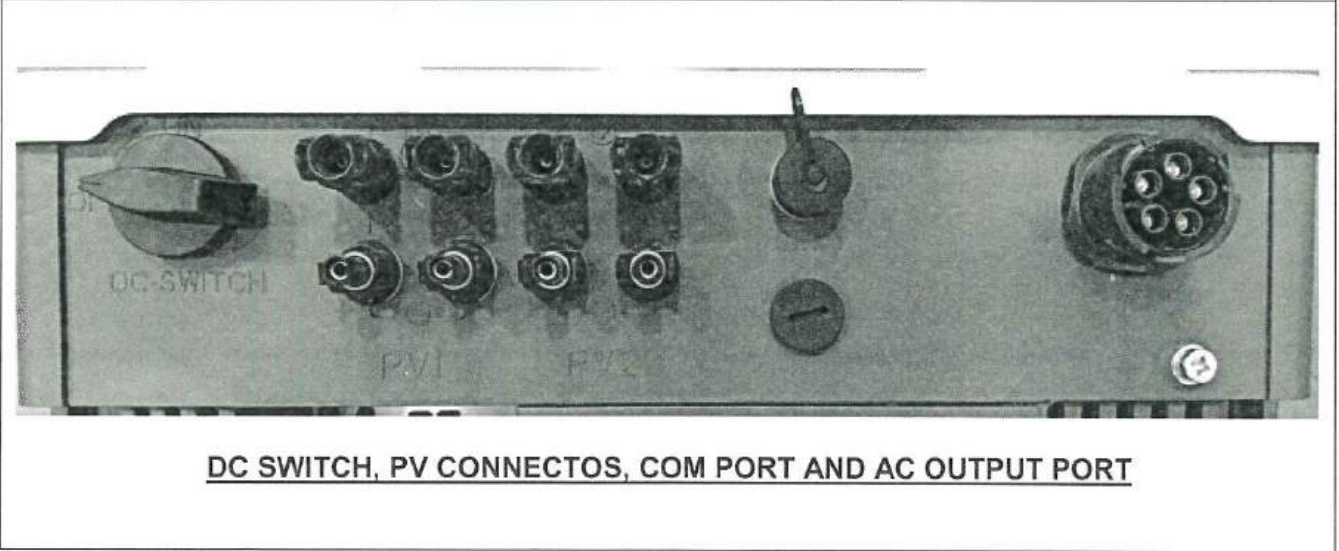
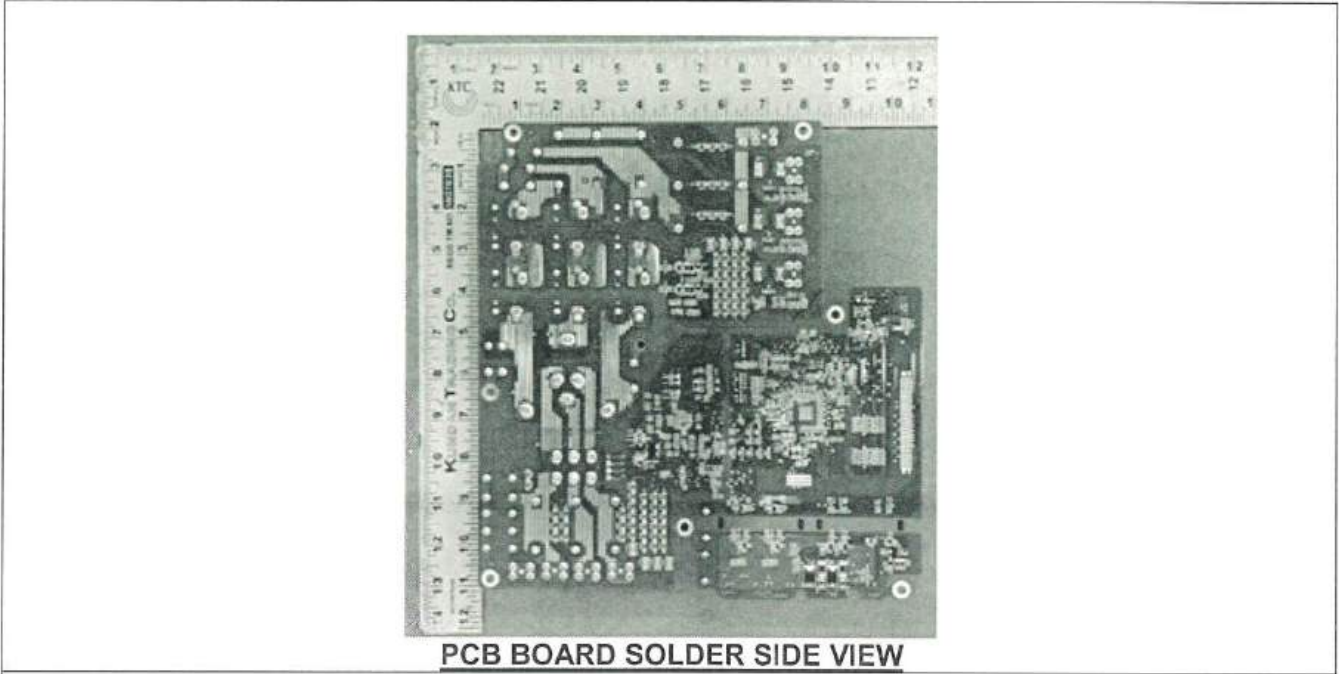

HI PHYSIX LABORATORY INDIA PVT. LTD.
(Signature)
 (General Manager - Electronics Division)

--- End of Test Report ---